



Converged Personal Network Service Architecture

Candidate Version 1.1 – 29 May 2012

Open Mobile Alliance
OMA-AD-CPNS-V1_1-20120529-C

Use of this document is subject to all of the terms and conditions of the Use Agreement located at <http://www.openmobilealliance.org/UseAgreement.html>.

Unless this document is clearly designated as an approved specification, this document is a work in process, is not an approved Open Mobile Alliance™ specification, and is subject to revision or removal without notice.

You may use this document or any part of the document for internal or educational purposes only, provided you do not modify, edit or take out of context the information in this document in any manner. Information contained in this document may be used, at your sole risk, for any purposes. You may not use this document in any other manner without the prior written permission of the Open Mobile Alliance. The Open Mobile Alliance authorizes you to copy this document, provided that you retain all copyright and other proprietary notices contained in the original materials on any copies of the materials and that you comply strictly with these terms. This copyright permission does not constitute an endorsement of the products or services. The Open Mobile Alliance assumes no responsibility for errors or omissions in this document.

Each Open Mobile Alliance member has agreed to use reasonable endeavors to inform the Open Mobile Alliance in a timely manner of Essential IPR as it becomes aware that the Essential IPR is related to the prepared or published specification. However, the members do not have an obligation to conduct IPR searches. The declared Essential IPR is publicly available to members and non-members of the Open Mobile Alliance and may be found on the “OMA IPR Declarations” list at <http://www.openmobilealliance.org/ipr.html>. The Open Mobile Alliance has not conducted an independent IPR review of this document and the information contained herein, and makes no representations or warranties regarding third party IPR, including without limitation patents, copyrights or trade secret rights. This document may contain inventions for which you must obtain licenses from third parties before making, using or selling the inventions. Defined terms above are set forth in the schedule to the Open Mobile Alliance Application Form.

NO REPRESENTATIONS OR WARRANTIES (WHETHER EXPRESS OR IMPLIED) ARE MADE BY THE OPEN MOBILE ALLIANCE OR ANY OPEN MOBILE ALLIANCE MEMBER OR ITS AFFILIATES REGARDING ANY OF THE IPR'S REPRESENTED ON THE “OMA IPR DECLARATIONS” LIST, INCLUDING, BUT NOT LIMITED TO THE ACCURACY, COMPLETENESS, VALIDITY OR RELEVANCE OF THE INFORMATION OR WHETHER OR NOT SUCH RIGHTS ARE ESSENTIAL OR NON-ESSENTIAL.

THE OPEN MOBILE ALLIANCE IS NOT LIABLE FOR AND HEREBY DISCLAIMS ANY DIRECT, INDIRECT, PUNITIVE, SPECIAL, INCIDENTAL, CONSEQUENTIAL, OR EXEMPLARY DAMAGES ARISING OUT OF OR IN CONNECTION WITH THE USE OF DOCUMENTS AND THE INFORMATION CONTAINED IN THE DOCUMENTS.

© 2012 Open Mobile Alliance Ltd. All Rights Reserved.

Used with the permission of the Open Mobile Alliance Ltd. under the terms set forth above.

Contents

1. SCOPE (INFORMATIVE)	5
2. REFERENCES	6
2.1 NORMATIVE REFERENCES	6
2.2 INFORMATIVE REFERENCES	6
3. TERMINOLOGY AND CONVENTIONS	8
3.1 CONVENTIONS	8
3.2 DEFINITIONS	8
3.3 ABBREVIATIONS	9
4. INTRODUCTION (INFORMATIVE)	10
4.1 VERSION 1.0	10
4.2 VERSION 1.1	10
5. ARCHITECTURAL MODEL	11
5.1 DEPENDENCIES	11
5.1.1 Dependency on Device Management Enabler	11
5.1.2 Dependency on DPE	11
5.1.3 Dependency on DRM	11
5.2 ARCHITECTURAL DIAGRAM	11
5.2.1 Architecture principle	12
5.3 FUNCTIONAL COMPONENTS AND INTERFACES DEFINITION	13
5.3.1 Functional Components	13
5.3.2 Functional Interfaces	14
5.4 SECURITY CONSIDERATIONS	16
5.5 CHARGING CONSIDERATIONS	17
5.5.1 Definition/role	17
5.5.2 Description	17
5.6 FUNCTIONAL MODULES	17
5.6.1 Device Capabilities	17
5.6.2 Status Management	18
5.6.3 Usage Statistics Collection and Reporting	18
5.6.4 Service Publication & Discovery	19
5.6.5 CPNS Entity Discovery and PN Registration	19
5.6.6 Security	19
5.6.7 Service/Content Delivery	20
5.6.8 Service Group Management	20
5.6.9 PN Management	21
5.6.10 Non-CPNS Proxy	22
APPENDIX A. CHANGE HISTORY (INFORMATIVE)	24
A.1 APPROVED VERSION HISTORY	24
A.2 DRAFT/CANDIDATE VERSION 1.1 HISTORY	24
APPENDIX B. CPNS LOGICAL ENTITIES AND PHYSICAL ENTITIES (INFORMATIVE)	25
B.1 TERMINOLOGY	25
B.2 CLIENT-SERVER DEPLOYMENT EXAMPLES	25
B.2.1 Basic Client-Server Deployment	25
B.2.2 Client-Server Deployment with Combined PNE & PN GW	26
B.2.3 Client-Server Deployment using Non-CPNS gateway (e.g. WiFi AP)	27
B.3 PEER-TO-PEER DEPLOYMENT EXAMPLE (DEFERRED FOR FUTURE RELEASE)	28
B.3.1 Peer-to-Peer Deployment with Dedicated Authentication/Authorisation Server	28
APPENDIX C. FUNCTIONAL DIAGRAM (INFORMATIVE)	30
APPENDIX D. FEASIBILITY STUDY OF SECURITY OF CPNS INTERFACES WHEN UTILIZING UNDERLYING NETWORK SECURITY MECHANISMS (INFORMATIVE)	31

D.1 SYSTEM ASSUMPTION31

D.2 SECURITY OF CPNS INTERFACES32

 D.2.1 CPNS-1, 632

 D.2.2 CPNS-2, 3 and 732

 D.2.2.1 Using IMS signaling channel.....32

 D.2.2.2 Using IMS media channel.....33

 D.2.3 CPNS-433

APPENDIX E. SERVICE PUBLICATION & DISCOVERY OVERVIEW (INFORMATIVE)34

E.1 INTRODUCTION.....34

E.2 DESCRIPTION.....34

E.3 DHT AND OVERLAY ROUTING34

APPENDIX F. ZONE BASED SERVICE (INFORMATIVE).....35

F.1 ZONE.....35

F.2 PUSH SERVICE USING THE ZONE PN GW35

APPENDIX G. TYPICAL FLOW (INFORMATIVE).....36

G.1 CPNS TYPICAL FLOW36

Figures

Figure 1: CPNS Architecture Diagram.....12

Figure 2: CPNS Logical Entities and Physical Entities25

Figure 3: Basic Client-Server Deployment26

Figure 4: Client-Server Deployment with Combined PNE & PN GW27

Figure 5: Client-Server Deployment using non-CPNS Gateway (e.g. Legacy WiFi Access Point).....28

Figure 6: Peer-to-Peer Deployment with Dedicated Authentication/Authorisation Server29

Figure 7: Functional diagram.....30

Figure 8: System assumption32

Figure 9: High level architecture of Service Publication and Discovery functionality and operations.....34

Figure 10: Example 8-node DHT and related overlay routing for Service Publication or Discovery34

Figure 11: CPNS typical flow.....36

1. Scope

(Informative)

The scope of the CPNS (Converged Personal Network Service) architecture document is to define the architecture for the CPNS v1.1 Enabler. This document provides the functional capabilities needed to support the Enabler as described in CPNS requirements document [CPNS-RD].

2. References

2.1 Normative References

- [CHRG-AD] “Charging Architecture”, Open Mobile Alliance™. OMA-AD-Charging-V1_1, URL: <http://www.openmobilealliance.org/>
- [CPNS-RD] “Converged Personal Network Service Requirements”, Open Mobile Alliance™, OMA-RD-CPNS-V1_1, URL: <http://www.openmobilealliance.org/>
- [DM-AD] “Device Management Architecture”, Open Mobile Alliance™, OMA-AD-DM-V1_3, URL: <http://www.openmobilealliance.org/>
- [PRS-IMPS-AD] “Presence IMPS Architecture v1.3”, Open Mobile Alliance™, OMA-AD-IMPS-V1_3, URL: <http://www.openmobilealliance.org/>
- [PRS-SIMPLE-AD] “Presence SIMPLE Specification”, Open Mobile Alliance™, OMA-AD-Presence_SIMPLE-V1_0, URL: <http://www.openmobilealliance.org/>
- [RFC2119] “Key words for use in RFCs to Indicate Requirement Levels”, S. Bradner, March 1997, URL: <http://www.ietf.org/rfc/rfc2119.txt>
- [SEC_CF AD] “Security Common Functions Architecture”, Open Mobile Alliance™, OMA-AD-SEC_CF-V1_1, URL: <http://www.openmobilealliance.org/>

2.2 Informative References

- [3GPP TS 33.203] “3G security; Access security for IP-based services”
E.g. 3GPP TS 33.203 (Release 9)
<http://www.3gpp.org/ftp/Specs/html-info/33203.htm>
- [3GPP TS 22.127] “Service requirement for the Open Services Access (OSA); Stage 1”
E.g. 3GPP TS 22.127 (Release 8)
<http://www.3gpp.org/ftp/Specs/html-info/22127.htm>
- [3GPP TS23.198] “Open Service Access (OSA); Stage 2”
E.g. 3GPP TS 23.198 (Release 8)
<http://www.3gpp.org/ftp/Specs/html-info/23198.htm>
- [3GPP TR 33.828] “IMS media plane security”
E.g. 3GPP TR 33.828 (Release 8)
<http://www.3gpp.org/ftp/Specs/html-info/33828.htm>
- [Bluetooth Security White Paper] “Bluetooth Security White Paper”
Bluetooth SIG Security Expert Group,
http://grouper.ieee.org/groups/1451/5/Comparison_of_PHY/Bluetooth_24Security_Paper.pdf
- [DLNA] <http://www.dlna.org/home>
- [IEEE802.11i] “IEEE Standard 802.11i-2004: Wireless Medium Access Control(MAC) and Physical Layer(PHY) Specifications Amendment 6: Medium Access Control(MAC) Security Enhancements”
- [OMA-AD-DPE] “Device Profile Evolution Architecture”, Open Mobile Alliance™, OMA-AD-DPE-V1_0, URL: <http://www.openmobilealliance.org/>
- [OMADICT] “Dictionary for OMA Specifications”, Version 2.8., Open Mobile Alliance™, OMA-ORG-Dictionary-V2.8, URL: <http://www.openmobilealliance.org/>
- [OMA-DRM-AD] “Digital Rights Management (DRM) Architecture v2.1”, Open Mobile Alliance™, OMA-AD-DRM-V2_1, URL: <http://www.openmobilealliance.org/>

- [P2PSIP Internet-Draft] “REsource LOcation And Discovery (RELOAD) Base Protocol”, C. Jennings, B. Lowecamp, E. Rescorla, S. Baset, H. Schulzrinne, Nov 9, 2009,
URL: <http://www.ietf.org/id/draft-ietf-p2psip-base-06.txt>
- [UPnP Forum] <http://www.upnp.org>

3. Terminology and Conventions

3.1 Conventions

The key words “MUST”, “MUST NOT”, “REQUIRED”, “SHALL”, “SHALL NOT”, “SHOULD”, “SHOULD NOT”, “RECOMMENDED”, “MAY”, and “OPTIONAL” in this document are to be interpreted as described in [RFC2119].

All sections are normative, unless they are explicitly indicated to be informative.

3.2 Definitions

Adminnee	A PNE or PN GW whose information in PN Inventory can be changed initiated by PN Admin in the same PN.
CPNS Server	See [CPNS-RD]
CPNS Functionality	Functionality (e.g. CPNS Entity Discovery, PN Management) performed by CPNS Enabler to support the CPNS Service(s). Some of the CPNS functionalities can be implemented on the Non-CPNS Device(s).
Entity-User Key (EUKey)	A security key assigned to each PNE(s) and PN GW(s) for ensuring security of communication through CPNS interfaces
External Entity	See [CPNS-RD]
Group Key	A security key which all member entities in the same Service Group share and is used for secure communication in the Service Group
Keyword	A term that captures the essence of an application or content service accessible in CPNS, and is intended for use in Service Discovery to search for the corresponding service description. Keywords maybe stored in a centralized or distributed fashion in CPNS.
Metadata Directory	In the context of Service Publication and Discovery, a logical repository of service metadata comprising keywords and/or service description documents. Those metadata are published on the Metadata Directory by the Service Offerer, and discovered by the Service Consumer. A Metadata Directory may be stored centrally, or in a distributed manner, on the CPNS Server(s).
Personal Network (PN)	See [CPNS-RD]
Personal Network Element (PNE)	See [CPNS-RD]
Personal Network Gateway (PN GW)	See [CPNS-RD]
PN Inventory	See [CPNS-RD]
Service Consumer	A PNE that consumes service(s) provided by Service Offerer(s), upon performing Service Discovery.
Service Description	A document that contains service metadata, and is specified using a description language.
Service Group (SG)	See [CPNS-RD]
Service Offerer	A PNE or external Application/Content Server that offers a service for consumption by other PNEs acting as Service Consumers, and which publishes metadata about that service on a Metadata Directory.

3.3 Abbreviations

3GPP	3rd Generation Partnership Project
DLNA	Digital Living Network Alliance
DRM	Digital Rights Management
DPE	Device Profile Evolution
PNE	Personal Network Element
PN GW	Personal Network Gateway
OMA	Open Mobile Alliance
SSL	Secure Socket Layer
TLS	Transport Layer Security
UICC	Universal Integrated Circuit Card
UPnP	Universal Plug and Play

4. Introduction (Informative)

This Architecture Document defines the architecture of CPNS (Converged Personal Network Service) Enabler based on the CPNS requirements defined in [CPNS-RD].

This Architecture Document defines the functional interfaces between the CPNS entities themselves and between CPNS entities and other External entities.

This document also describes and defines the following functions and capabilities:

- Functions of CPNS Server
- Functions of PN GWs
- Functions of PNEs
- Interactivity between services and entities in the Personal Network and WAN/Cellular networks
- Content and Service delivery
- Service Discovery and Publication
- CPNS entity Discovery and PN registration
- Usage Statistics collection and reporting (e.g., for Charging purpose)
- Device capabilities of CPNS entities
- PN Management
- Security-related function

4.1 Version 1.0

The Architecture Document of CPNS Enabler 1.0 addresses the requirements targeted for this release that are solved by architecture design.

However, this release of the AD does not address the requirements that were deferred for future releases, such as requirements on peer-to-peer implementation, the specific case on charging third parties for delivering the information to them etc.

4.2 Version 1.1

The Architecture Document of CPNS Enabler 1.1 addresses the requirements targeted for this release that are solved by architecture design.

However, this release of the AD does not address the requirements that were deferred for future releases.

5. Architectural Model

The CPNS 1.1 architecture model is based on the requirements defined in [CPNS-RD].

5.1 Dependencies

The CPNS Enabler will be dependent on the following:

5.1.1 Dependency on Device Management Enabler

NOTE: This dependency with OMA DM is optional.

CPNS entities can interact with DM Enabler for the purpose of managing CPNS Entities, e.g. firmware update, software update, device capability configuration on CPNS Entities and so on. In order to achieve this, the DM Client is required to be deployed on CPNS Entities. For those CPNS entities which have DM clients DM management can be initiated either by DM client or DM Server.

In this case, CPNS entities SHALL comply with the functionalities and interfaces as described in [DM-AD].

5.1.2 Dependency on DPE

The CPNS Enabler is dependent on the OMA DPE Enabler. This dependency is optional.

CPNS entities can interact with DPE Enabler to provide/obtain device capabilities.

CPNS entities (e.g. PNE, PN GW) can act as DPE clients to notify the DPE Server on device capabilities of PNEs and PN GWs respectively. Thus, entities, e.g. CPNS Server that would be interested in CPNS device capabilities could subscribe to the DPE Server and would be notified every time there would be a device capability change.

In this case, CPNS entities will comply with functionalities and interfaces as described in [OMA-AD-DPE]

5.1.3 Dependency on DRM

The CPNS Enabler is dependent on the OMA DRM Enabler. This dependency is optional.

CPNS entities can interact with DRM Enabler to protect CPNS content.

When CPNS content is required to be protected, DRM service is invoked through the CPNS server or through external entities, e.g. Content server.

In this case, CPNS entities will comply with functionalities and interfaces as described in [OMA-DRM-AD].

5.2 Architectural Diagram

Figure 1 shows the architectural diagram of OMA CPNS v1.1.

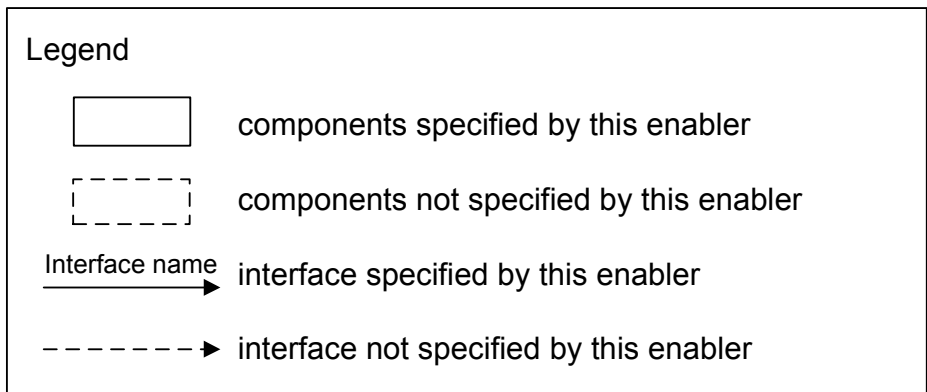
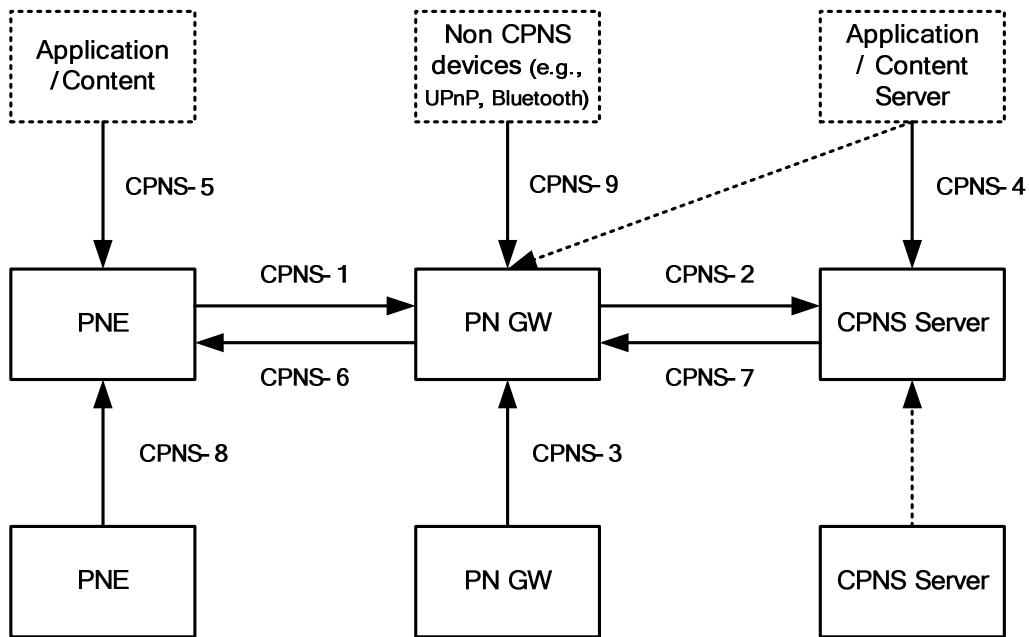

Figure 1: CPNS Architecture Diagram

5.2.1 Architecture principle

CPNS architecture consists of logical entities (i.e., PNE, PN GW, and CPNS Server). From the architectural perspective, the physical deployments are not restricted as far as capability of physical devices allow.

CPNS Enabler is agnostic to underlying network protocols.

5.3 Functional Components and Interfaces definition

5.3.1 Functional Components

This section describes the OMA CPNS v1.1 functional components.

NOTE: Please refer the section 5.5. for the details of each functions mentioned below.

5.3.1.1 CPNS Server

The CPNS Server is a CPNS Enabler component that resides in the core network performs the following functions:

- Device Capabilities
- Usage Statistics Collection and Reporting
- Service Publication & Discovery
- CPNS Entity Discovery and PN Registration
- Service and Content Delivery
- PN Management
- SG Management
- Security-related functions
- Status Management
- Charging Management

5.3.1.2 PN GW

The PN GW is a CPNS Enabler component that performs the following functions:

- Device Capabilities
- Status Management
- Usage Statistics Collection and Reporting
- Service Publication & Discovery
- CPNS Entity Discovery and PN Registration
- Non-CPNS Proxy
- Service and Content Delivery
- PN Management
- SG Management
- Security-related functions

5.3.1.3 PNE

The PNE is a CPNS Enabler component that resides on the personal network and performs the following functions:

- Device Capabilities

- Status Management
- Usage Statistics Collection and Reporting
- Service Publication & Discovery
- CPNS Entity Discovery and PN Registration
- Service and Content Delivery
- PN Management
- SG Management
- Security-related functions

5.3.2 Functional Interfaces

This section describes the OMA CPNS v1.1 functional interfaces.

5.3.2.1 CPNS-1

This interface exposed by the PN GW supports the following functions.

- Device Capabilities
- Status Management
- Service Publication and Discovery
- Usage Statistics Collection and Reporting
- CPNS Entity Discovery and PN Registration
- Service / Content Delivery
- PN Management
- SG Management
- Security

5.3.2.2 CPNS-2

This interface exposed by CPNS Server supports the following functions.

- Device Capabilities
- Status Management
- Service Publication and Discovery
- Usage Statistics Collection and Reporting
- CPNS Entity Discovery and PN Registration
- Service / Content Delivery
- PN Management
- SG Management
- Security
- Interaction with M2M

5.3.2.3 CPNS-3

This interface exposed by PN GW supports the following functions.

- CPNS Entity Discovery
- PN Management
- Service / Content Delivery
- Service Group Management
- Security
- PN GW Switching

5.3.2.4 CPNS-4

This interface exposed by CPNS Server supports the following functions.

- Device Capabilities
- Usage Statistics Collection and Reporting
- Service Publication and Discovery
- Charging Function
- Service / Content Delivery
- Status Management

5.3.2.5 CPNS-5

This interface exposed by PNE supports the following functions.

- Service Publication and Discovery
- Service / Content Delivery
- Device Capabilities
- Status Management
- Usage Statistics Collection and Reporting
- PN Management
- SG Management

5.3.2.6 CPNS-6

This interface exposed by PNE supports the following functions.

- Device CapabilitiesStatus Management
- Service Publication and Discovery
- Usage Statistics Collection and Reporting
- CPNS Entity Discovery and PN Registration

- Service / Content Delivery
- PN Management
- SG Management
- Security

5.3.2.7 CPNS-7

This interface exposed by PN GW supports the following functions.

- Device Capabilities
- Status Management
- Service Publication and Discovery
- Usage Statistics Collection and Reporting
- CPNS Entity Discovery and PN Registration
- Service / Content Delivery
- PN Management
- SG Management
- Security
- Interaction with M2M

5.3.2.8 CPNS-8

This interface exposed by PNE supports the following functions.

- CPNS Entity Discovery and PN Registration
- PN Management

5.3.2.9 CPNS-9

This interface exposed by PN GW supports the following function.

- Non-CPNS proxy

5.4 Security Considerations

The Converged Personal Network Service Enabler 1.1 provides the means to ensure security in CPNS including authentication, authorization, data integrity and data confidentiality.

If security mechanism is provided by the underlying network infrastructure (e.g., a cellular system) and its security level of the underlying network infrastructure is sufficient, the security function can utilize the security mechanism from the infrastructure. Otherwise, the security function utilizes CPNS Enabler's own security mechanism for the CPNS Service.

The CPNS Enabler 1.1 supports:

- Authentication/authorization of CPNS Users/CPNS Entities by Entity User Key

- Protection of data integrity and confidentiality
- Security-key management (i.e. Entity User Key management, Group Key management and simplified Group Key management)
- Secure content/service sharing inside Service Group by Group Key

As for the first two bullets, there is a suitable mechanism specified in OMA SEC_CF [SEC_CF AD]. In addition, OMA SEC_CF can be a solution for the third bullet when security-key is assigned to PN GW with pre-configured credential (e.g., UICC).

The security function is described in 5.5.7.2.

5.5 Charging Considerations

The CPNS service must generate information that can be processed for charging purposes.

The charging of CPNS service may be realized by the interaction with the OMA Charging Enabler [CHRG-AD].

5.5.1 Definition/role

This function facilitates offline and online charging for the CPNS service and specifies charging for the periodic delivery of personalised or customized content. The interface between the CPNS server and the OMA Charging Enabler is utilized for this charging function.

5.5.2 Description

The CPNS server generates charging information, for example, according to the user charging information that it obtains from the usage statistic collections & reporting function.

5.6 Functional Modules

5.6.1 Device Capabilities

5.6.1.1 Definition/role

This function is used for delivering and managing the information of CPNS device capabilities, e.g. hardware and software characteristics of each device in the PN.

5.6.1.2 Description

This function permits the collection and delivery of information about the static or rarely changed parameters of the device as shown below.

- Device type, e.g. 3G handset, MP3 player, Settop Box...
- Hardware characteristics of a device, e.g. the size of the screen, the size of the battery, the type of μ processor, the size of the memory, the type of chipset (main chipset, accelerator chipset, network chipset...)
- Software characteristics of a device, e.g. Installed applications, the version of the applications, the drivers for the hardware components, the versions of the drivers...

This function also permits the collection and delivery of information about dynamic parameters of the device as shown below.

- Current networks that the device connects to, e.g. UMTS network, CDMA, GSM, WIFI, Bluetooth, NFC...
- Current hardware status, e.g. currently available memory, current estimated remaining battery time, etc.

- Current software status, e.g. currently running applications, currently active drivers, etc.

In addition, this function collects, updates and manages the device capabilities in the way suitable for the CPNS service

OMA DPE Enabler facilitates the delivery of device capabilities, both static and dynamic device information to the CPNS server.

CPNS Enabler when appropriate may use DPE Enabler to make available the static and dynamic device information. If and when implemented OMA DPE Enabler can interact with the CPNS Enabler via the interfaces defined by the OMA DPE Enabler.

5.6.2 Status Management

5.6.2.1 Definition/role

This function provides a means for CPNS entities to publish, collect, subscribe to and notify the status of the CPNS entities.

5.6.2.2 Description

This function allows following status management functions.

- Status information report
 - In response to status information retrieval request, status information can be reported to requester.
 - Under certain circumstances triggered by a specific event (threshold hit, etc.), status information can be reported to target CPNS entity.
 - In occurrence of the event, status information is reported to the CPNS entity who requests the policy based status information report

This function provides information about:

- Status of PNE and PN GW(e.g. Online, Offline, Busy, etc)

5.6.3 Usage Statistics Collection and Reporting

5.6.3.1 Definition/role

This function is used to collect, summarise, and report;

- The service usage in the CPNS entity
- The device capabilities applied when the services are consumed.

5.6.3.2 Description

This function performs the following:

- The collection of all the information from the devices about the service usage and the device capabilities and status during the service usage
- Applying user preferences for usage statistics reporting of each service consumption (e.g. IPTV viewing is not allowed to be reported, but game play is)
- Reporting to the CPNS server(s) and external entities according to the user preferences as required.

5.6.4 Service Publication & Discovery

5.6.4.1 Definition/role

The Service publication and Discovery function provides the means by which service description is published by external entities and PNEs. The service description will be discovered by PNEs with the help of CPNS server.

5.6.4.2 Description

This function performs the following:

- Publish service description
- Discover and retrieve service description
- Deliver and receive the service description to/from the relevant entity
- Advertise service description
- Store service description in the CPNS Server offered by PNEs and/or External entities

The service descriptions of service offered by PNE or external entities (e.g., an application/content server owned by the service provider or a 3rd party provider) mainly contain information such as;

- what services are available to CPNS user and entity
- source of the service (i.e., CPNS entity identification, service identification, service requirement or capability of device hosting the service)

5.6.5 CPNS Entity Discovery and PN Registration

5.6.5.1 Definition/Role

This function enables discovery of the current operational CPNS Mode (PNE or PN GW) in a device and registration of the Personal Network for CPNS Services.

5.6.5.2 Description

This function facilitates discovery of CPNS entities by other CPNS entities and enables PN to be registered to CPNS Server. With the Entity Discovery function, a CPNS entity knows the Mode of other CPNS entities.

NOTE: In the case of Entity Discovery, CPNS Server is not included in the CPNS entities.

The PN GW when used for Zone Based Service performs the periodic searching for discovering PNE(s)

This function facilitates registration of information of PNE(s) and PN GW in PN Inventory stored in CPNS Server.

5.6.6 Security

5.6.6.1 Definition/role

The function provides the means to ensure security in CPNS such as authentication, authorization, data integrity and data confidentiality. If security mechanism is provided by underlying network infrastructure (e.g., cellular system) and its security level is sufficient, the function can utilize security mechanism provided by underlying network infrastructure.

5.6.6.2 Description

The function in each CPNS entity performs the following security operations. Depending on security mechanisms provided by underlying network, part of the following operations can be achieved by underlying network.

- Each CPNS entity authenticates and authorizes CPNS entity connecting through CPNS interface.
- Each CPNS entity ensures data authenticity, integrity and confidentiality of the communication through the interface. This can be done by establishing secure session (e.g. SSL/TLS session) between CPNS entities.
- CPNS Server or PN GW provisions an Entity-User Key in CPNS entity. For secure key provisioning, key provision signalling is intermediated by PN GW connected to secure underlying network.
- CPNS Server or PN GW creates, deletes and updates a Group Key when Service Group is created, deleted and its membership is updated, respectively. It also distributes the Group Key to group members by either of push or pull based method in a secure manner.

5.6.7 Service/Content Delivery

5.6.7.1 Definition/role

The Service/Content Delivery function facilitates the delivery of service/content to/from the CPNS and External entities, Between the PNEs and PN GWs:

- Between PN GWs and CPNS server
- Between CPNS Server and External entities
- Between PN GW and External entities

Service/Content Delivery function also facilitates the content forwarding from one serviced PNE to another PNE

5.6.7.2 Description

This Function performs the following:

- Invoking Services based on device capability
- Control of Service (e.g. start, stop)
- Managing the transmission of content
- Two Service/Content delivery modes: Push/ Pull
- Supporting single/ multiple services
- Aggregation and distribution for multiple PNEs,
 - Aggregation of common and specific data for multiple PNEs
 - Distribution of common and specific data to the respective PNE(s)
- Non-CPNS Device Proxy

5.6.8 Service Group Management

5.6.8.1 Definition/role

This function provides the means to manage a Service Group.

5.6.8.2 Description

This function performs the following:

- Handles requests regarding Service Group management
- Manages Service Group membership
- Enables PNE and PN GW to request following:
 - Create and delete a Service Group
 - Invite and expel PNE(s) to/from a Service Group
 - Join and leave a Service Group

5.6.9 PN Management

5.6.9.1 Definition/role

This function provides the means to manage a Personal network, and to update PN Inventory.

5.6.9.2 Description

This function manages PN and PN Inventory.

PN Management functionality in CPNS Server performs following operations:

- Manage PN Inventory
- Handle request(s) from PNE for PN Inventory of local PN or remote PN
- Handle request(s) from PNE to join, leave establish and release PN
- Handle request(s) from PNE to invite and expel other PNEs
- Handle request(s) from PN GW to invite and expel PNE
- Handle request(s) from PN GW to establish and release PN
- Handle request(s) from PNE or PN GW to be PN Admin in a PN
- Handle request(s) from PN Admin to change Adminnee's information in PN Inventory
- Handle request(s) from PNE to switch current PNE to other PNE
- Handle request(s) from PNE or PN GW to change their Modes
- Handle request(s) from PN GW to switch to other PN GW
- Handle request(s) from PNE or PN GW to merge PNs or split a PN

PN Management functionality in PN GW performs following operations:

- Manage a local PN Inventory
- Handle / Initiate request(s) to establish and release a PN
- Handle / Initiate request(s) to invite /expel PNE(s) to/from the PN
- Handle / Initiate request(s) to be PN Admin in a PN
- Handle / Initiate request(s) from PN Admin to change Adminnee's information in PN Inventory

- Request to change its Mode
- Request to switch current PN GW to other PN GW
- Handle/Initiate Request to merge PNs or split a PN
- Match PNE and PN capabilities in order to facilitate the delivery of services

PN Management functionality in PNE performs following operations:

- Manage a local PN Inventory
- Request to invite / expel PNE(s) to/from PN
- Request to join / leave PN
- Request to establish and release PN
- Request to be PN Admin in a PN
- Request to change Admin's information in PN Inventory as PN Admin
- Request to switch current PNE to other PNE
- Request to change its Mode
- Request to merge PNs or split a PN

The PN Inventory may include list of PN(s) and the information of PNE(s) and PN GW(s) belonging to a PN. The information of PNE(s) contains device capability and information of service / content. The PN Inventory in CPNS Server can contain the information about PNs from multiple PN GWs, while the PN Inventory in a PN GW can contain the information of PN(s) belonging to the PN GW itself.

PN Admin can change Admin's configurations regarding PN information.

5.6.10 Non-CPNS Proxy

5.6.10.1 Definition/role

This function provides the means to support Non-CPNS Device to enable CPNS Services

5.6.10.2 Description

This document defines a proxy for non-CPNS Devices that enables them to consume services provided through CPNS, but which can't communicate using the protocols defined by CPNS Enabler. This is a proxy that allows the user to use suitable devices, for instance those supporting UPnP, DLNA and Bluetooth, to consume services provided by CPNS Enabler.

The proxy is implemented in the PN GW. The main purpose of the proxy is to make the devices look like PNEs when viewed from the CPNS Enabler. For example, in the case of UPnP/DLNA, this can be done by mapping the required CPNS functionality to the relevant UPnP/DLNA functions.

During the process of Non-CPNS Device Registration, this proxy function also facilitates to identify the available CPNS functionalities, which are deployed in the non-CPNS Devices. With the help of this function, the CPNS Device can communicate with the non-CPNS Device using some of those CPNS functionalities detected.

This function also helps when two CPNS entities are physically connected /paired through a non-CPNS Gateway, such as a legacy WiFi AP. Though, there is a non-CPNS Gateway in the middle of two CPNS entities, the transmission of messages,

creation of PN, provision of services, and additional process such as routing can be also possible, with the help of this proxy function.

This function performs the following:

- Non-CPNS Device registration/de-registration
- Service Publication and Discovery
- Service / Content Delivery

Appendix A. Change History (Informative)

A.1 Approved Version History

Reference	Date	Description
n/a	n/a	No prior version –or- No previous version within OMA

A.2 Draft/Candidate Version 1.1 History

Document Identifier	Date	Sections	Description
Draft Versions OMA-AD-CPNS-V1_1-20120214-D	14 Feb 2012	6.1.6	Initial Draft of CPNS 1.1 AD
Draft Versions OMA-AD-CPNS-V1_1-20120228-D	28 Feb 2012	5.3.1 5.3.2 5.5.10 Appendix G 3.2 Appendix C 5.3.2, 5.5 5.5.10 5.5.10 5.5.11 5.2 3.2	Incorporates input to committee: OMA-CD-CPNS-2012-0018R01- CR_AD_Modification_of_Functional_Components OMA-CD-CPNS-2012-0019- CR_AD_Modification_of_Functional_Interfaces OMA-CD-CPNS-2012-0020R01- CR_AD_Enhancement_of_PN_Management OMA-CD-CPNS-2012-0021-CR_AD_Adding_Typical_Flow OMA-CD-CPNS-2012-0022-CR_AD_Modification_of_Definitions OMA-CD-CPNS-2012-0023R01- CR_AD_Modification_of_Functional_Diagram OMA-CD-CPNS-2012-0029R01-CR_PNE_Switching OMA-CD-CPNS-2012-0030R01-CR_PN_GW_Switching OMA-CD-CPNS-2012-0031R01-CR_PN_Merging_and_Splitting OMA-CD-CPNS-2012-0032R01-CR_Non_CPNS_Proxy OMA-CD-CPNS-2012-0033R01-CR_Architecture_Diagram OMA-CD-CPNS-2012-0037R01-CR_Editorial_Changes OMA-CD-CPNS-2012-0040R01-CR_CPNS_Functionality
Draft Versions OMA-AD-CPNS-V1_1-20120502-D	02 May 2012	5.5.10.2 5.5.10.2 5.5.9.2 5.4 5.5.4.2 B.2.3 5.1, 5.3.2.1, 5.3.2.6	Incorporates input to committee: OMA-CD-CPNS-2012-0064R01-CR_Non_CPNS_Proxy1 OMA-CD-CPNS-2012-0065R01-CR_Non_CPNS_Proxy2 OMA-CD-CPNS-2012-0069R01-CR_AD_PN_Admin OMA-CD-CPNS-2012-0070R01-CR_AD_Resolution_for_A027 OMA-CD-CPNS-2012-0071R01-CR_AD_Resolution_for_A031 OMA-CD-CPNS-2012-0072R01-CR_Resoultion_of_A042 OMA-CD-CPNS-2012-0073R01- CR_Resolution_of_CPNS_1.1_AD_review_comment_A028
Draft Versions OMA-AD-CPNS-V1_1-20120507-D	07 May 2012	5.5	Incorporates input to committee: OMA-CD-CPNS-2012-0074R01- CR_Charging_Considerations_for_CPNS
Candidate version	29 May 2012	All	Status changed to Candidate by TP ref #: OMA-TP-2012-0208-INP_CPNS_V1.1_AD_for_Candidate_Approval

Appendix B. CPNS Logical Entities and Physical Entities(Informative)

B.1 Terminology

In the figures in this appendix, interior boxes represent logical entities, and exterior boxes represent physical entities. The terms 'Mobile Phone', 'PMP' and 'Server' refer to physical entities. The logical CPNS Server entity is referred to as 'CS', and "Application/Content Entity" (ACE) refers to the entities (external to CPNS) that use CPNS to consume and offer services.

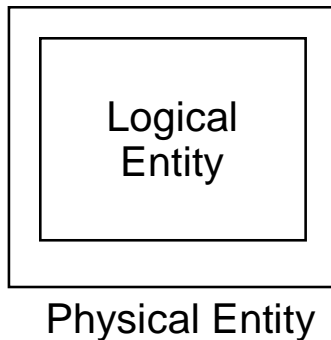

Figure 2: CPNS Logical Entities and Physical Entities

B.2 Client-Server Deployment Examples

B.2.1 Basic Client-Server Deployment

The first deployment example shows a basic client-server deployment with a CPNS logical entity in Mobile Phone A, Mobile Phone B and Server 1.

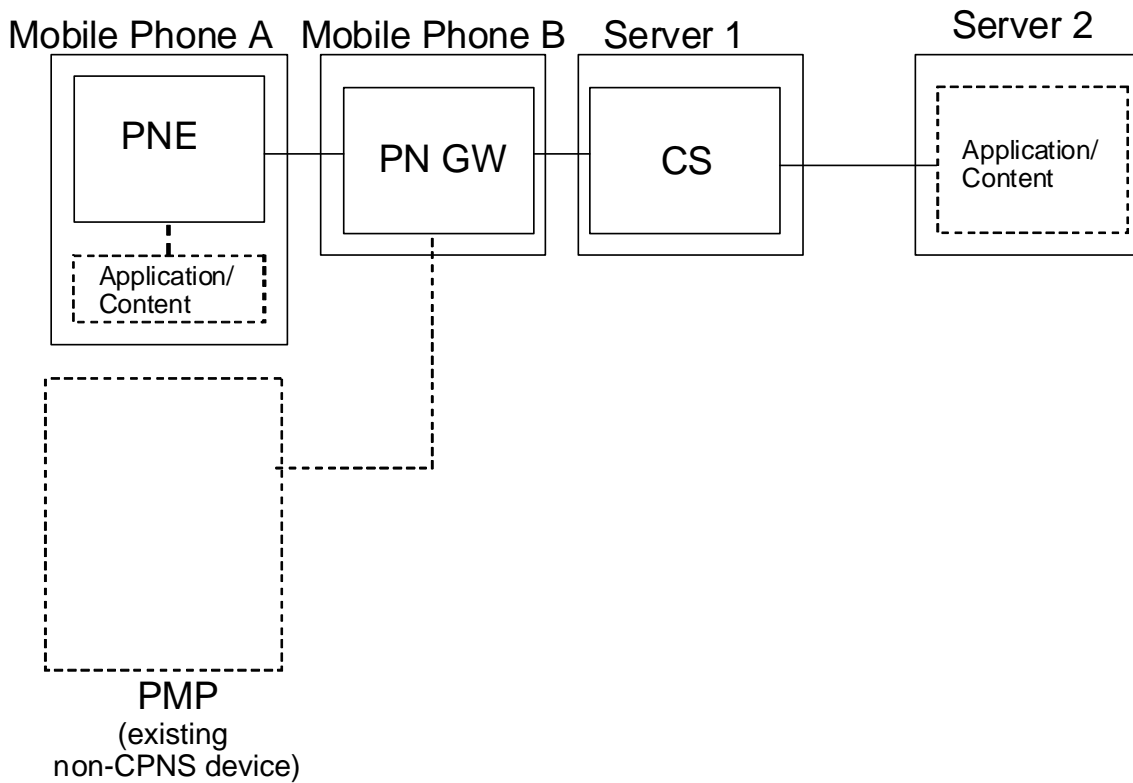

Figure 3: Basic Client-Server Deployment

B.2.2 Client-Server Deployment with Combined PNE & PN GW

The second deployment example shows the same client-server deployment as in the first example, except that Mobile Phone B is a smart phone that can also offer and consume CPNS services in addition to the PN GW role.

To enable this, Mobile Phone B on the next slide assumes the additional role of a PNE so that it can interface with the ACE(s) on Mobile Phone B that offer and consume services

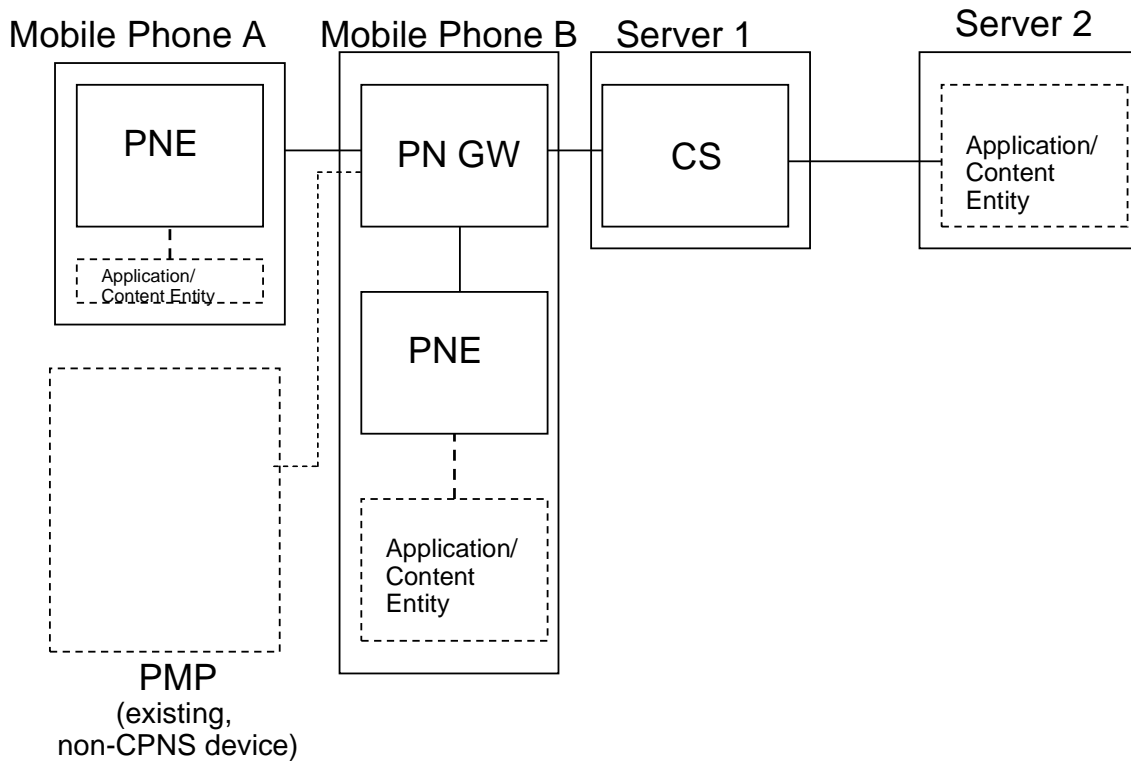

Figure 4: Client-Server Deployment with Combined PNE & PN GW

B.2.3 Client-Server Deployment using Non-CPNS gateway (e.g. WiFi AP)

The third deployment example shows the same client-server deployment as in the first example, except that two CPNS Devices are connected via Non-CPNS gateway physically. The PN GW in the Device A and the PNE in the Device B can be logically connected with the help of Non-CPNS Proxy function.

To enable this, Device A has both the PNE and the PN GW and Device B has the PNE entity. The PN GW in the Device A will be connected to the CPNS Server.

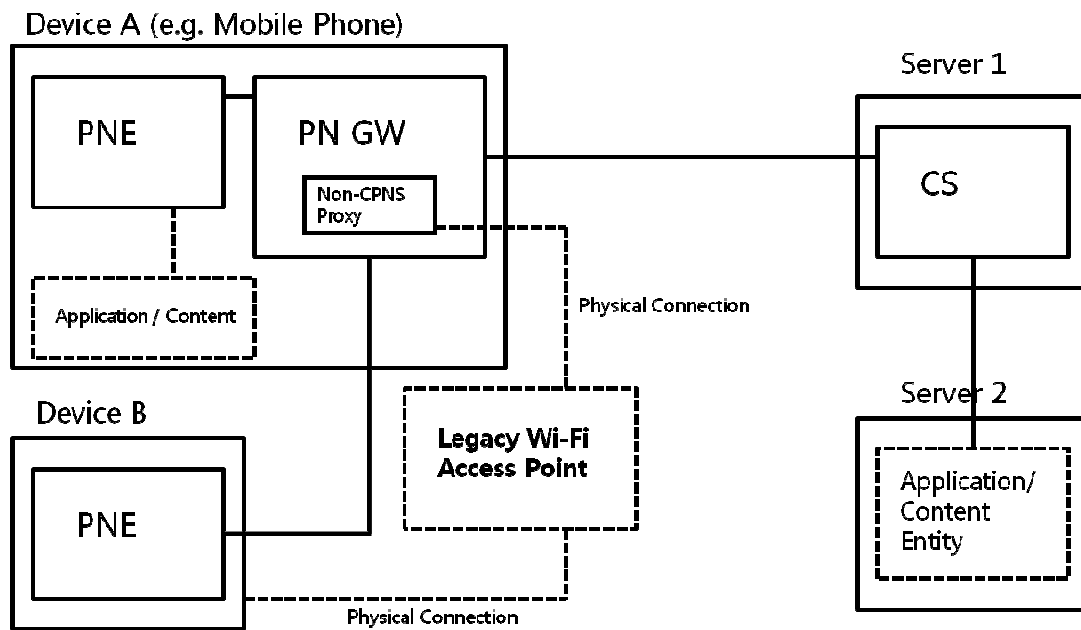

Figure 5: Client-Server Deployment using non-CPNS Gateway (e.g. Legacy WiFi Access Point)

B.3 Peer-to-Peer Deployment Example (Deferred for future release)

B.3.1 Peer-to-Peer Deployment with Dedicated Authentication/Authorisation Server

A CPNS deployment in which the CS Service Publication and Discovery is implemented on the Devices in a CPNS network, while the CS AUC/AUZ function is performed by a Server

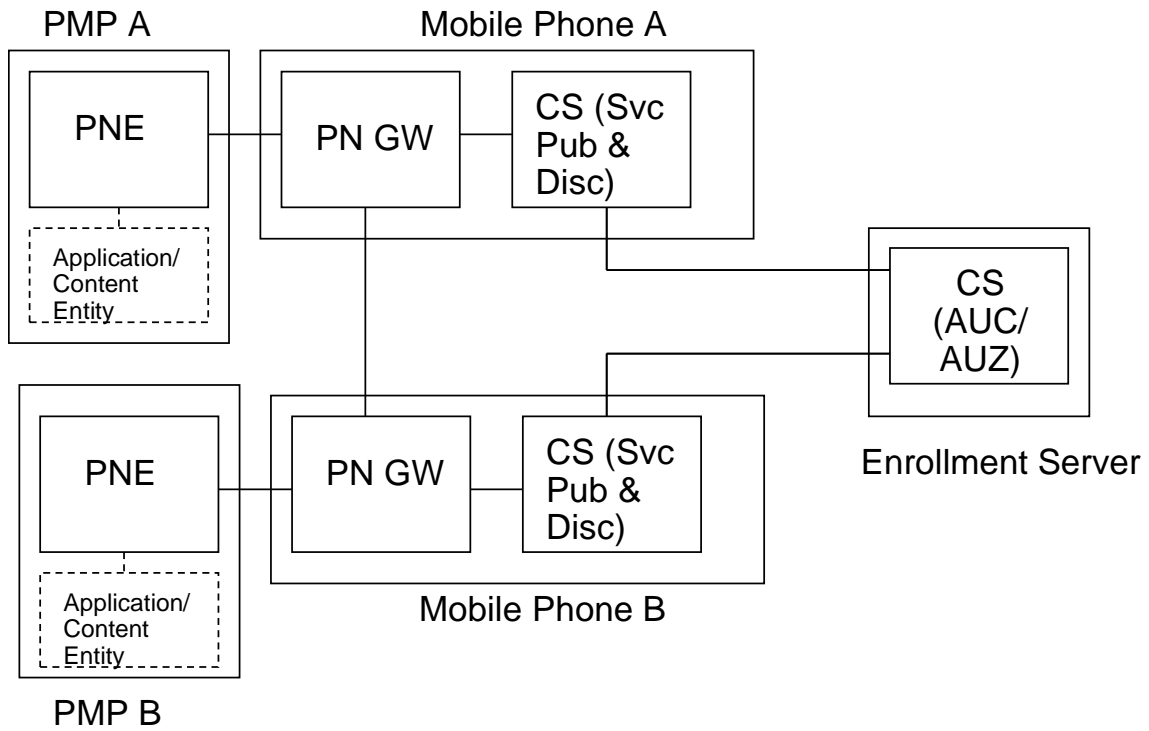

Figure 6: Peer-to-Peer Deployment with Dedicated Authentication/Authorisation Server

Appendix C. Functional Diagram (Informative)

This figure shows the functional diagram of OMA CPNS v1.1

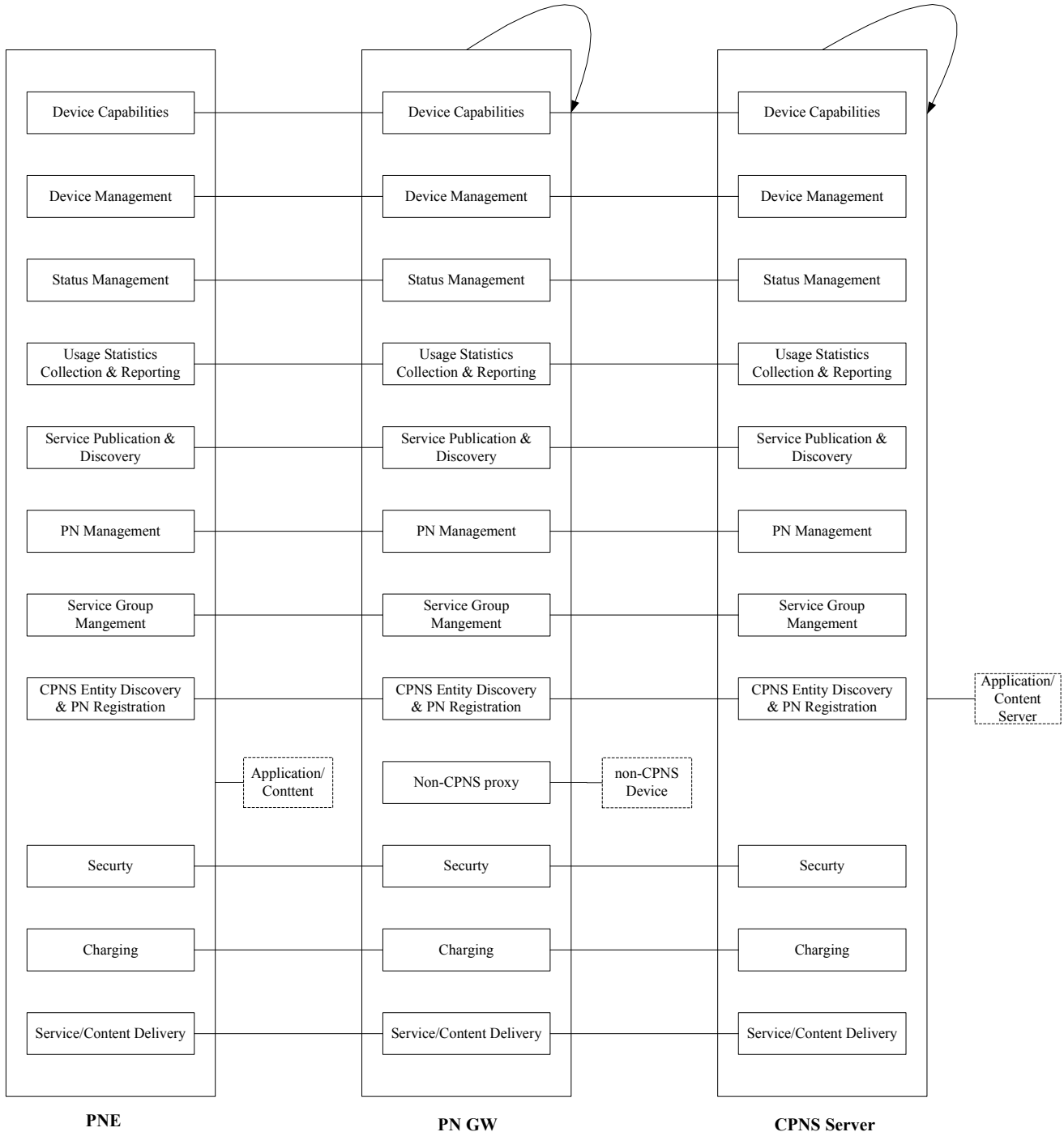

Figure 7: Functional diagram

Appendix D. Feasibility study of security of CPNS interfaces when utilizing underlying network security mechanisms (Informative)

As described in section 5.3.1.9, CPNS Enabler can utilize security mechanisms provided by underlying network infrastructures to ensure communication security in CPNS. This section shows an example scenario where CPNS Enabler ensures security by utilizing security mechanisms of underlying network infrastructures.

D.1 System Assumption

Figure 15 shows an example of the proposed security platform. Underlying network infrastructures assumed in this example are as follows.

- WAN

As the underlying WAN infrastructure, IMS (IP Multimedia Subsystem) is deployed. Since IMS provides security mechanisms, which will be described later in the next sub section, WAN in this example is a secure WAN.

CPNS Servers and PN GWs connect to IMS as IMS application servers (ASs) and subscribers, respectively.

- PN

It is assumed that PN technologies with security mechanisms are used. Examples of such PN technologies include WiFi and Bluetooth [IEEE802.11i, Bluetooth Security White Paper].

PN GWs and PNEs are connected by using those technologies.

Communication of each CPNS interface is conducted on the following network infrastructures.

- CPNS-1,6: PN technologies with security mechanisms
- CPNS-2, 3 and 7: IMS (secure WAN)
- CPNS-4: The Internet (non-secure WAN)

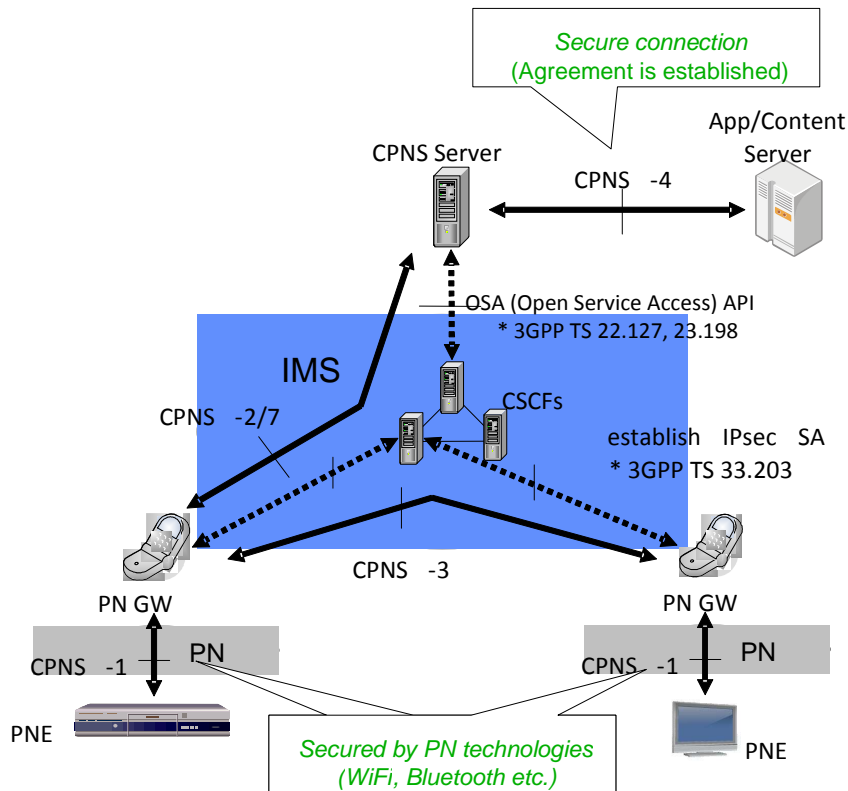

Figure 8: System assumption

D.2 Security of CPNS Interfaces

D.2.1 CPNS-1, 6

When using WiFi as the PN technology, one of typical ways to ensure security of CPNS-1,6 is to pre-configure a shared secret key like a WEP key in both PN GW and PNE before starting communication. By doing this, PN GW and PNE can authenticate with each other and data confidentiality and integrity can be also ensured.

When using Bluetooth as the PN technology, PN GW and PNE can establish a secure connection by means of the initial pairing process. During this process, a user enters a PIN code to one or both of them, which is used to generate a secure key, which is then used for authentication and ensuring data confidentiality and integrity.

D.2.2 CPNS-2, 3 and 7

Security of CPNS-2, 3 and 7 can be ensured by IMS security mechanisms. Two different scenarios can be assumed: (1) Messages of the CPNS interfaces are exchanged using IMS signalling channel (i.e. C-plane) and (2) Messages of the CPNS interfaces are exchanged using IMS media channel (i.e. U-plane). The following sub sections explain how security is ensured in those scenarios.

D.2.2.1 Using IMS signaling channel

When PN GWs registers with IMS, PN GWs and IMS authenticate each other and establish secure connections by IPsec [3GPP TS 33.203]. By using the secure connections, PN GWs can securely send or receive SIP messages to/from IMS. When CPNS Servers connect with IMS via OSA (Open Service Access) API [3GPP TS 22.127, 3GPP TS 23.198], providers of CPNS Servers need to establish service agreements with IMS providers. The service agreements require that CPNS Servers

and SCS (Service Capability Server) on IMS authenticate each other and establish secure connections by IPSec or SSL. As a result, since SIP messages between PN GWs and CPNS Servers are passed through the IPSec connection between PN GWs and IMS and the secure connection between IMS and CPNS Servers, data confidentiality and integrity of CPNS signalling messages can be ensured.

D.2.2.2 Using IMS media channel

IMS media channel security between UEs has been almost standardized in 3GPP [3GPP TS 33.328]. In the specification, there are two solutions, including solutions based on Key Management Service (KMS) and Session Description Protocol Security Descriptions (SDS). By applying these solutions, communication in the CPNS-3 can be secured.

D.2.3 CPNS-4

In the system assumption described in B.1, CPNS Servers and application/content servers connects with each other through the Internet (non-secure WAN). In order to provide secure content/service delivery services over the non-secure WAN, providers of CPNS Servers and application/content servers conclude security agreements. In such a scenario, secure connection can be based on IPSec or SSL between CPNS Servers and application/content servers. During the establishment of secure connection, CPNS Servers and application/content servers can authenticate with each other. After the establishment, data confidentiality and integrity can be also ensured.

Appendix E. Service Publication & Discovery overview (informative)

E.1 Introduction

This clause provides supplemental description of Service Publication & Discover function.

E.2 Description

There are three functional entities in Service Publication and Discovery: a) a metadata directory which stores service descriptions and/or keywords, b) a publisher, used by the service offerer to publish information about services to the metadata directory, and c) a discoverer, used by the service consumer to discover information about services from the metadata directory.

An example of a metadata directory is one that is maintained on the network- based CPNS Server or an external entity. An illustration of the above functions, and associated interactions, is shown in Figure 8 as below:

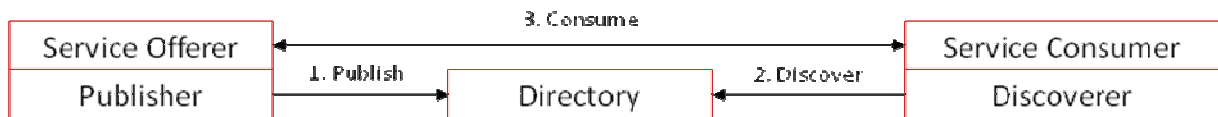

Figure 9: High level architecture of Service Publication and Discovery functionality and operations

E.3 DHT and Overlay Routing

In the deployment of distributed metadata directory, in order for either the service offerer to publish service information to, or the service consumer to discover service information from, the peer node responsible for the affiliated resource, overlay routing is performed. This operates by each responsible node (starting with the service offerer for publication, or service consumer for discovery) on the overlay routing the message to the finger closest to the destination node. An example of an 8-node DHT (Distributed Hash Table – see [P2PSIP Internet-Draft]) is shown in Fig. Y below, whereby node 100 is assumed to be either the service offerer or the service consumer, and node 800 contains the metadata directory. In this example, three hops are required to route the Service Publication or Discovery message from node 100 to node 800. It is assumed that each node in the diagram contains an integrated PN GW function that supports the overlay routing.

3-hop routing from node 100 to 800
(100 has 200, 300 and 500 as its fingers):

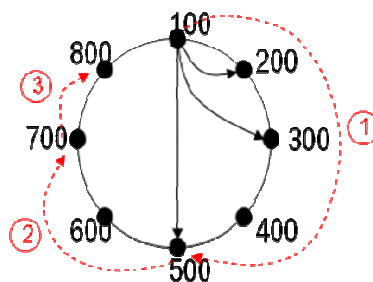

Figure 10: Example 8-node DHT and related overlay routing for Service Publication or Discovery

Appendix F. Zone Based Service (Informative)

F.1 Zone

The Zone in the CPNS service represents the specific geographic area which is determined by users or by the signalling capacities of bearer used. The Zone provides specific service/contents using a certain allocated PN GW.

In case of many CPNS users with their PNE(s) are located in the same Zone, the PNE(s) respectively constructs the Personal Network with the allocated Zone PN GW. The Zone PN GW may belong to the numerous PN(s).

F.2 Push service using the Zone PN GW

The Zone Based Service facilitates the content push service with CPNS enabler.

When the PNE comes to the Zone, with the CPNS Entity Discovery and PN Registration function, the PNE is discovered by the PN GW and registered in the PN inventory of the CPNS server without receiving the request from PNE or input from the user.

Only by setting to reply on the PN GW's periodic search, a PNE can be pushed the contents or the service description information.

This service needs several preconditions described below:

- The target PNE(s) should be subscribed and authorized for the service beforehand.
- The target PNE(s) can be discovered, connected and serviced, only when allowed by the user(s).
- The PN GW should check if the PNE is available for pushing content.

Appendix G. Typical Flow (Informative)

G.1 CPNS Typical Flow

The CPNS typical flow shows general sequences of CPNS functions to perform CPNS Service as general. This flow includes CPNS Entity Discovery and PN Registration, Service Publication & Discovery, Service/Content Delivery with Device Capability and Usage Statistics Collecting & Reporting.

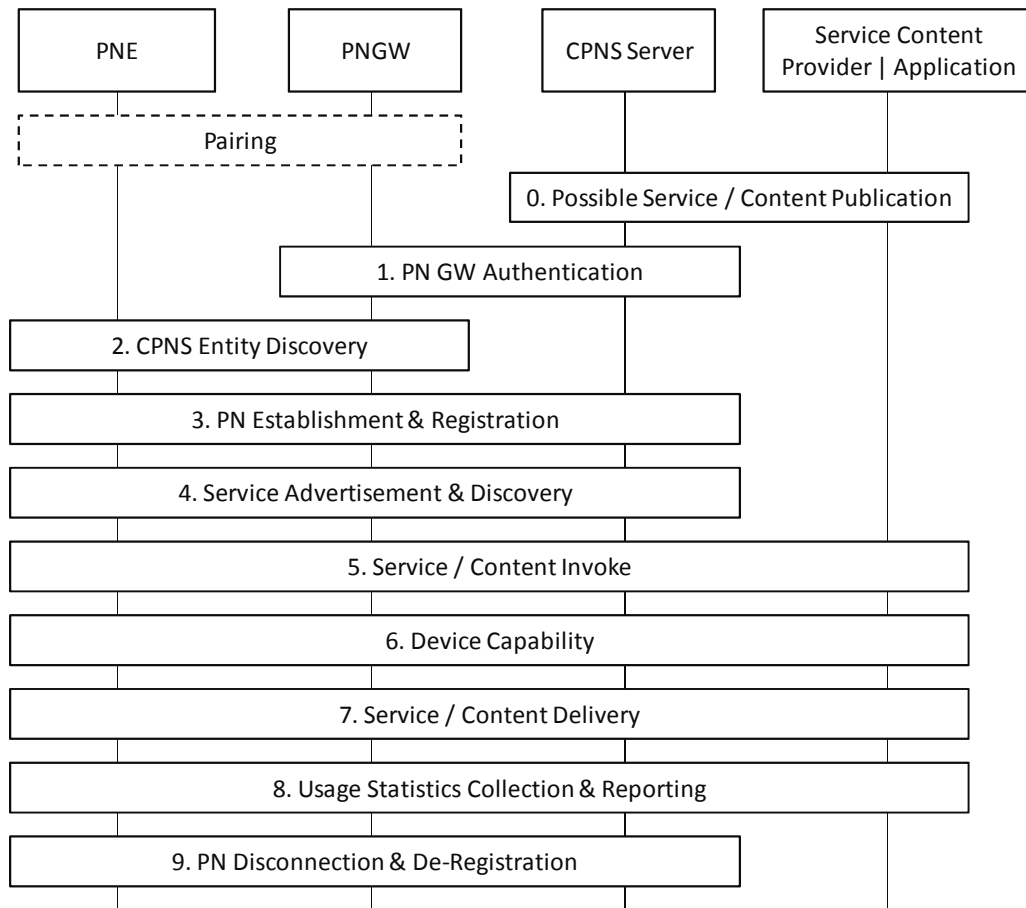

Figure 11: CPNS typical flow

A physical connection (pairing) with PAN technologies between the PNE and the PN GW should be established before CPNS message is sent. It assumes that the PNE in the above diagram and text below is the first PNE which participates in the PN.

0. The Service/Content Provider or application publishes the Service Description to the CPNS Server whenever the service and content is available.
1. The PN GW is authenticated by the CPNS Server. This process can be done before or after the pairing between PN GW and PNE.
2. The PNE or the PN GW initiates CPNS Entity Discovery. This enables discovery of the current operational CPNS Mode (PNE or PN GW) in a CPNS device.
3. PNE and PN GW connect to each other through a PN. The PN GW creates the information about the corresponding PN that is sent to the CPNS Server and stored in its PN Inventory.. Part of this PN information is sent by CPNS Server to the associated PN GW

4. The CPNS Server advertises Service Description to the PNE or the PNE queries Service Description to the CPNS Server.
5. The PNE invokes service based on the Service Description provided by the CPNS Server.
6. The information of device capability of the PNE, which consumes service or content, may be shared with the CPNS Server and/or Service/Content Provider for delivery of service and content.
7. The service or content is delivered to the PNE from the Service/Content Provider.
8. The PNE reports all the information on the service usage from the CPNS device based on user preference or Operator Policy. The CPNS Server collects the report from the PNE(s) with the related user information.
9. The PNE or the PN GW requests disconnection with the PN. Then, the PN GW de-registers to the CPNS Server on behalf of the PNE.