



# DM Smart Card Architecture

## Approved Version 1.0 – 30 Oct 2012

---

**Open Mobile Alliance**  
OMA-AD-DM\_SC-V1\_0-20121030-A

Use of this document is subject to all of the terms and conditions of the Use Agreement located at <http://www.openmobilealliance.org/UseAgreement.html>.

Unless this document is clearly designated as an approved specification, this document is a work in process, is not an approved Open Mobile Alliance™ specification, and is subject to revision or removal without notice.

You may use this document or any part of the document for internal or educational purposes only, provided you do not modify, edit or take out of context the information in this document in any manner. Information contained in this document may be used, at your sole risk, for any purposes. You may not use this document in any other manner without the prior written permission of the Open Mobile Alliance. The Open Mobile Alliance authorizes you to copy this document, provided that you retain all copyright and other proprietary notices contained in the original materials on any copies of the materials and that you comply strictly with these terms. This copyright permission does not constitute an endorsement of the products or services. The Open Mobile Alliance assumes no responsibility for errors or omissions in this document.

Each Open Mobile Alliance member has agreed to use reasonable endeavors to inform the Open Mobile Alliance in a timely manner of Essential IPR as it becomes aware that the Essential IPR is related to the prepared or published specification. However, the members do not have an obligation to conduct IPR searches. The declared Essential IPR is publicly available to members and non-members of the Open Mobile Alliance and may be found on the “OMA IPR Declarations” list at <http://www.openmobilealliance.org/ipr.html>. The Open Mobile Alliance has not conducted an independent IPR review of this document and the information contained herein, and makes no representations or warranties regarding third party IPR, including without limitation patents, copyrights or trade secret rights. This document may contain inventions for which you must obtain licenses from third parties before making, using or selling the inventions. Defined terms above are set forth in the schedule to the Open Mobile Alliance Application Form.

**NO REPRESENTATIONS OR WARRANTIES (WHETHER EXPRESS OR IMPLIED) ARE MADE BY THE OPEN MOBILE ALLIANCE OR ANY OPEN MOBILE ALLIANCE MEMBER OR ITS AFFILIATES REGARDING ANY OF THE IPR'S REPRESENTED ON THE “OMA IPR DECLARATIONS” LIST, INCLUDING, BUT NOT LIMITED TO THE ACCURACY, COMPLETENESS, VALIDITY OR RELEVANCE OF THE INFORMATION OR WHETHER OR NOT SUCH RIGHTS ARE ESSENTIAL OR NON-ESSENTIAL.**

**THE OPEN MOBILE ALLIANCE IS NOT LIABLE FOR AND HEREBY DISCLAIMS ANY DIRECT, INDIRECT, PUNITIVE, SPECIAL, INCIDENTAL, CONSEQUENTIAL, OR EXEMPLARY DAMAGES ARISING OUT OF OR IN CONNECTION WITH THE USE OF DOCUMENTS AND THE INFORMATION CONTAINED IN THE DOCUMENTS.**

© 2012 Open Mobile Alliance Ltd. All Rights Reserved.

Used with the permission of the Open Mobile Alliance Ltd. under the terms set forth above.

# Contents

- 1. SCOPE (INFORMATIVE) .....4**
- 2. REFERENCES .....5**
  - 2.1 NORMATIVE REFERENCES.....5**
  - 2.2 INFORMATIVE REFERENCES.....5**
- 3. TERMINOLOGY AND CONVENTIONS .....6**
  - 3.1 CONVENTIONS.....6**
  - 3.2 DEFINITIONS.....6**
  - 3.3 ABBREVIATIONS.....6**
- 4. INTRODUCTION (INFORMATIVE).....7**
  - 4.1 VERSION 1.0 .....7**
  - 4.2 SECURITY CONSIDERATIONS.....7**
- 5. ARCHITECTURAL MODEL.....8**
  - 5.1 DEPENDENCIES.....8**
  - 5.2 ARCHITECTURAL DIAGRAM .....8**
  - 5.3 FUNCTIONAL COMPONENTS AND INTERFACES/REFERENCE POINTS DEFINITION.....9**
    - 5.3.1 Components .....9
    - 5.3.2 Interfaces.....9
  - 5.4 FLOWS .....9**
    - 5.4.1 Data provisioning triggered by the management authority .....9
- APPENDIX A. CHANGE HISTORY (INFORMATIVE).....11**
  - A.1 APPROVED VERSION HISTORY .....11**
- APPENDIX B. MANAGEMENT AUTHORITY DIAGRAM (INFORMATIVE) .....12**
  - B.1 ADDITIONAL COMPONENTS.....12**
    - B.1.1 DM Client .....12
    - B.1.2 DM Server.....13
    - B.1.3 DM\_SC Gateway .....13
  - B.2 ADDITIONAL INTERFACES .....13**
    - B.2.1 DM-3: DM Bootstrap Profile.....13
    - B.2.2 CP-1: CP Bootstrap Profile .....13
    - B.2.3 DM-1: DM Client Server Protocol.....13
    - B.2.4 Update Provisioning Data: External Card Management System .....13

# Figures

- Figure 1: Device Management Smart Card Component Architecture .....8**
- Figure 2: Architecture using interfaces .....12**

# 1. Scope

**(Informative)**

This document describes how the Device Management Smart Card enabler fits with the other OMA Device Management Enablers, starting with the DM 1.2 Enabler that it complements using the smart card features for better immediacy of service provisioning, portability of device configuration and security of Device Management operations.

## 2. References

### 2.1 Normative References

- [DM\_SC-RD] “DM Smart Card Requirements”, Open Mobile Alliance™, OMA-RD-DM\_SC-V1\_0, URL:<http://www.openmobilealliance.org/>
- [DM1.2] “Enabler Release Definition for OMA Device Management”, Open Mobile Alliance™, OMA-ERELED-DM-V1\_2, URL:<http://www.openmobilealliance.org/> URL: <http://www.openmobilealliance.org/>
- [DMBOOT] “OMA Device Management Bootstrap”, OMA-TS-DM-Bootstrap-V1\_2, Open Mobile Alliance™, URL:<http://www.openmobilealliance.org/>
- [DMNOTI] “OMA Device Management Notification Initiated Session”, OMA-TS-DM\_Notification-V1\_2, Open Mobile Alliance™, URL:<http://www.openmobilealliance.org/>
- [DMSTDOBJ] “OMA Device Management Standardized Objects”, OMA-TS-DM-StdObj-V1\_2, Open Mobile Alliance™, URL:<http://www.openmobilealliance.org/>
- [DMTND] “OMA Device Management Tree and Description”, OMA-TS-DM-TND-V1\_2, Open Mobile Alliance™, URL:<http://www.openmobilealliance.org/>
- [DMTNS] “OMA Device Management Tree and Description Serialization”, OMA-TS-DM-TNDS-V1\_2, Open Mobile Alliance™, URL:<http://www.openmobilealliance.org/>
- [OMA-DICT] “OMA Dictionary”, OMA-ORG-Dictionary-V2\_7, Open Mobile Alliance™, URL:<http://www.openmobilealliance.org/>
- [PROVSC] “Provisioning Smartcard Candidate Version 1.1”, OMA-WAP-TS-ProvSC-V1\_1, Open Mobile Alliance™, URL:<http://www.openmobilealliance.org/>
- [RFC2119] “Key words for use in RFCs to Indicate Requirement Levels”, S. Bradner, March 1997, URL:<http://www.ietf.org/rfc/rfc2119.txt>
- [SCWS] “Enabler Release Definition for Smartcard-Web-Server”, Open Mobile Alliance, OMA-ERELED\_Smartcard\_Web\_Server-V1\_1, URL:<http://www.openmobilealliance.org/> URL: <http://www.openmobilealliance.org/>

### 2.2 Informative References

- [ARCH-PRINC] “OMA Architecture Principles”, OMA-ArchitecturePrinciples-V1\_2, ”, Open Mobile Alliance™, URL:<http://www.openmobilealliance.org/>

## 3. Terminology and Conventions

### 3.1 Conventions

The key words “MUST”, “MUST NOT”, “REQUIRED”, “SHALL”, “SHALL NOT”, “SHOULD”, “SHOULD NOT”, “RECOMMENDED”, “MAY”, and “OPTIONAL” in this document are to be interpreted as described in [RFC2119].

All sections and appendixes, except “Scope” and “Introduction”, are normative, unless they are explicitly indicated to be informative.

### 3.2 Definitions

<b>Card Issuer</b>	See [DM_SC-RD].
<b>Interface</b>	See [OMA-DICT].
<b>Management Tree</b>	See [DMTND].

### 3.3 Abbreviations

<b>CI</b>	Card Issuer
<b>CSIM</b>	CDMA2000 Subscriber Identity Module
<b>DM</b>	Device Management
<b>OMA</b>	Open Mobile Alliance
<b>OTA</b>	Over-the-air
<b>R-UIM</b>	Removable User Identity Module
<b>SC</b>	Smart Card
<b>SIM</b>	Subscriber Identity Module
<b>USIM</b>	Universal Subscriber Identity Module

## 4. Introduction (Informative)

The Device Management technology provides an infrastructure to perform remote operations of configuration and servicing of devices on behalf of the end-user. In the scope of the DM SC enabler, these operations can be seen under two perspectives:

- Life Cycle: As they can be performed during the initialization phase of the device (when limited or no configuration is present) or after that initialization during the rest of the life cycle of the device.
- Security: As they can involve the use of end-user identities, credentials or data, which, by nature, must be securely administrated.

In the context of wireless networks, a Smart Card (e.g. SIM, USIM, R-UIM, CSIM) provides added value to management authorities and end-users (e.g. portability, authentication, non-repudiation, etc) and is the central element of this enabler that aims to describe an architecture that:

- Extend the provisioning capabilities of the Smart Card to cover more of the life cycle of devices in benefit of management authorities and end-users.
- Enforce the security of Device Management related operations

### 4.1 Version 1.0

The OMA Principles [ARCH-PRINC] are considered in order to produce a broad, secure, scalable and bearer agnostic architecture in which existent technologies are re-used as much as possible.

### 4.2 Security Considerations

This enabler addresses the following security threats:

- Network Operators and Enterprise Administrators protection from malicious remote servers trying to “inject” faulty configuration into devices.
- End-user protection through a mechanism that allows a configurable confirmation request for operations involving charging and/or end-user data manipulation.
- Data protection through a mechanism that allows a configurable ciphering.
- Business protection through a mechanism that provides non-repudiation of Customer Care operations.

## 5. Architectural Model

### 5.1 Dependencies

The following dependencies are identified:

Work Item	Short name	Details
Device Management	DM 1.2	See [DM1.2]
Smart Card Web Server	SCWS 1.1	See [SCWS]

### 5.2 Architectural Diagram

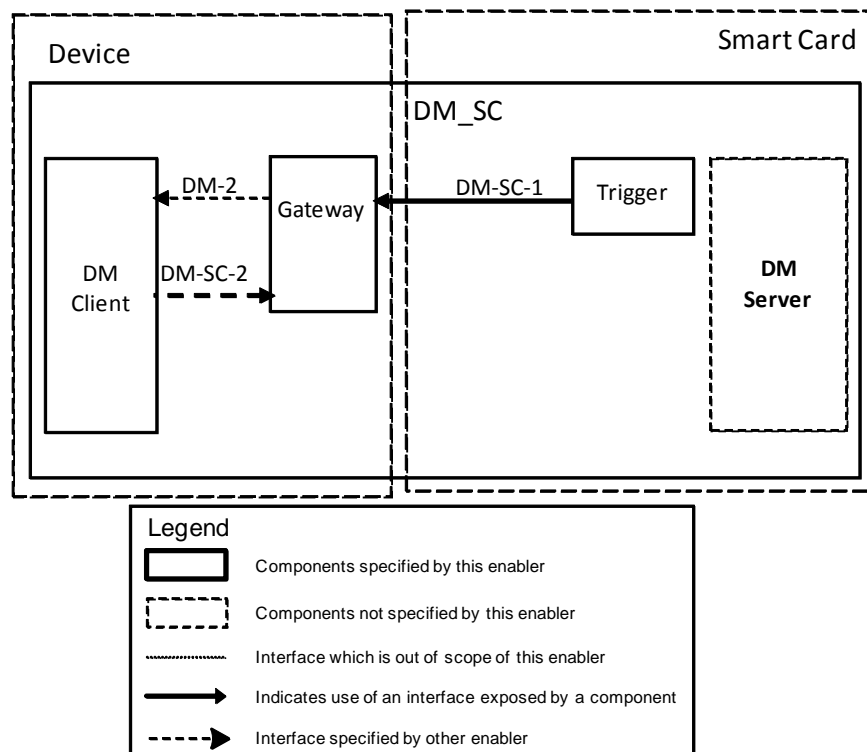

Figure 1: Device Management Smart Card Component Architecture



## 5.3 Functional Components and Interfaces/reference points definition

### 5.3.1 Components

#### 5.3.1.1 DM\_SC Trigger

This component conveys a DM Notification (see [DM1.2]) from the smart card to the DM Client. For a complete view of the relationship between this component and other DM Enabler (see [DM1.2]) components and interfaces please refer to Appendix B.

#### 5.3.1.2 DM\_SC Gateway

This component conveys transparently a DM Notification from the DM\_SC Gateway to a DM Client registered as *launchable* in the Card Application Toolkit framework. As the Smart card needs to interact with it to deal with error cases it appears as a bold box in the architecture diagram.

#### 5.3.1.3 DM Client

The DM Client is specified in the OMA Device Management Enabler. As this specification requires the support of the Notification feature, HTTP, as well as the registration of the DM Client in the Card Application Toolkit framework, this component appears as a bold box in the architectural diagram.

### 5.3.2 Interfaces

#### 5.3.2.1 DM-SC-1: Smartcard triggering Interface

This interface allows the smartcard to trigger the DM Client in order to start a DM session.

#### 5.3.2.2 DM-SC-2: Registration Interface

This interface allows the DM Client to register as *launchable* application in the Card Application Toolkit framework.

## 5.4 Flows

The Device Management Smart Card architecture relies on the OMA Device Management enabler [DM1.2] but requires particular data flows for interfacing the DM Client with the smartcard as shown in Figure 1. The following logical flows provide a high level view of the exchanges needed to satisfy the DM\_SC requirements and use-cases (as described in [DM\_SC-RD]). Readers are referred to those documents for further information.

The update of provisioning data in the smartcard is out of the scope of this enabler (see Appendix B).

### 5.4.1 Data provisioning triggered by the management authority

The following flows describe the exchanges between the DM Client and the smartcard needed to perform data provisioning. The data provisioning in this section does not refer to bootstrap data, which is covered in [DMBOOT] and can be provisioned using different mechanisms.

#### 5.4.1.1 Normal Flow: Remote trigger for data provisioning

As data is stored at an unknown location the provisioning needs the smartcard to temporarily play a role of master in the session.

1. The External Card Management System sends a remote push notification to the DM Client.
2. The DM Client opens a DM session with the smartcard
3. The smartcard sends provisioning data to the DM Client

4. Optionally, end-user interaction messages may be used
5. The DM Client integrates provisioning data into its configuration
6. The DM Client provides results to the smartcard

#### **5.4.1.2 Alternate Flow: Local Trigger for data provisioning**

As data is stored at an unknown location the provisioning needs the smartcard to temporarily play a role of master in the session.

1. An event triggers the smartcard (e.g. as a timer expiration)
2. The smartcard informs the DM Client about the need of a DM session
3. Same steps as in Normal Flow (steps 2 to 6)

## Appendix A. Change History

(Informative)

### A.1 Approved Version History

Reference	Date	Description
OMA-AD-DM_SC-V1_0-20121030-A	30 Oct 2012	Approved by TP Ref TP Doc# OMA-TP-2012-0380- INP_DM_Smart_Card_V1_0_ERP_for_Final_Approval

## Appendix B. Management Authority Diagram (Informative)

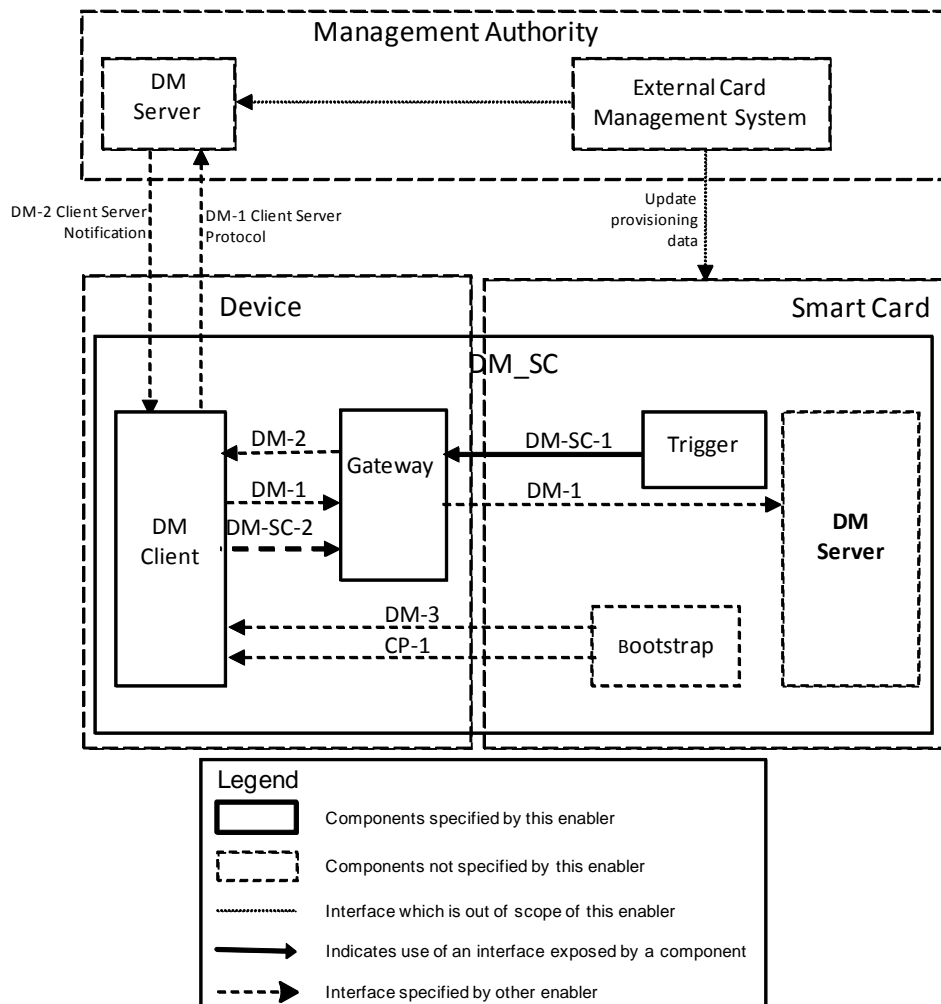

Figure 2: Architecture using interfaces

### B.1 Additional Components

#### B.1.1 DM Client

The DM Enabler allows the Management of the Device configuration and other Managed Objects of Devices from the point of view of the various Management Authorities. DM includes, but is not restricted to setting initial configuration information in Devices, subsequent updates of persistent information in Devices, retrieval of management information from Devices and processing events and alarms generated by Devices (see [DM1.2]).

The DM Client is specified in the OMA Device Management Enabler. As this specification requires the support of the Notification feature, HTTP, as well as the registration of the DM Client in the Card Application Toolkit framework, this component appears as a bold box in the architectural diagram.

## B.1.2 DM Server

The DM Server is the component that conforms to the requirements for DM Servers specified in the OMA Device Management Enabler.

## B.1.3 DM\_SC Gateway

This component conveys transparently a DM Notification from the DM\_SC Gateway to a DM Client registered as *launchable* in the Card Application Toolkit framework. As the Smart card needs to interact with it to deal with error cases it appears as a bold box in the architecture diagram.

## B.2 Additional Interfaces

### B.2.1 DM-3: DM Bootstrap Profile

This interface is defined in the DM enabler (i.e. [DMBOOT]). It enables the SC to convey bootstrap information to the DM Client. The bootstrap information can consist of a single object (i.e. DMAccount as in [DMSTDOBJ] and [DMTND]) or a set of serialized objects (as in [DMTNDs]).

### B.2.2 CP-1: CP Bootstrap Profile

Depending on the device implementation, and as indicated in the DM enabler (i.e. [DMBOOT]), the bootstrap information could optionally consist of application characteristics documents (see [PROVSC]). This interface enables the SC to convey bootstrap information to the DM Client.

### B.2.3 DM-1: DM Client Server Protocol

This interface allows DM Servers to send device management commands to DM Clients and DM Clients may return status and alerts to DM Servers (see [DM1.2]).

### B.2.4 Update Provisioning Data: External Card Management System

It enables a remote and secure updating of the SC. The interaction with the SC and the DMS is out of the scope of this enabler.