



OMA DPE Management Object

Approved Version 1.0 – 05 Jul 2011

Open Mobile Alliance
OMA-TS-DPE_MO-V1_0-20110705-A

Use of this document is subject to all of the terms and conditions of the Use Agreement located at <http://www.openmobilealliance.org/UseAgreement.html>.

Unless this document is clearly designated as an approved specification, this document is a work in process, is not an approved Open Mobile Alliance™ specification, and is subject to revision or removal without notice.

You may use this document or any part of the document for internal or educational purposes only, provided you do not modify, edit or take out of context the information in this document in any manner. Information contained in this document may be used, at your sole risk, for any purposes. You may not use this document in any other manner without the prior written permission of the Open Mobile Alliance. The Open Mobile Alliance authorizes you to copy this document, provided that you retain all copyright and other proprietary notices contained in the original materials on any copies of the materials and that you comply strictly with these terms. This copyright permission does not constitute an endorsement of the products or services. The Open Mobile Alliance assumes no responsibility for errors or omissions in this document.

Each Open Mobile Alliance member has agreed to use reasonable endeavors to inform the Open Mobile Alliance in a timely manner of Essential IPR as it becomes aware that the Essential IPR is related to the prepared or published specification. However, the members do not have an obligation to conduct IPR searches. The declared Essential IPR is publicly available to members and non-members of the Open Mobile Alliance and may be found on the “OMA IPR Declarations” list at <http://www.openmobilealliance.org/ipr.html>. The Open Mobile Alliance has not conducted an independent IPR review of this document and the information contained herein, and makes no representations or warranties regarding third party IPR, including without limitation patents, copyrights or trade secret rights. This document may contain inventions for which you must obtain licenses from third parties before making, using or selling the inventions. Defined terms above are set forth in the schedule to the Open Mobile Alliance Application Form.

NO REPRESENTATIONS OR WARRANTIES (WHETHER EXPRESS OR IMPLIED) ARE MADE BY THE OPEN MOBILE ALLIANCE OR ANY OPEN MOBILE ALLIANCE MEMBER OR ITS AFFILIATES REGARDING ANY OF THE IPR'S REPRESENTED ON THE “OMA IPR DECLARATIONS” LIST, INCLUDING, BUT NOT LIMITED TO THE ACCURACY, COMPLETENESS, VALIDITY OR RELEVANCE OF THE INFORMATION OR WHETHER OR NOT SUCH RIGHTS ARE ESSENTIAL OR NON-ESSENTIAL.

THE OPEN MOBILE ALLIANCE IS NOT LIABLE FOR AND HEREBY DISCLAIMS ANY DIRECT, INDIRECT, PUNITIVE, SPECIAL, INCIDENTAL, CONSEQUENTIAL, OR EXEMPLARY DAMAGES ARISING OUT OF OR IN CONNECTION WITH THE USE OF DOCUMENTS AND THE INFORMATION CONTAINED IN THE DOCUMENTS.

© 2011 Open Mobile Alliance Ltd. All Rights Reserved.

Used with the permission of the Open Mobile Alliance Ltd. under the terms set forth above.

Contents

- 1. SCOPE4
- 2. REFERENCES5
 - 2.1 NORMATIVE REFERENCES5
 - 2.2 INFORMATIVE REFERENCES5
- 3. TERMINOLOGY AND CONVENTIONS6
 - 3.1 CONVENTIONS6
 - 3.2 DEFINITIONS6
 - 3.3 ABBREVIATIONS6
- 4. INTRODUCTION7
- 5. DPE MANAGEMENT OBJECT8
 - 5.1 MANAGEMENT OBJECT PARAMETERS8
 - 5.1.1 Node: <X>8
 - 5.1.2 Node: <X>/DPEConnectionProfile.....9
 - 5.1.3 Node: <X>/DPEConnectionProfile/ServerID9
 - 5.1.4 Node: <X>/DPEConnectionProfile/Name9
 - 5.1.5 Node: <X>/DPEConnectionProfile/NetworkPref9
 - 5.1.6 Node: <X>/DpeConnectionProfile/Proxy9
 - 5.1.7 Node: <X>/DPEConnectionProfile/APN9
 - 5.1.8 Node: <X>/DPEConnectionProfile/ServerURI9
 - 5.1.9 Node: <X>/DPEConnectionProfile/ServerURI/<X>.....9
 - 5.1.10 Node: <X>/DPEConnectionProfile/ServerURI/<X>/URI10
 - 5.1.11 Node: <X>/DPEConnectionProfile/AuthInfo10
 - 5.1.12 Node: <X>/DPEConnectionProfile/AuthInfo/<X>10
 - 5.1.13 Node: <X>/DPEConnectionProfile/AuthInfo/<X>/AuthLevel10
 - 5.1.14 Node: <X>/DPEConnectionProfile/AuthInfo/<X>/AuthType10
 - 5.1.15 Node: <X>/DPEConnectionProfile/AuthInfo/<X>/AuthName10
 - 5.1.16 Node: <X>/DPEConnectionProfile/AuthInfo/<X>/AuthSecret11
 - 5.1.17 Node: <X>/DPEConnectionProfile/AuthInfo/<X>/AuthData11
- APPENDIX A. CHANGE HISTORY (INFORMATIVE)12
 - A.1 APPROVED VERSION HISTORY12

Figures

- Figure 1 DPE MO8

1. Scope

This document defines the OMA DPE Management Object that enables management of DPE connection profiles.

2. References

2.1 Normative References

- [DPE] "Device Profile Evolution Technical Specification Version 1.0". Open Mobile Alliance™ OMA-TS-DPE-V1_0. [URL:http://www.openmobilealliance.org](http://www.openmobilealliance.org)
- [DMBOOT] "OMA Device Management Bootstrap, Version 1.2". Open Mobile Alliance™. OMA-TS-DM_Bootstrap-V1_2. [URL:http://www.openmobilealliance.org](http://www.openmobilealliance.org)
- [DMPRO] "OMA Device Management Protocol, Version 1.2". Open Mobile Alliance™ OMA-TS-DM_Protocol-V1_2. URL: <http://www.openmobilealliance.org>
- [DMSTDOBJ] "OMA Device Management Standardized Objects, Version 1.2". Open Mobile Alliance™ OMA-TS-DM-StdObj-V1_2. [URL:http://www.openmobilealliance.org](http://www.openmobilealliance.org)
- [DMTND] "OMA Device Management Tree and Description Serialization Specification, Version 1.2". Open Mobile Alliance. OMA-TS-DM_TNDS-V1_2. [URL:http://www.openmobilealliance.org](http://www.openmobilealliance.org)
- [DM-TND-V1-2] "OMA Device Management Tree and Description, Version 1.2". Open Mobile Alliance™ OMA-TS-DM_TND-V1_2 [URL:http://www.openmobilealliance.org](http://www.openmobilealliance.org)
- [GENFORM] "WAP General Formats Document", WAP Forum_, WAP-188-WAPGenFormats, [URL:http://www.openmobilealliance.org](http://www.openmobilealliance.org)
- [RFC791] "Internet Protocol", RFC 791, The Internet Society, URL:<http://www.ietf.org/rfc/rfc791.txt>
- [RFC1918] "Address Allocation for Private Internets", RFC 1918 , The Internet Society, URL:<http://www.ietf.org/rfc/rfc1918.txt>
- [RFC2373] "IP Version 6 Addressing Architecture", RFC 2373, The Internet Society, URL:<http://www.ietf.org/rfc/rfc2373.txt>
- [RFC3513] "Internet Protocol Version 6 (IPv6) Addressing Architecture", RFC 3513, The Internet Society, URL:<http://www.ietf.org/rfc/rfc3513.txt>
- [RFC3986] "URI Generic Syntax", RFC 3986, The Internet Society, URL:<http://rfc.net/rfc3986.html>
- [AUTH-RFC791] *RFC 791, Internet Protocol, DARPA, 1981, URL:http://www.ietf.org/rfc/rfc791.txt*

2.2 Informative References

- [DPEMO-DDF] "DPE Management Object Device Description Framework", URL:
<http://www.openmobilealliance.org/>

3. Terminology and Conventions

3.1 Conventions

The key words “MUST”, “MUST NOT”, “REQUIRED”, “SHALL”, “SHALL NOT”, “SHOULD”, “SHOULD NOT”, “RECOMMENDED”, “MAY”, and “OPTIONAL” in this document are to be interpreted as described in [RFC2119].

All sections and appendixes, except “Scope” and “Introduction”, are normative, unless they are explicitly indicated to be informative.

3.2 Definitions

See the DM Tree and Description [DM-TND-V1-2] document for definitions of terms related to the management tree.

3.3 Abbreviations

DM	Device Management
DPE	Device Profile Evolution
MO	Management Object
OMA	Open Mobile Alliance
SMSC	Short Message Service Centre

4. Introduction

DM group has defined Management Objects where parameters can be easily managed and used by applications. This document describes the OMA Device Profile Evolution (DPE) Management Object syntax that that enables management of default DPE connection profiles.

5. DPE Management Object

DPE Management Object (MO) is an object for OMA DPE that allows a device to present its DPE configuration in a standardized way, allowing also the subsequent retrieval and management of the DPE connection profile. The DPE connection profile is used by DPE Clients to activate DPE interfaces, e.g. setup data connections and deliver interface messages to the correct address of the DPE Server.

The OMA DPE MO is defined using the OMA DM Device Description Framework and is compatible with OMA DM protocol version 1.2 [DMPRO] or any later compatible version. If DPE MO is to be configured during initial configuration (i.e. bootstrap) then the DM Profile, as described in [DMBOOT], SHALL be used.

The Management Object Identifier is: urn:oma:mo:oma-dpe:1.0.

The following figure shows the OMA DPE Management Object.

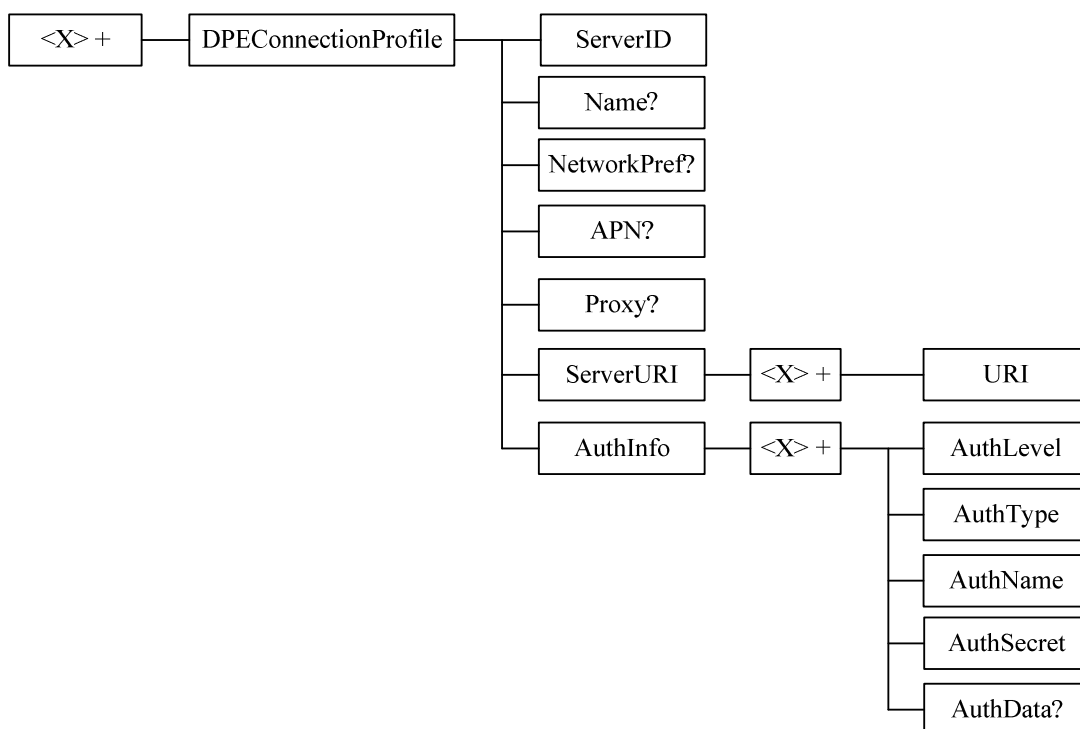

Figure 1 DPE MO

5.1 Management Object parameters

This section describes the parameters for the OMA DPE Management Object. The use of the connection profiles is defined in [DPE]. The complete Device Description Framework of this DPE management object can be found in [DPE-DDF].

5.1.1 Node: <X>

Status	Occurrence	Format	Access
REQUIRED	OneOrMore / One	Node	Get

This interior node acts as a placeholder for one or more accounts or for a fixed node.

5.1.2 Node: <X>/DPEConnectionProfile

Status	Occurrence	Format	Access
REQUIRED	One	Node	Get

This interior node specifies connection profile information applicable between the DPE Client and DPE Server.

5.1.3 Node: <X>/DPEConnectionProfile/ServerID

Status	Occurrence	Format	Access
REQUIRED	One	Chr	Get

This node specifies the unique identifier of the DPE Server, and associates the connection profile settings to a specific DPE Service Provider. The node is not used by the DPE Client for connection purposes.

5.1.4 Node: <X>/DPEConnectionProfile/Name

Status	Occurrence	Format	Access
OPTIONAL	ZeroOrOne	Chr	Get

This node specifies the user displayable name of the DPE Server.

5.1.5 Node: <X>/DPEConnectionProfile/NetworkPref

Status	Occurrence	Format	Access
OPTIONAL	ZeroOrOne	Chr	Get

This node specifies a priority-ordered list of network/bearer types for use in content delivery, selected per arbitrary deployment-specific criteria. The value is a comma-separated list, including one or more of the strings "UMTS", "WiMAX", "LTE", "802.11".

5.1.6 Node: <X>/DpeConnectionProfile/Proxy

This node specifies the address (IP address or hostname) of the WAP proxy that should be used for transactions with the DPE Server.

Status	Occurrence	Format	Access
OPTIONAL	ZeroOrOne	Chr	Get

5.1.7 Node: <X>/DPEConnectionProfile/APN

Status	Occurrence	Format	Access
OPTIONAL	ZeroOrOne	Chr	Get

This node specifies the Access Point Name used to establish a data connection for the interface.

5.1.8 Node: <X>/DPEConnectionProfile/ServerURI

Status	Occurrence	Format	Access
REQUIRED	One	Node	Get

This node specifies the (multiple) DPE Server URI(s).

5.1.9 Node: <X>/DPEConnectionProfile/ServerURI/<X>

Status	Occurrence	Format	Access
REQUIRED	OneOrMore	Node	Get

This interior node acts as a placeholder for separating one or more DPE Server URI(s).

5.1.10 Node: <X>/DPEConnectionProfile/ServerURI/<X>/URI

Status	Occurrence	Format	Access
REQUIRED	One	Chr	Get

This node is used to specify the DPE Server address, which may differ based on the used transport binding.

5.1.11 Node: <X>/DPEConnectionProfile/AuthInfo

Status	Occurrence	Format	Access
REQUIRED	One	Node	Get

This node specifies the authentication information between the DPE Client and the DPE Server.

5.1.12 Node: <X>/DPEConnectionProfile/AuthInfo/<X>

Status	Occurrence	Format	Access
REQUIRED	OneOrMore	Node	Get

This interior node acts as a placeholder for separating one or more authentication settings.

5.1.13 Node: <X>/DPEConnectionProfile/AuthInfo/<X>/AuthLevel

Status	Occurrence	Format	Access
REQUIRED	One	Chr	Get

This leaf node specifies the authentication level. The used values are described below:

Transport	Status	Description
CLCRED	Optional	Credentials which are used by the DPE Client to authenticate itself to the DPE Server, including the possible authentication schemes HTTP-BASIC, HTTP-DIGEST.
HTTP	Optional	Credentials for HTTP (/WSP) authentication. NOTE: If this AuthLevel is selected, the possible authentication schemes are HTTP-BASIC, HTTP-DIGEST and TRANSPORT. Other values are not excluded.

5.1.14 Node: <X>/DPEConnectionProfile/AuthInfo/<X>/AuthType

Status	Occurrence	Format	Access
REQUIRED	One	Chr	Get

This leaf node specifies the authentication scheme. The values could be "HTTP-BASIC", "HTTP-DIGEST", "BASIC", "MD5", "X509". Other values are not excluded.

5.1.15 Node: <X>/DPEConnectionProfile/AuthInfo/<X>/AuthName

Status	Occurrence	Format	Access
REQUIRED	One	Chr	Get

This node specifies the user name for use with digest authentication method. If the digest authentication method is specified and the value of this node is not present, the user name is to be determined through other unspecified means, e.g. user prompts.

5.1.16 Node: <X>/DPEConnectionProfile/AuthInfo/<X>/AuthSecret

Status	Occurrence	Format	Access
REQUIRED	One	Chr	Get

This node specifies the password for use with digest authentication method. If the digest authentication method is specified and the value of this node is not present, the password is to be determined through other unspecified means, e.g. user prompts.

5.1.17 Node: <X>/DPEConnectionProfile/AuthInfo/<X>/AuthData

Status	Occurrence	Format	Access
OPTIONAL	One	Chr	No Get

This node specifies the authentication data related to the authentication type, for example, digest information.

Appendix A. Change History (Informative)

A.1 Approved Version History

Reference	Date	Description
OMA-TS-DPE_MO-V1_0-20110705-A	05 Jul 2011	Status changed to Approved by TP: OMA-TP-2011-0225-INP_DPE_V1_0_ERP_for_Final_Approval