



# Firmware Update Management Object Architecture

Approved Version 1.0 – 09 Feb 2007

---

**Open Mobile Alliance**  
OMA-AD-FUMO-V1\_0-20070209-A

Use of this document is subject to all of the terms and conditions of the Use Agreement located at <http://www.openmobilealliance.org/UseAgreement.html>.

Unless this document is clearly designated as an approved specification, this document is a work in process, is not an approved Open Mobile Alliance™ specification, and is subject to revision or removal without notice.

You may use this document or any part of the document for internal or educational purposes only, provided you do not modify, edit or take out of context the information in this document in any manner. Information contained in this document may be used, at your sole risk, for any purposes. You may not use this document in any other manner without the prior written permission of the Open Mobile Alliance. The Open Mobile Alliance authorizes you to copy this document, provided that you retain all copyright and other proprietary notices contained in the original materials on any copies of the materials and that you comply strictly with these terms. This copyright permission does not constitute an endorsement of the products or services. The Open Mobile Alliance assumes no responsibility for errors or omissions in this document.

Each Open Mobile Alliance member has agreed to use reasonable endeavors to inform the Open Mobile Alliance in a timely manner of Essential IPR as it becomes aware that the Essential IPR is related to the prepared or published specification. However, the members do not have an obligation to conduct IPR searches. The declared Essential IPR is publicly available to members and non-members of the Open Mobile Alliance and may be found on the “OMA IPR Declarations” list at <http://www.openmobilealliance.org/ipr.html>. The Open Mobile Alliance has not conducted an independent IPR review of this document and the information contained herein, and makes no representations or warranties regarding third party IPR, including without limitation patents, copyrights or trade secret rights. This document may contain inventions for which you must obtain licenses from third parties before making, using or selling the inventions. Defined terms above are set forth in the schedule to the Open Mobile Alliance Application Form.

NO REPRESENTATIONS OR WARRANTIES (WHETHER EXPRESS OR IMPLIED) ARE MADE BY THE OPEN MOBILE ALLIANCE OR ANY OPEN MOBILE ALLIANCE MEMBER OR ITS AFFILIATES REGARDING ANY OF THE IPR'S REPRESENTED ON THE “OMA IPR DECLARATIONS” LIST, INCLUDING, BUT NOT LIMITED TO THE ACCURACY, COMPLETENESS, VALIDITY OR RELEVANCE OF THE INFORMATION OR WHETHER OR NOT SUCH RIGHTS ARE ESSENTIAL OR NON-ESSENTIAL.

THE OPEN MOBILE ALLIANCE IS NOT LIABLE FOR AND HEREBY DISCLAIMS ANY DIRECT, INDIRECT, PUNITIVE, SPECIAL, INCIDENTAL, CONSEQUENTIAL, OR EXEMPLARY DAMAGES ARISING OUT OF OR IN CONNECTION WITH THE USE OF DOCUMENTS AND THE INFORMATION CONTAINED IN THE DOCUMENTS.

© 2007 Open Mobile Alliance Ltd. All Rights Reserved.

Used with the permission of the Open Mobile Alliance Ltd. under the terms set forth above.

# Contents

- 1. SCOPE (INFORMATIVE) .....4
- 2. REFERENCES .....5
  - 2.1 NORMATIVE REFERENCES .....5
  - 2.2 INFORMATIVE REFERENCES .....5
- 3. TERMINOLOGY AND CONVENTIONS .....6
  - 3.1 CONVENTIONS .....6
  - 3.2 DEFINITIONS .....6
  - 3.3 ABBREVIATIONS .....6
- 4. INTRODUCTION (INFORMATIVE) .....7
  - 4.1 USE CASE .....7
  - 4.2 REQUIREMENTS .....7
  - 4.3 PLANNED PHASES .....7
- 5. ARCHITECTURAL MODEL .....8
  - 5.1 DEPENDENCIES .....8
  - 5.2 ARCHITECTURAL DIAGRAM .....8
  - 5.3 FUNCTIONAL COMPONENTS AND INTERFACES .....8
    - 5.3.1 The FUMO Enabler .....9
    - 5.3.2 The DM Client Component .....9
    - 5.3.3 The Alternate Download Client component in the device .....9
    - 5.3.4 The DM Server component .....9
    - 5.3.5 The Interface FUMO-1 .....9
  - 5.4 FLOWS .....9
    - 5.4.1 OMA DM Download of an Update Package .....9
    - 5.4.2 Download of an Update Package over Alternate Download Mechanisms .....10
    - 5.4.3 Server Initiating Update Activity with Device already has an Update Package .....12
    - 5.4.4 Server Initiating Combined Download and Update Activity .....12
    - 5.4.5 Client Initiated Firmware Update .....13
- APPENDIX A. CHANGE HISTORY (INFORMATIVE) .....15
  - A.1 APPROVED VERSION HISTORY .....15

# Figures

- Figure 1: Diagram of FUMO Architecture .....8
- Figure 2: OMA DM Download of an Update Package .....10
- Figure 3: Alternate Download of an Update Package .....11
- Figure 4: OMA DL Download of an Update Package .....11
- Figure 5: Alternate download and Update of an Update Firmware Package .....13

# 1. Scope

**(Informative)**

The scope of this document is the architecture for the Firmware Update Management Object (FUMO) specifications. In general, the scope includes the DM server environment, download mechanisms and devices.

## 2. References

### 2.1 Normative References

- [DLOTA] “Generic Content Download Over The Air Specification Version 1.0”, Open Mobile Alliance™, OMA-Download-OTA-v1\_0, URL: <http://www.openmobilealliance.org/>
- [DMPRO] “OMA Device Management Protocol, Version 1.2”. Open Mobile Alliance™. OMA-TS-DM-Protocol-V1\_2.  
URL: <http://www.openmobilealliance.org>
- [DMRD] “OMA Device Management Requirements Document, Version 1.2”. Open Mobile Alliance™. OMA-RD-DM-V1\_2.  
URL: <http://www.openmobilealliance.org>
- [DMSTDOBJ] “OMA Device Management Standardized Objects, Version 1.2”. Open Mobile Alliance™. OMA-TS-DM-StdObj-V1\_2.  
URL: <http://www.openmobilealliance.org>
- [RFC2119] “Key words for use in RFCs to Indicate Requirement Levels”, S. Bradner, March 1997,  
URL: <http://www.ietf.org/rfc/rfc2119.txt>

### 2.2 Informative References

None.

## 3. Terminology and Conventions

### 3.1 Conventions

The key words “MUST”, “MUST NOT”, “REQUIRED”, “SHALL”, “SHALL NOT”, “SHOULD”, “SHOULD NOT”, “RECOMMENDED”, “MAY”, and “OPTIONAL” in this document are to be interpreted as described in [Error! Reference source not found.].

All sections and appendixes, except “Scope” and “Introduction”, are normative, unless they are explicitly indicated to be informative.

This is an informative document, which is not intended to provide testable requirements to implementations.

### 3.2 Definitions

<b>Firmware Update</b>	An activity that results in updating the firmware of the device using an update package.
<b>Update Package</b>	A file comprising difference information that can be used to update the firmware of the device from one version to another.

### 3.3 Abbreviations

<b>DLOTA</b>	Download Over The Air
<b>DMWSI</b>	Device Management Web Services Interface
<b>FUMO</b>	Firmware Update Management Object
<b>OMA</b>	Open Mobile Alliance
<b>SC</b>	Smartcard

## 4. Introduction

**(Informative)**

Firmware update activities comprise interactions between a device, a DM server and, optionally, a download server. It may be initiated by a user, the device, or the server. A management tree object, the Firmware Update Management Object (FUMO) [DMTND] defined for firmware updates is used for setting up parameters and update packages necessary for conducting a firmware update.

### 4.1 Use Case

Please refer to the [DMRD] for the relevant use-case (Non-application Software Download).

### 4.2 Requirements

- a) The firmware update architecture SHALL support the following activities in order to achieve a firmware update:
  - 1. Firmware Update Initiation
  - 2. Device Information Exchange
  - 3. Update Package Download
  - 4. Update Package Installation
  - 5. Notification of Firmware Update
- b) The device MUST be capable of either large object downloads [DMPRO] or an alternate download mechanism.
- c) The DM client in the device MUST be capable of supporting a firmware update management object (FUMO).
- d) The DM server MUST be able to manage the FUMO in the device.

### 4.3 Planned Phases

The FUMO specification 1.0 implements all the requirements enumerated above.

## 5. Architectural Model

### 5.1 Dependencies

The firmware update architecture diagram indicates dependencies on the OMA DM architecture. It also optionally depends on an alternate download mechanism, such as OMA Download [DLOTA] architecture.

### 5.2 Architectural Diagram

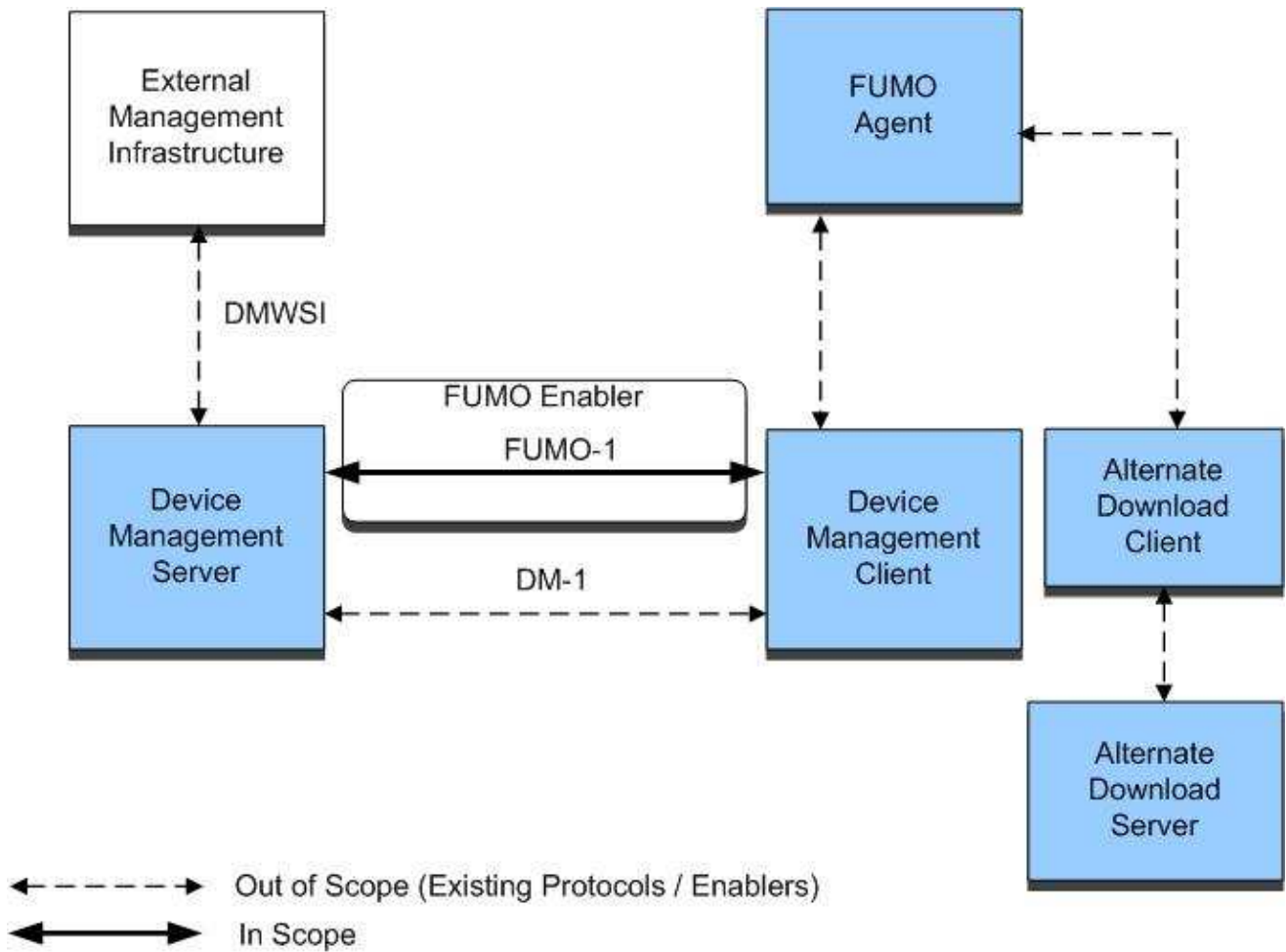

Figure 1: Diagram of FUMO Architecture

### 5.3 Functional Components and Interfaces



### 5.3.1 The FUMO Enabler

The FUMO Enabler provides a firmware update management object (FUMO) for firmware updates that the DM Client provides access to, such that the DM server can manipulate it. The DM Client makes it possible to initiate firmware updates in the device via the firmware update management object.

#### 5.3.1.1 The FUMO Agent Component

The FUMO agent function is responsible for the update activity. It consumes the update package delivered to the device by the OMA DM client or an alternate download client in the device. It is expected to communicate a success or failure result to the DM client at the termination of the update activity, for communication back to the DM server.

### 5.3.2 The DM Client Component

The DM client component makes it possible for the DM Server to manage the device using the DM-1 protocol. For firmware updates, the DM server and the DM client interact over the FUMO-1 interface as well.

#### 5.3.2.1 The Large Object Download function of the DM Client

The large object download function is an optional feature of the DM Client that makes it possible to download update packages using the OMA-DM protocol [DMPRO].

### 5.3.3 The Alternate Download Client component in the device

The alternate download client component is an optional feature of the device that makes it possible to download update packages using the alternate download mechanism, such as DLOTA. The interaction of the FUMO agent with the Download client is out of scope.

### 5.3.4 The DM Server component

The DM server component supports device discovery, determination of an appropriate update package and delivery of an update package to the device over Large Object downloads (if the device can support that), all over the DM-1 interface. It also receives a firmware update specific notification from the DM Client, employing the Generic Alert mechanism, comprising results for an activity (update or download or both) invoked over the FUMO-1 interface.

### 5.3.5 The Interface FUMO-1

The interface FUMO-1 describes interactions between the DM Server and the DM Client in setting up the DM sessions, delivering update packages, and communicating results for the update activities invoked, using Generic Alerts. It is also used to setup parameters for alternate download mechanism.

## 5.4 Flows

### 5.4.1 OMA DM Download of an Update Package

*This flow describes the interaction between device and the DM server wherein the DM server delivers an update package over the OMA-DM protocols to the device.*

#### 5.4.1.1 Firmware Update via OMA DM Download (Replace)

The following architectural diagram shows how OMA DM is used directly to move a firmware update package to the device using a DM “Replace” command to access a management object representing the actual firmware binary package data:

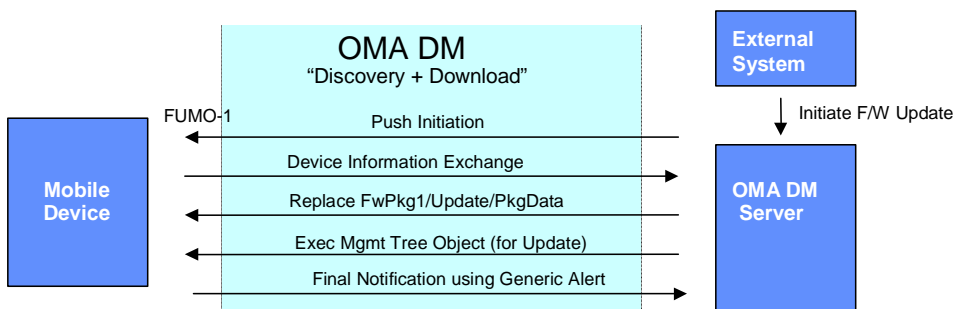

**Figure 2: OMA DM Download of an Update Package**

#### 5.4.1.2 Normal Flow

1. The DM server initiates a session with the device.
2. The device provides DevInfo [DMSTDOBJ] information to the DM server.
3. The DM server determines an appropriate update package for delivery.
4. The DM server delivers the update package over large object download. A Replace command is sent to the device to replace an update package under the /x/Update/PkgData leaf node.
5. The device acknowledges the receipt of the update package.

#### 5.4.1.3 Alternative Flow - 1

In the step 1, the device initiates a session with the DM server to request an update package for a firmware update.

#### 5.4.1.4 Alternative Flow - 2

In the step 2, DM server optionally retrieves the DevDetail [DMSTDOBJ] to determine an appropriate update package.

### 5.4.2 Download of an Update Package over Alternate Download Mechanisms

*This flow describes the interaction between device and the DM server wherein the DM server delivers an update package over alternate download mechanisms to the device.*

#### 5.4.2.1 Firmware Update through an Alternative Download Mechanism

The following architectural diagram shows how OMA DM is used to invoke an alternate download method, using a DM “Replace” command to specify the URL of the update package:

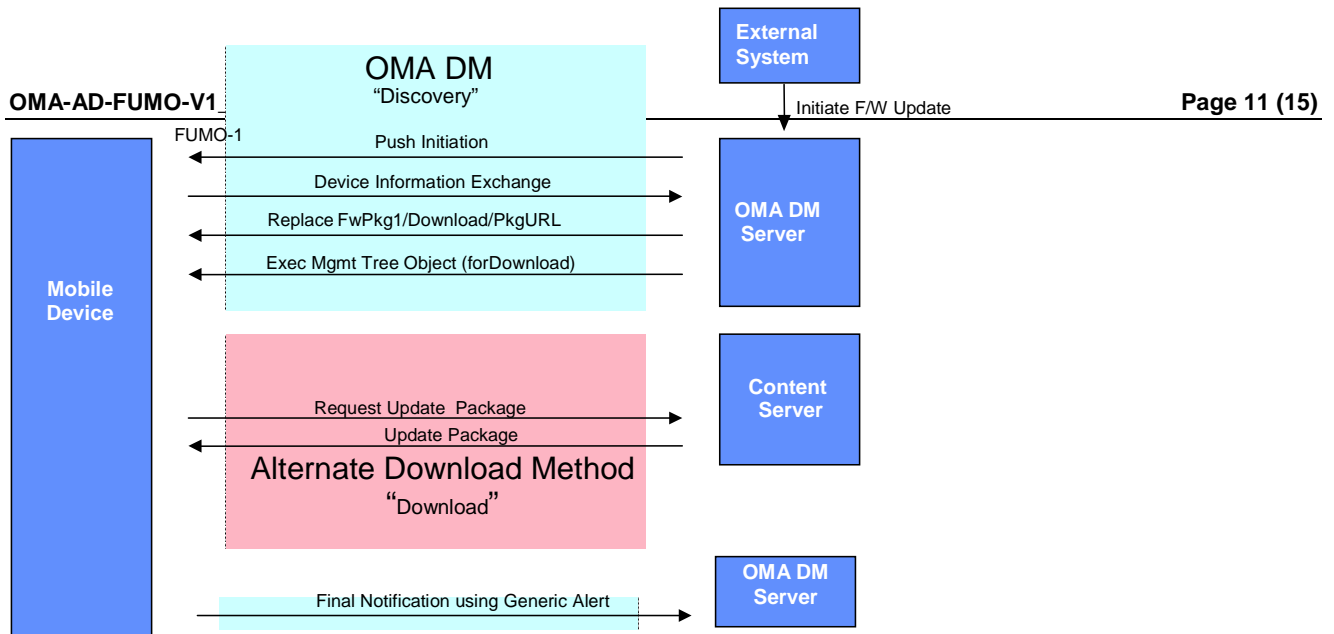

**Figure 3: Alternate Download of an Update Package**

#### 5.4.2.1.1 Update Package Download via OMA DL Method

The following architectural diagram shows how OMA DM is used to invoke an OMA DL download method [DLOTA], using a DM “Replace” command to specify the URL of the download descriptor that describes further details concerning the firmware update package and the download method to be used:

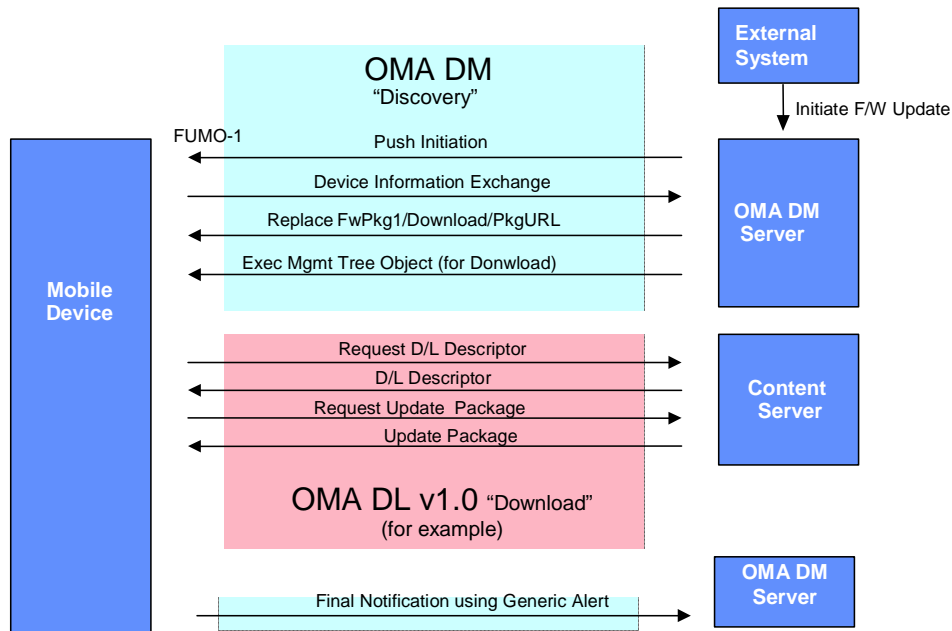

**Figure 4: OMA DL Download of an Update Package**

### 5.4.2.2 Normal Flow

1. The DM server initiates a session with the device.
2. The device provides DevInfo information to the DM server.
3. The DM server determines an appropriate update package for delivery.
4. The DM server determines an appropriate alternate download mechanism.
5. The DM Server sets the PkgURL element under the /x/Download node.
6. The DM Server sends to the Device an Exec command targeting /x/Download node.
7. The device retrieves the update package using the alternate download mechanism.
8. The device acknowledges the receipt of the update package.

### 5.4.2.3 Alternative Flow - 1

In the step 3, DM server optionally retrieves the DevDetail to determine an appropriate update package.

## 5.4.3 Server Initiating Update Activity with Device already has an Update Package

*This flow describes the interaction between device and the DM server wherein the DM server initiates an update activity on the device*

### 5.4.3.1 Normal Flow

1. [Optional] The Network Operations / Service provider provides a request to DM server for invoking an update on a device.
2. The DM server initiates a session with the device.
3. The DM server instructs the device to start an update using an Exec command on the Update node.
4. The device initiates an update activity.
5. The device completes the update activity and reports results to the DM server.

### 5.4.3.2 Alternative Flow - 1

In the step 1, the device initiates an update activity.

## 5.4.4 Server Initiating Combined Download and Update Activity

*This flow describes the interaction between device and the DM server wherein the DM server initiates a combined download and update activity on the device*

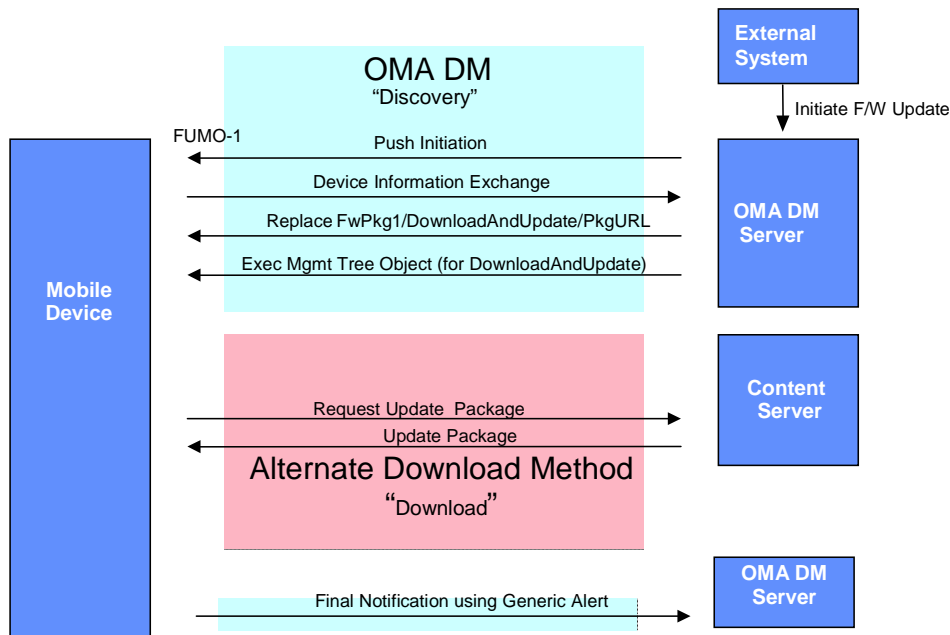

Figure 5: Alternate Download and Update of an Update Firmware Package

#### 5.4.4.1 Normal Flow

1. [Optional] The Network Operations / Service provider provides a request to DM server for invoking an update on a device.
2. The DM server initiates a session with the device.
3. The DM server instructs the device to start a download from a PkgURL parameter provided, and then start an update. It uses an Exec command on the /x/DownloadAndUpdate node.
4. The device initiates a download activity followed by an update activity.
5. The device completes the update activity and reports results to the DM server.

#### 5.4.4.2 Alternative Flow - 1

In the step 1, the device initiates an update activity.

### 5.4.5 Client Initiated Firmware Update

*This flow describes the interaction between device and the DM server wherein the DM client initiates a firmware update activity on the device*

#### 5.4.5.1 Normal Flow

1. The DM client in device initiates a session with the DM server and communicates a Generic Alert with the right Alert type.

3. The DM server, based on the Alert type received, instructs the device to start a download (from a PkgURL for example) provided, and then to immediately start an update. It uses an Exec command on the /x/DownloadAndUpdate node, based on the client-initiated Alert type.
4. The device downloads an update package and then initiates a firmware update, immediately.
5. The device completes the update activity and reports results to the DM server.

#### **5.4.5.2 Alternative Flow - 1**

In the step 3, the device initiates a download activity when it receives an Exec command on a /x/Downlaod node. It then waits for the next Exec command on the /x/Update node before starting the update.

#### **5.4.5.3 Alternative Flow - 2**

In the step 3, the device initates a download activity when it receives a Replace command on /x/Update/PkgData leaf node. It then waits for an Exec command on a /x/Update node to starts an update.

## Appendix A. Change History

(Informative)

### A.1 Approved Version History

Reference	Date	Description
OMA-AD-FUMO-V1_0	09 Feb 2007	Status changed to Approved by TP TP Doc ref# OMA-TP-2007-0076R01- INP_ERP_FUMO_V1.0_for_Final_Approval