



General Service Subscription Management Requirements

Candidate Version 1.0 – 22 Oct 2009

Open Mobile Alliance
OMA-RD-GSSM-V1_0-20091022-C

Use of this document is subject to all of the terms and conditions of the Use Agreement located at <http://www.openmobilealliance.org/UseAgreement.html>.

Unless this document is clearly designated as an approved specification, this document is a work in process, is not an approved Open Mobile Alliance™ specification, and is subject to revision or removal without notice.

You may use this document or any part of the document for internal or educational purposes only, provided you do not modify, edit or take out of context the information in this document in any manner. Information contained in this document may be used, at your sole risk, for any purposes. You may not use this document in any other manner without the prior written permission of the Open Mobile Alliance. The Open Mobile Alliance authorizes you to copy this document, provided that you retain all copyright and other proprietary notices contained in the original materials on any copies of the materials and that you comply strictly with these terms. This copyright permission does not constitute an endorsement of the products or services. The Open Mobile Alliance assumes no responsibility for errors or omissions in this document.

Each Open Mobile Alliance member has agreed to use reasonable endeavours to inform the Open Mobile Alliance in a timely manner of Essential IPR as it becomes aware that the Essential IPR is related to the prepared or published specification. However, the members do not have an obligation to conduct IPR searches. The declared Essential IPR is publicly available to members and non-members of the Open Mobile Alliance and may be found on the “OMA IPR Declarations” list at <http://www.openmobilealliance.org/ipr.html>. The Open Mobile Alliance has not conducted an independent IPR review of this document and the information contained herein, and makes no representations or warranties regarding third party IPR, including without limitation patents, copyrights or trade secret rights. This document may contain inventions for which you must obtain licenses from third parties before making, using or selling the inventions. Defined terms above are set forth in the schedule to the Open Mobile Alliance Application Form.

NO REPRESENTATIONS OR WARRANTIES (WHETHER EXPRESS OR IMPLIED) ARE MADE BY THE OPEN MOBILE ALLIANCE OR ANY OPEN MOBILE ALLIANCE MEMBER OR ITS AFFILIATES REGARDING ANY OF THE IPR'S REPRESENTED ON THE “OMA IPR DECLARATIONS” LIST, INCLUDING, BUT NOT LIMITED TO THE ACCURACY, COMPLETENESS, VALIDITY OR RELEVANCE OF THE INFORMATION OR WHETHER OR NOT SUCH RIGHTS ARE ESSENTIAL OR NON-ESSENTIAL.

THE OPEN MOBILE ALLIANCE IS NOT LIABLE FOR AND HEREBY DISCLAIMS ANY DIRECT, INDIRECT, PUNITIVE, SPECIAL, INCIDENTAL, CONSEQUENTIAL, OR EXEMPLARY DAMAGES ARISING OUT OF OR IN CONNECTION WITH THE USE OF DOCUMENTS AND THE INFORMATION CONTAINED IN THE DOCUMENTS.

© 2009 Open Mobile Alliance Ltd. All Rights Reserved.

Used with the permission of the Open Mobile Alliance Ltd. under the terms set forth above.

Contents

1. SCOPE (INFORMATIVE)	7
2. REFERENCES	8
2.1 NORMATIVE REFERENCES.....	8
2.2 INFORMATIVE REFERENCES.....	8
3. TERMINOLOGY AND CONVENTIONS.....	9
3.1 CONVENTIONS.....	9
3.2 DEFINITIONS.....	9
3.3 ABBREVIATIONS.....	9
4. INTRODUCTION (INFORMATIVE).....	11
4.1 SERVICE SUBSCRIPTION CONCEPT IN OMA.....	11
4.2 ACTORS IN THE CONTEXT OF GSSM.....	12
4.3 RELATIONSHIP BETWEEN SUBSCRIPTION PROFILE AND SERVICE PREFERENCES.....	12
5. GSSM RELEASE DESCRIPTION (INFORMATIVE).....	14
5.1 VERSION 1.0.....	14
6. REQUIREMENTS (NORMATIVE).....	15
6.1 HIGH-LEVEL FUNCTIONAL REQUIREMENTS.....	15
6.1.1 Service Subscription Operations.....	15
6.1.2 Subscription Validation Operations.....	16
6.1.3 Provisioning Related Operations.....	16
6.1.4 Security.....	17
6.1.5 Charging.....	18
6.1.6 Administration and Configuration.....	18
6.1.7 Privacy.....	18
6.2 OVERALL SYSTEM REQUIREMENTS.....	18
APPENDIX A. CHANGE HISTORY (INFORMATIVE).....	19
A.1 APPROVED VERSION HISTORY.....	19
A.2 DRAFT/CANDIDATE VERSION 1.0 HISTORY.....	19
APPENDIX B. USE CASES (INFORMATIVE).....	21
B.1 SERVICE SUBSCRIPTION FOR DIGITAL NEWSPAPER SERVICE.....	21
B.1.1 Short Description.....	21
B.1.2 Actors.....	21
B.1.2.1 Actor Specific Issues.....	21
B.1.2.2 Actor Specific Benefits.....	21
B.1.3 Pre-conditions.....	22
B.1.4 Post-conditions.....	22
B.1.5 Normal Flow.....	22
B.1.6 Alternative Flow 1: Subscription with Subscriber's Confirmation.....	23
B.1.7 Alternative Flow 2: Subscription with Notification to the Subscriber.....	24
B.1.8 Alternative Flow 3: Subscription from CP.....	25
B.1.9 Alternative Flow 4: Unsubscribe.....	25
B.1.10 Alternative Flow 5: Validation Against Business Support Systems and Final Notification.....	26
B.1.11 Operational and Quality of Experience Requirements.....	26
B.2 SERVICE SUBSCRIPTION VALIDATION FOR INDIE MUSIC BUNDLE.....	27
B.2.1 Short Description.....	27
B.2.2 Actors.....	27
B.2.2.1 Actor Specific Issues.....	27
B.2.2.2 Actor Specific Benefits.....	27
B.2.3 Pre-conditions.....	28
B.2.4 Post-conditions.....	28

- B.2.5 Normal Flow 28
- B.2.6 Alternative Flow 1: Subscriber Service Level Violation 29
- B.2.7 Alternative Flow 2: Content Provider Service Level Violation 29
- B.2.8 Operational and Quality of Experience Requirements 30
- B.3 SERVICE SUBSCRIPTION FOR GROUPS 30**
- B.3.1 Short Description 30
- B.3.2 Actors 30
- B.3.2.1 Actor Specific Issues 30
- B.3.2.2 Actor Specific Benefits 30
- B.3.3 Pre-conditions 31
- B.3.4 Post-conditions 31
- B.3.5 Normal Flow 31
- B.3.6 Operational and Quality of Experience Requirements 32
- B.4 SERVICE VALIDATION FOR A GROUP 32**
- B.4.1 Short Description 32
- B.4.2 Actors 32
- B.4.2.1 Actor Specific Issues 32
- B.4.2.2 Actor Specific Benefits 32
- B.4.3 Pre-conditions 32
- B.4.4 Post-conditions 33
- B.4.5 Normal Flow 33
- B.4.6 Alternative Flow: Subscription Preference Violation 34
- B.4.7 Operational and Quality of Experience Requirements 34
- B.5 MULTI-ENABLER-BASED SERVICE: DIGITAL PETS 34**
- B.5.1 Short Description 34
- B.5.2 Actors 34
- B.5.2.1 Actor Specific Issues 34
- B.5.2.2 Actor Specific Benefits 35
- B.5.3 Pre-conditions 35
- B.5.4 Post-conditions 35
- B.5.5 Normal Flow 36
- B.5.6 Alternative Flow 1: Subscription Absence 37
- B.5.7 Alternative Flow 2: Criteria of Subscription Invalid 38
- B.6 CHARGING FOR SERVICE SUBSCRIPTION 38**
- B.6.1 Short Description 38
- B.6.2 Actors 38
- B.6.3 Pre-conditions 38
- B.6.4 Post-conditions 38
- B.6.5 Normal Flow 39
- B.6.6 Alternative Flow: No Service Portal 39
- B.7 CHARGING ON SUBSCRIPTION VALIDATION 40**
- B.7.1 Short Description 40
- B.7.2 Actors 40
- B.7.3 Pre-conditions 40
- B.7.4 Post-conditions 40
- B.7.5 Normal Flow 40
- B.8 CONTENT-BASED SERVICE: THE CHOICE IS UP 2U 41**
- B.8.1 Short Description 41
- B.8.2 Actors 41
- B.8.2.1 Actor Specific Issues 41
- B.8.2.2 Actor Specific Benefits 41
- B.8.3 Pre-conditions 42
- B.8.4 Post-conditions 42
- B.8.5 Normal Flow 42
- B.8.6 Alternative Flow 1: Service Component Initiated Push Service 43
- B.8.7 Alternative Flow 2: Subscription Validation Fails 44
- B.9 SUBSCRIPTION MANAGEMENT FOR ON-REQUEST SERVICE: STOCK QUOTATION LIVE 44**

- B.9.1 Short Description 44
- B.9.2 Actors..... 44
- B.9.2.1 Actor Specific Issues..... 45
- B.9.2.2 Actor Specific Benefits 45
- B.9.3 Pre-conditions 45
- B.9.4 Post-conditions..... 45
- B.9.5 Normal Flow 45
- B.9.6 Alternative Flow 1: Subscription Invalid..... 46
- B.9.7 Alternative Flow 2: BeijingMobileInfo.com Sends an Unsolicited Message 46
- B.10 SERVICE SUBSCRIPTION FOR ANONYMOUS USERS..... 46**
- B.10.1 Short Description 46
- B.10.2 Actors..... 46
- B.10.2.1 Actor Specific Issues..... 46
- B.10.2.2 Actor Specific Benefits 47
- B.10.3 Pre-conditions 47
- B.10.4 Post-conditions..... 47
- B.10.5 Normal Flow: Subscription for an Anonymous User..... 48
- B.10.6 Normal Flow: Validation for an Anonymous User..... 49
- B.10.7 Alternative Flow: Validation for an Anonymous User 50
- B.10.8 Operational and Quality of Experience Requirements..... 50
- APPENDIX C. (INFORMATIVE)..... 51**
- C.1 COMPATIBILITY WITH THE SERVICE SUBSCRIPTION DATA MODELS WIDELY USED BY OSS/BSS SYSTEMS, AND IN PARTICULAR THE ONES DEFINED BY TELEMANAGEMENT FORUM (SID)..... 51**
- C.2 COMPATIBILITY WITH THE USER PROFILE AND SUBSCRIPTION MANAGEMENT MODELS SPECIFIED BY 3GPP AND ETSI TISPAN..... 52**

Figures

- Figure 1: Actor Relationship 12
- Figure 2: Relationship between Subscription Profile and Service Preferences..... 13
- Figure 4: Service Subscription for "Digital Newspaper Service" (Normal Flow) 22
- Figure 5: Service Subscription for "Digital Newspaper Service" (Alternative Flow 1) 23
- Figure 6: Service Subscription for "Digital Newspaper Service" (Alternative Flow 2) 24
- Figure 7: Service Subscription for "Digital Newspaper Service" (Alternative Flow 3) 25
- Figure 8: Unsubscribe to "Digital Newspaper Service" (Alternative Flow 4)..... 25
- Figure 9: Validation Against BSS and Final Notification for "Digital Newspaper Service" (Alternative Flow 5) 26
- Figure 10: Subscription Validation for "Indie Music Bundle" (Normal Flow) 28
- Figure 11: Subscription Validation for "Indie Music Bundle" (Alternative Flow 1) 29
- Figure 12: Subscription Validation for "Indie Music Bundle" (Alternative Flow 2) 29
- Figure 13: Service Subscription for a Group (Normal Flow) 31
- Figure 14: Service Validation for a Group (Normal Flow) 33
- Figure 15: Service Validation for a Group (Alternative Flow)..... 34
- Figure 16: Subscription Validation for "Digital Pets" Service (Normal Flow 1) 36
- Figure 17: Subscription Validation for "Digital Pets" Service (Normal Flow 2) 36

Figure 18: Subscription Validation for “Digital Pets” Service (Alternative Flow 1)37

Figure 19: Subscription Validation for “Digital Pets” Service (Alternative Flow 2)38

Figure 20: Charging for Service Subscription (Normal Flow)39

Figure 21: Charging For Service Subscription (Alternative Flow)39

Figure 22: Subscription Validation for "Blue Dog Records" (Normal Flow)40

Figure 23: Subscription for Content of a Service (Normal Flow 1).....42

Figure 24: Using the Subscribed Content of the Service (Normal Flow 2)43

Figure 25: Using the Subscribed Content of the Service (Alternative Flow 1).....43

Figure 26: Subscription Validation for a Service (Alternative Flow).....44

Figure 27: Service Subscription for an Anonymous User (Normal Flow)48

Figure 28: Service Validation for an Anonymous User (Normal Flow)49

Figure 29: Service Validation for an Anonymous User (Alternative Flow).....50

Figure 30: Key entities in the GSSM context51

Figure 31: Functional entities and actors in 3GPP SuM53

Figure 32: GUP Reference architecture.....54

Tables

Table 1: High-Level Functional Requirements 15

Table 2: High-Level Functional Requirements – Service Subscription Operations 16

Table 3: High-Level Functional Requirements – Subscription Validation Operations..... 16

Table 4: High-Level Functional Requirements – Provisioning Related Operations..... 16

Table 5: High-Level Functional Requirements – Security Items17

Table 6: High-Level Functional Requirements – Authentication Items 17

Table 7: High-Level Functional Requirements – Authorization Items 17

Table 8: High-Level Functional Requirements – Data Integrity Items 17

Table 9: High-Level Functional Requirements – Confidentiality Items 18

Table 10: High-Level Functional Requirements – Administration and Configuration Items 18

Table 11: High-Level Functional Requirements – Privacy Items..... 18

Table 12: High-Level System Requirements 18

1. Scope

(Informative)

The scope of this document is to collect use cases and requirements for service subscription management for value added services. The focus is on the functional requirements for service subscription management that are generic to all OMA service enablers and which could be re-used by those enablers which require subscription management functions.

2. References

2.1 Normative References

- [OMA-DICT] “Dictionary for OMA Specifications”, Open Mobile Alliance™, OMA-ORG-Dictionary-V2_3
URL: <http://www.openmobilealliance.org>
- [OSPE-RD] “OMA Service Provider Environment Requirements”, Open Mobile Alliance,
OMA-RD_OSPE-V1_0, URL: <http://www.openmobilealliance.org/>
- [RFC2119] “Key words for use in RFCs to Indicate Requirement Levels”, S. Bradner, March 1997, URL:
<http://www.ietf.org/rfc/rfc2119.txt>

2.2 Informative References

- [TMF GB922v6] TMF GB922 “NGOSS SID Business View Concepts” Release 6.0
URL: <http://www.tmforum.org>
- [3GPP TS 32.141] 3GPP TS 32.141, Telecommunication management; Subscription Management (SuM)
architecture
URL: <http://www.3gpp.org/ftp/specs/>
- [OMA-CHARGING] “Charging Requirements. Candidate Version 1.0 – 18 Nov 2004”, Open Mobile Alliance™,
OMA-RD_Charging-V1_0-20041118-C. URL: <http://www.openmobilealliance.org/>

3. Terminology and Conventions

3.1 Conventions

The key words “MUST”, “MUST NOT”, “REQUIRED”, “SHALL”, “SHALL NOT”, “SHOULD”, “SHOULD NOT”, “RECOMMENDED”, “MAY”, and “OPTIONAL” in this document are to be interpreted as described in [RFC2119].

All sections and appendixes, except “Scope” and “Introduction”, are normative, unless they are explicitly indicated to be informative.

3.2 Definitions

Charging	See [OMA-DICT]
Charging Account	See [OMA-DICT]
Content	See [OMA-DICT]
Content Provider	A source for the content to the end user or to the Service Provider.
Network Operator	See [OMA-DICT]
Principal	See [OMA-DICT]
Portal	See [OMA-DICT]
Resource	See [OMA-DICT]
Service	See [OMA-DICT]
Service Provider	An entity that provides and administers Service to a Subscriber and / or User. The Service Provider may or may not be the provider of the network and content.
Service Subscription Provisioning	Process that includes all the steps needed in order to fulfil a service subscription request from a principal. E.g. the process may include the following steps: provisioning of some information in the end user profile (traditional settings in the HLR), provisioning of some user information and preferences into the service platforms (in “restaurant finder service”, I like to get spanish restaurants), settings in the charging rules for the user, setting for policies to allow request for the pair user/service, etc. See [OSPE-RD].
Session	A series of interactions between two communication end points that occur during the span of a single connection or service delivery. See [OMA-CHARGING]
Session Charging	Method performing subsequent charging requests during delivery of a service. See [OMA-CHARGING]
Subscriber	See [OMA-DICT]
Subscription	See [OMA-DICT]
Subscription Preferences	Contains the service preferences chosen for a user. Each user configures his preferences for a particular subscribed service, but only within the limits defined by the Subscription. See [3GPP TS 32.141].
Subscription Profile	The set of information required for describing a service subscription, e.g. the subscriber identity, subscribed service, service preferences and/or service usage constraints.
Subscription Validation	Subscription validation is the process of checking for the existence of a subscription and evaluating that the service delivery request is within the limits defined by the Subscription Profile prior to service delivery.
User	A principal who uses services or content.

3.3 Abbreviations

BSS	Business Support System
CP	Content Provider
GSSM	General Service Subscription Management

GUP	Generic User Profile
IM	Instant Messaging
MCC	Mobile Commerce and Charging
MMS	Multimedia Messaging System
MSISDN	Mobile Subscriber Integrated Services Digital Network Number
NGOSS	New Generation Operations Systems and Software
OMA	Open Mobile Alliance
OSE	Open Service Environment
OSS	Operations Support System
PoC	Push-to-talk over Cellular
RAF	Repository Access Function
SID	Shared Information/Data
SMS	Short Message System
SP	Service Provider
SuM	Subscription Management
WAP	Wireless Application Protocol

4. Introduction (Informative)

The objective of this document is to capture the uses cases relevant to service subscription management and then specify the functional requirements derived from these use cases. The subscriber is allowed to setup, terminate, change, query his/her subscriptions by actions such as subscribing and unsubscribing services, registering authorized user(s) for using the service, and setting subscription preferences and/or service usage constraints for associated users(s). The benefit of making these requirements generic for all OMA enablers are:

- Reduced cost and complexity: each service enabler/application server have one common way of handling service subscription management.
- Improved usability: consolidate varying subscription flows and requirements for subscribing different services, and provide the ability to express cross-application subscription preferences.
- Reduced management complexity: simplified design for management of service subscription information for different services since they have one common way of accessing service subscription information.

The GSSM RD aims to specify the requirements for a general service subscription management function in compliance with the horizontal services concept of the OMA Services Environment (OSE), which is expected to cover management of all services subscriptions within the operator or service provider's domain and thus avoid the unnecessary complexity of a silo approach to subscription management.

Examples of such functions include:

- Service subscription handling
 - Subscribe or Unsubscribe
 - Subscription suspension/resume/renewal
 - Subscription query
- Service subscription validation
 - Checking the existence of service subscription for any service requests
 - Checking wither the service request complies with subscription parameters set in service subscription profile
- Service subscription notification and confirmation
 - Notifying the change of service subscription to related entities
 - Informing/confirming subscribers about subscription changes

This RD makes no assumption on the service subscription information location; the focus is primarily on the means to access such data for provisioning purpose, viewing purpose, etc.

4.1 Service Subscription Concept in OMA

Service subscription describes the commercial relationship between the subscriber and operator/service provider. Service subscription is essential for operators and service providers, since at least the following actions would pertain to service subscription information:

- New Service Subscription: by checking if a principal is permitted to subscribe to a service;
- Subscription validation: by checking if a principal is subscribed to a service, operator/service provider can control if the principal is allowed to access a service (subscriber-initiated service), or if the service application is allowed to push a content to a principal (application-initiated service);
- Charging: Subscription management operations may impact the details of related chargeable events.
- Service Delivery: depending on the service provider choices, some service customizations or preferences might be included in the service subscription information, and this would be needed in service delivery time, e.g.: preferred notification methods, time of delivery, service parameters, etc.

Service subscription includes (among other pieces of information like service customization and other subscription parameters) the subscribed service(s) that are available to a principal (e.g., if the principal is subscribed to a WAP-based “mobile weather forecast” service).

The GSSM RD aims to specify functions which decouple access to service subscription from its actual representation and the location of the information by providing:

- A single point of access to service subscription functions across multiple instances of a service (e.g. multiple PoC servers)
- A common interface to service subscription functions across multiple services (e.g. PoC, IM, etc.).

4.2 Actors in the Context of GSSM

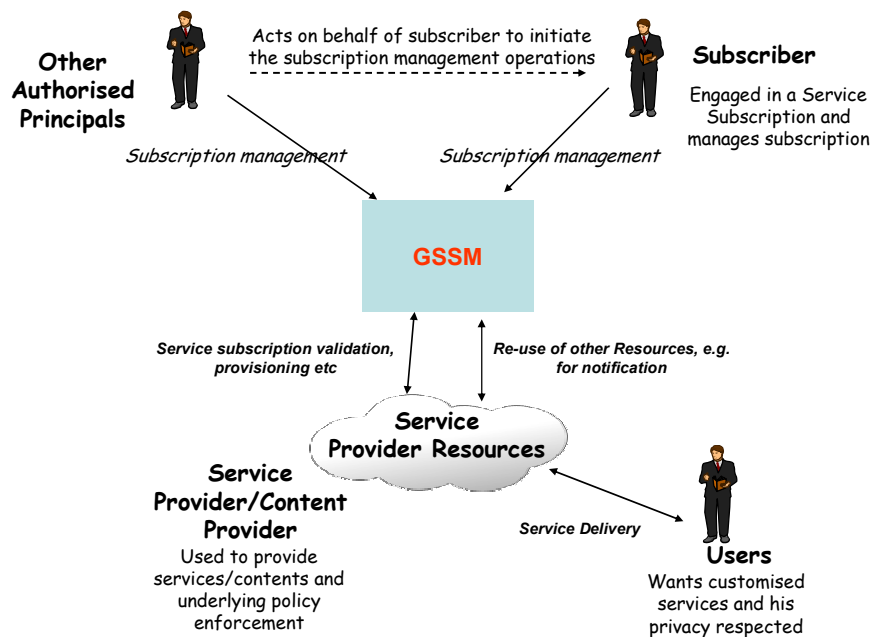

Figure 1: Actor Relationship

The **Subscriber** is the authorised principal that is engaged in a subscription (commercial relationship) with a **Service Provider/Content Provider** for the delivery of value added services or content to **User(s)**. The User is any principal, (usually a human end-user) who consumes the service whose subscription is being managed by GSSM.

The Subscriber acts on behalf of the User and is responsible for managing (provision, modify etc) the service subscription and for payment of the services delivered to and consumed by the User. The Subscriber may or may not be the same principal as the User.

There may also be other **Authorised Principals** who may perform subscription management operations for the Subscriber.

4.3 Relationship Between Subscription Profile and Service Preferences

The Service Preferences describe all information that is possible to adapt for a specific User without taking any subscription aspects in consideration, i.e. anything that has to do with the commercial relationship. The Subscription Profile on the other hand includes preferences that relate to the commercial agreement. GSSM scope relates to Service Subscription aspects, therefore the Enabler requirements only apply when the Subscription Profile is involved. In particular if a given Service Preference has no impact on the Subscription (i.e. is not part of the Subscription Profile), then managing this Service

Preference is out of GSSM scope. Of course there is no single view of which Service Preferences should be part of the Subscription Profile or not, because it all depends on the business choice of the service provider with regards to which Service Preferences have to go into the scope of the commercial relationship with the subscriber or not. For example, a Service Preference that will not be considered as a Subscription Profile for a service provider X (“I want to receive a news update on my phone every hour”), may actually be part of the Subscription Profile for a service provider Y --for example because the subscriber has explicitly subscribed (i.e. commercial relationship between the subscriber and the service provider) to news update being pushed every hour. An alternative example with codecs: Service Provider X may define their service offering such that any codec can be used to get access to the Channel content that has been subscribed. In that case the codec parameter is a pure Service Preference vs. Service Provider Y may segment their service offering such that subscriber Sub1 can subscribe to a service for a delivery with codec A, while subscriber Sub2 will get the service delivered using codec B. In that case the codec parameter is part of the Subscription Profile.

There is no pre-defined “static” boundary between the Service Preferences that are part of the Subscription Profile and the ones that are not, this frontier comes with the business choices made by the Service Provider. If a Service Preference is part of the Subscription Profile, then GSSM requirements will apply to this Service Preference; if not, then the management of this Service Preference is out of GSSM scope.

This approach is aligned with the TMF SID model [TMF GB922v6], which defines both a “Product” and “Service” business entity. The Subscription Profile relates to the SID “Product” business entity, while the “Service Preferences” relates to the “Service” one. The defined relationship “Product” – “Service” in the TMF model makes possible to have some Service Preferences being part of the Subscription Profile, while others are not. The section B.1 in Appendix provides further details on the service subscription data models compatibility.

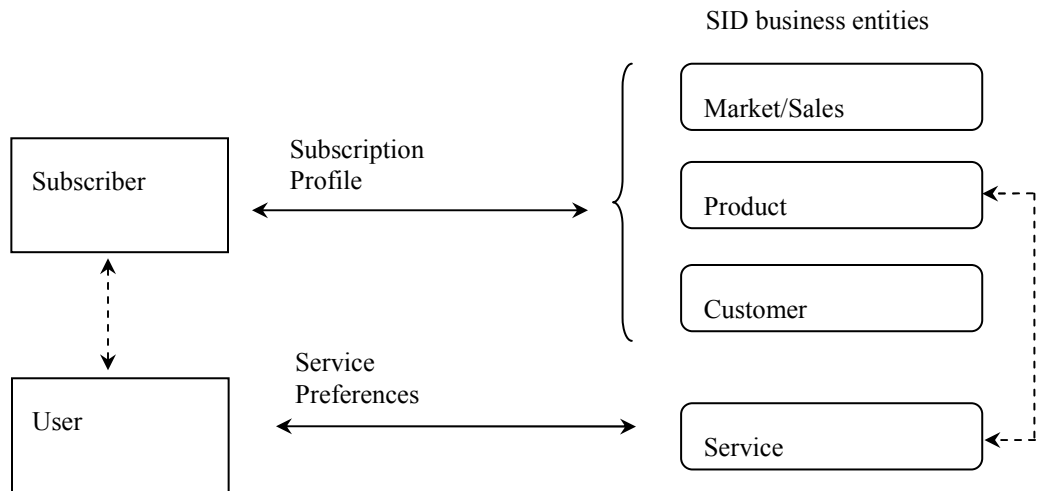

Figure 2: Relationship between Subscription Profile and Service Preferences

5. GSSM release description (Informative)

The GSSM enabler allows an authorized principal to setup, terminate, change, query subscriptions by actions such as subscribing and unsubscribing to services, registering authorized user(s) for using the service, and setting subscription preferences and/or service usage constraints for associated users(s). The main objective of this enabler is to specify a set of common functions for all of the service subscriptions within the service provider's domain and thus avoids the unnecessary complexity of a silo approach to subscription management.

5.1 Version 1.0

Version 1.0 of the GSSM Enabler RD includes requirements for the following functionality:

- Creation, Modification, Querying and Termination of Subscriptions to Services
- Management of Subscription Profiles
- Validation of Subscriptions
- Authentication and Authorization

6. Requirements

(Normative)

6.1 High-Level Functional Requirements

Label	Description	Enabler Release
HLF-1	The GSSM Enabler SHALL provide a mechanism for principals to manage service subscriptions.	GSSM 1.0
HLF-2	The GSSM Enabler SHALL provide a mechanism for principals to create, query, update, delete Subscription Profiles.	GSSM 1.0
HLF-3	The GSSM Enabler SHALL provide a mechanism for Subscription Validation.	GSSM 1.0
HLF-4	The GSSM Enabler SHALL be capable of ensuring that Service Subscription Provisioning is done (either doing so itself or by delegating to other Resources) upon request for service subscription management operation(s).	GSSM 1.0
HLF-5	The GSSM enabler MAY support registration and management of the service request for a network initiated service where the content can only be delivered if requested by an authorized principal.	GSSM 1.0
HLF-6	When the GSSM Enabler manipulates data shared with an external system (e.g. OSS/BSS), the data changes SHALL be consistent with data integrity rules and processes imposed by the external system.	Deleted
HLF-7	If the GSSM Enabler manipulates data owned by external systems (e.g. OSS/BSS), the data changes SHALL initiate the same flows in the external system as if the changes were performed by the external system itself.	Deleted

Table 1: High-Level Functional Requirements

6.1.1 Service Subscription Operations

Label	Description	Enabler Release
SSO-1	The GSSM Enabler SHALL provide the principal with a mechanism to subscribe principals(s) to a service.	GSSM 1.0
SSO-2	The GSSM Enabler SHALL provide the authorized principal with a mechanism to change the Subscription Profile (e.g., contents, channels, valid term).	GSSM 1.0
SSO-3	The GSSM Enabler SHALL provide the subscriber with the mechanism to suspend/resume the service subscription.	GSSM 1.0
SSO-4	The GSSM Enabler SHALL provide the authorised principal with a mechanism to unsubscribe from a service.	GSSM 1.0
SSO-5	The GSSM Enabler SHALL provide the authorised principal with a mechanism for querying the service subscriptions.	GSSM 1.0
SSO-6	The GSSM Enabler SHALL support the selective retrieval of Subscription Profiles based on the criteria in the Subscription Profile (e.g. subscription creation time, subscriber, user, service, subscription specific parameters).	GSSM 1.0
SSO-7	The GSSM Enabler SHALL be capable of delegating to related resources (such as business support systems, backend systems) using existing interfaces, part of the validation process for the new service subscription requests. Part of such validation processes to be taken by those business support systems, under a new service subscription request, could be: <ul style="list-style-type: none"> • Check if the user is not in a black list • Check if current pricing plans or product offerings for the user allows for subscribing to this service • Check compatibility of requested service with other services the user has already subscribed 	GSSM 1.0

Table 2: High-Level Functional Requirements – Service Subscription Operations

6.1.2 Subscription Validation Operations

Label	Description	Enabler Release
SV-1	The GSSM Enabler SHALL be capable of validating a subscription based on the following criteria: <ol style="list-style-type: none"> the service being requested, the principal for whom the service is being requested, the time when the service is being requested, the frequency with which the service is requested, e.g. how many times per day. preferred service delivery method(s), e.g. MMS, WAP. 	GSSM 1.0
SV-2	The GSSM Enabler SHALL be capable of delegating to related Resources using existing interfaces, part of the evaluation process for the validation of the Subscription.	GSSM 1.0
SV-3	The GSSM Enabler SHALL be capable of querying and retrieving from related Resources using existing interfaces, the necessary information to validate a subscription.	GSSM 1.0
SV-4	The GSSM Enabler SHALL be capable of providing in the Subscription Validation result the information necessary for the operation and execution of the service provided to the user.	GSSM 1.0
SV-5	Upon completion of the Subscription Validation, the GSSM Enabler SHALL be capable of delegating to related Resources part of the Service Subscription Provisioning process required for the delivery of the service to the user in accordance with the Subscription Profile.	GSSM 1.0
SV-6	The GSSM Enabler SHALL support selecting and requesting either subscription validation or retrieval of the Subscription Profile data, for example in order for the requestor to perform itself the validation operations.	GSSM 1.0
SV-7	The GSSM Enabler SHALL be capable of providing necessary group information (e.g. ID of group members) upon response to a validation request for a group subscription.	GSSM 1.0

Table 3: High-Level Functional Requirements – Subscription Validation Operations

6.1.3 Provisioning Related Operations

Label	Description	Enabler Release
PRO-1	The GSSM Enabler SHALL provide related resources with a notification mechanism for any subscription change (new subscription, modification, unsubscription).	Future Release
PRO-2	The GSSM Enabler SHALL provide the authorised principals with a notification mechanism for any subscription change.	Future Release
PRO-3	The GSSM Enabler SHALL provide the authorised principals with a confirmation mechanism for any subscription change.	Future Release
PRO-4	The GSSM Enabler SHALL be capable of notifying the authorised principal when the subscription is close to expiry.	Future Release

Table 4: High-Level Functional Requirements – Provisioning Related Operations

6.1.4 Security

Label	Description	Enabler Release
SEC-1	Mechanisms SHOULD be provided to protect data managed by the GSSM Enabler from corruption	GSSM 1.0
SEC-2	The GSSM Enabler SHOULD support mechanisms to log all subscription management operations	Future release
SEC-3	The GSSM Enabler SHALL protect against potential security threats, including denial-of-service attacks and exposure of data to unauthorized principals.	GSSM 1.0

Table 5: High-Level Functional Requirements – Security Items

6.1.4.1 Authentication

Label	Description	Enabler Release
GSSM-AUTHNT-1	The GSSM Enabler SHALL be compatible with mechanisms to authenticate principals who wish to perform subscription management functions	GSSM 1.0
GSSM-AUTHNT-2	The GSSM Enabler SHALL be compatible with mechanisms to authenticate principals wishing to perform a validation request to the GSSM enabler	GSSM 1.0
GSSM-AUTHNT-3	The GSSM Enabler MAY be capable of delegating the authentication to a related Resource.	GSSM 1.0

Table 6: High-Level Functional Requirements – Authentication Items

6.1.4.2 Authorization

Label	Description	Enabler Release
GSSM-AUTHOR-1	The GSSM Enabler SHALL be compatible with mechanisms to authorize principals wishing to subscribe to a service using the GSSM Enabler	GSSM 1.0
GSSM-AUTHOR-2	The GSSM Enabler SHALL be compatible with mechanisms to authorize principals wishing to un-subscribe from a service using the GSSM Enabler	GSSM 1.0
GSSM-AUTHOR-3	The GSSM Enabler SHALL be compatible with mechanisms to authorize principals wishing to perform data management functions (create, update, delete etc) to subscription profile(s)	GSSM 1.0
GSSM-AUTHOR-4	The GSSM Enabler SHALL be compatible with mechanisms to authorize principals wishing to perform a validation request to the GSSM Enabler	GSSM 1.0
GSSM-AUTHOR-5	The GSSM Enabler SHALL be capable of delegating the authorization to a related Resource.	GSSM 1.0

Table 7: High-Level Functional Requirements – Authorization Items

6.1.4.3 Data Integrity

Label	Description	Enabler Release
GSSM-INTEG-1	The GSSM Enabler SHALL support the data integrity of subscription management operations	GSSM 1.0
GSSM-INTEG-2	The GSSM Enabler SHALL support the data integrity of subscription validation requests and responses	GSSM 1.0

Table 8: High-Level Functional Requirements – Data Integrity Items

6.1.4.4 Confidentiality

Label	Description	Enabler Release
GSSM-CONFID-1	The GSSM Enabler SHOULD support the confidentiality of data exchanges between principals requesting subscription management and GSSM	GSSM 1.0

GSSM-CONFID-2	The GSSM Enabler SHALL support the confidentiality of all validation requests and responses to and from the GSSM Enabler	GSSM 1.0
GSSM-CONFID-3	The GSSM Enabler SHALL support the data confidentiality of Subscription Profiles	GSSM 1.0

Table 9: High-Level Functional Requirements – Confidentiality Items

6.1.5 Charging

There are no charging specific requirements. However, the charging entity could be included as a 'related Resource' as mentioned in other requirements.

6.1.6 Administration and Configuration

Label	Description	Enabler Release
AC-1	The GSSM Enabler SHALL provide the service provider with a mechanism to configure whether to perform the notification and/or confirmation for any subscription change.	Future Release
AC-2	The GSSM Enabler SHALL provide the service provider with a mechanism to configure which principals are required to confirm subscription changes.	Future Release
AC-3	The GSSM Enabler SHALL provide the service provider with a mechanism to configure the decision policy for resolving conflicting responses when multiple principals are required to confirm subscription changes.	Future Release
AC-4	The GSSM Enabler SHALL provide the service provider with mechanism to configure which Resources need to be notified of subscription changes.	Future Release

Table 10: High-Level Functional Requirements – Administration and Configuration Items

6.1.7 Privacy

Label	Description	Enabler Release
GSSM-PRV-1	The GSSM Enabler SHALL be compatible with mechanisms to protect the user identity from exposure to unauthorized principals.	GSSM 1.0

Table 11: High-Level Functional Requirements – Privacy Items

6.2 Overall System Requirements

Label	Description	Enabler Release
OSR-1	The GSSM Enabler SHALL NOT restrict deployment options.	GSSM 1.0
OSR-2	The GSSM Enabler SHALL be defined in an execution environment neutral manner.	GSSM 1.0
OSR-3	The GSSM Enabler SHALL specify interfaces that are access technology neutral.	GSSM 1.0
OSR-4	The GSSM Enabler SHALL be able to support services applicable to any kind of users or segments.	GSSM 1.0
OSR-5	The GSSM Enabler SHALL be able to use existing enablers where applicable.	GSSM 1.0

Table 12: High-Level System Requirements

Appendix A. Change History (Informative)

A.1 Approved Version History

Reference	Date	Description
n/a	n/a	No prior version –or- No previous version within OMA

A.2 Draft/Candidate Version 1.0 History

Document Identifier	Date	Sections	Description
Draft Versions OMA-RD-GSSM-V1_0	11 Aug 2006	5, 6	<ul style="list-style-type: none"> Added use case 5.1 and requirements HLF-1, HLF-2, HLF-3, HLF-4, HLF-5 and HLF-6 from OMA-GSSM-2006-0008-INP_service_subscription as agreed on CC 8th Aug.
	7 Sep 2006	5, 6	<ul style="list-style-type: none"> Amended requirement HLF-2 as proposed in OMA-GSSM-2006-0012R02-INP_A_Small_Change_from_Doc_8__2 and agreed at Beijing f2f 23rd Aug. Amended requirement HLF-3 as proposed in OMA-GSSM-2006-0013R02-INP_A_Small_Change_from_Doc_8__3 and agreed at Beijing f2f 23rd Aug. Added requirement HLF-7 as proposed in OMA-GSSM-2006-0014R02-INP_A_Small_Change_from_Doc_8__4 and agreed at Beijing f2f 23rd Aug. Added use case 5.2 and requirements HLF-8 and HLF-9 from OMA-GSSM-2006-0024R01-INP_Subscription_Validation_Use_Case as agreed at Beijing f2f 23rd Aug.
	10 Oct 2006	All	<ul style="list-style-type: none"> Implemented the following agreed CRs: <ul style="list-style-type: none"> OMA-GSSM-2006-0029R02-CR_Introduction_and_Scope OMA-GSSM-2006-0030R01-CR_Definitions_Abbreviations OMA-GSSM-2006-0031R02-CR_Improve_Consistency OMA-GSSM-2006-0022R03-CR_Service_Subscription_for_Groups OMA-GSSM-2006-0032R02-CR_Service_Validation_for_A_Group OMA-GSSM-2006-0038R02-CR_Charging_Use_Case OMA-GSSM-2006-0039-CR_Charging_Requirements
	24 Oct 2006	3.2, 5, 6	<ul style="list-style-type: none"> Resolve editorial error with duplication between HLF-8 and HLF-13 Implemented the following agreed CRs: <ul style="list-style-type: none"> OMA-GSSM-2006-0040R02-INP_Digital_Pets_Use_Case OMA-GSSM-2006-0048R02-CR_Definitions OMA-GSSM-2006-0056R02-CR_Charging_Use_Case_Subscription
	27 Nov 2006	3.2, 6.1	<ul style="list-style-type: none"> Implemented the following agreed CRs: <ul style="list-style-type: none"> OMA-GSSM-2006-0060-CR_Update_HLF_13 OMA-GSSM-2006-0067-INP_DCD_related_requirements
	4 Dec 2006	3.2, 5.8, 6.1	<ul style="list-style-type: none"> Implemented the following agreed CRs: <ul style="list-style-type: none"> OMA-GSSM-2006-0064R02-INP_service_content_based_subscription OMA-GSSM-2006-0068R02-CR_Subscription_validation_definition
	19 Dec 2006	4.2, 6.1	<ul style="list-style-type: none"> Implemented the following agreed CRs: <ul style="list-style-type: none"> OMA-GSSM-2006-0072R02-INP_analysis_refining_RD_requirements OMA-GSSM-2006-0076R01-CR_subscription_status_management OMA-GSSM-2006-0077R01-INP_Actor_Diagram
	17 Jan 2007	2.2, 4.3, 6.1.1	<ul style="list-style-type: none"> Implemented the following agreed CRs: <ul style="list-style-type: none"> OMA-GSSM-2006-0083R01-CR_Subscription_Validation_and_Credit_Control OMA-GSSM-2006-0084R03-CR_DCD_Enabler_requirements_analysis OMA-GSSM-2007-0001R01-CR_Security
	12 Feb 2007	2.1, 3.2, 4.1, 5.1, 5.9, 5.10, 6.1, 6.2	<ul style="list-style-type: none"> Implemented the following agreed CRs: <ul style="list-style-type: none"> OMA-GSSM-2007-0006R01-CR_ServiceSubscriptionProvisioning OMA-GSSM-2007-0013R01-CR_Management_of_Valid_Term OMA-GSSM-2007-0016R02-INP_Use_Case_Anonymous_User OMA-GSSM-2007-0017R01-CR_Charging_Requirements_Note OMA-GSSM-2007-0018R01-CR_Overall_System_Requirements OMA-GSSM-2007-0019R01-CR_Subscription_Validation_Definition OMA-GSSM-2007-0020R01-CR_Authentication_Intrinsic_Functions

Document Identifier	Date	Sections	Description
			<ul style="list-style-type: none"> ○ OMA-GSSM-2007-0021-CR_Remove_Empty_RD_Sections ○ OMA-GSSM-2007-0022R01-INP_revision_of_0012
	27 Feb 2007	2.2, 3.2, 5.7.5, 6.1	<ul style="list-style-type: none"> • Implemented the following agreed CRs: <ul style="list-style-type: none"> ○ OMA-REQ-GSSM-2007-0025-CR_Removal_of_HLF_14 ○ OMA-REQ-GSSM-2007-0026R01-CR_Reorganize_requirements_for_review ○ OMA-REQ-GSSM-2007-0028R02-CR_Charging_and_Service_Subscription_Provisioning
	30 Apr 2007	All	<ul style="list-style-type: none"> • Implemented the agreed changes in OMA-RDRR-GSSM-V1_0-20070419-D.
	28 May 2007	6.1.1, 6.1.3	<ul style="list-style-type: none"> • Implemented the agreed changes in OMA-RDRR-GSSM-V1_0-20070515-D. • Implemented the agreed contribution OMA-REQ-GSSM-2007-0044-INP_Subscription_Validation_Compromise.
	29 May 2007	6.1.1, 6.1.3, 6.1.4, 6.1.6	<ul style="list-style-type: none"> • Implemented the agreed changes in OMA-RDRR-GSSM-V1_0-20070529-D. • Implemented the agreed contributions OMA-REQ-GSSM-2007-0047-INP_Resolution_AI007.
	6 Jun 2007	4.1, 5.7.5, 6.1, 6.1.4, 6.1.6, 6.1.7, 6.2, Appdx B	<ul style="list-style-type: none"> • Implemented the agreed changes in OMA-RDRR-GSSM-V1_0-20070606-D. • Implemented the agreed contribution OMA-REQ-GSSM-2007-0049R01-INP_Proposal_Fix_BSS_issues.
	12 Jun 2007	3.2, 5.5.5, 5.5.7, 6.1, Appdx B.2	<ul style="list-style-type: none"> • Implemented the agreed changes in OMA-RDRR-GSSM-V1_0-20070612-D. • Implemented the agreed contribution OMA-REQ-GSSM-2007-0051R02-INP_User_Profile_and_Subscription_management_models_analysis. • Implemented editorial fixes agreed at Bangkok f2f: <ul style="list-style-type: none"> ○ Set enabler release to GSSM 1.0 for all requirements. ○ Fix typos in figure 15, figure 16 and requirement SEC-3. ○ Add definition for Service Provider and remove definition for Value Added Service Provider.
Candidate Versions OMA-RD-GSSM-V1_0	24 Jul 2007	All	Status changed to Candidate by TP: OMA Ref# OMA-TP-2007-0276R01-INP_GSSM_V1_0_RD_for_Candidate_Approval Updated with 2007 template and history box fixed.
Draft Version: OMA-RD-GSSM-V1_0	08 Jan 2009	All	Editorial fixes: 2009 template applied involving: Section 5 – Uses Cases moved to App B New Section 5 – GSSM release description Cross-references added Implemented agreed changes: OMA-ARC-GSSM-2008-0095-CR_RD_Removing_NotifConf_Configuration_from_GSSM1.0 OMA-ARC-GSSM-2008-0096-CR_RD_Removing_NotifConf_Mechanism_requirement_from_GSSM1.0
	21 Apr 2009	2.1 5	Implemented agreed change: OMA-ARC-GSSM-2009-0011-CR_GSSM_RD_Fixes
Candidate Version OMA-RD-GSSM-V1_0	26 May 2009	All	Status changed to Candidate by TP OMA-TP-2009-0201-INP_GSSM_V1_0_RD_for_Candidate_re_Approval
Draft Version: OMA-RD-GSSM-V1_0	17 Sep 2009	3.3, 4 5.1 6 6.1, 6.1.4	Implemented agreed changes as per comments from OMA-CONRR-GSSM-V1_0-20090907-D
	18 Sep 2009	3.3 6.1	Sections completed as per resolution of comments from OMA-CONRR-GSSM-V1_0-20090907-D
	07 Oct 2009	6	Requirements status fixed as per recommendations of the REQ WG following socialisation of changes.
Candidate Version OMA-RD-GSSM-V1_0	22 Oct 2009	All	Status changed to Candidate by TP: OMA-TP-2009-0488-INP_GSSM_V1_0_ERP_for_Candidate_Approval

Appendix B. Use Cases (Informative)

B.1 Service Subscription for Digital Newspaper Service

B.1.1 Short Description

A “digital newspaper service”, provided to mobile network users in Beijing, delivers news information including text, pictures, and short video clips to subscribers of the service via MMS. James is an office staff working in Beijing, and he would like to view some news for killing time when he is on the way to his office by subway. He finds the digital newspaper service complies with his requirement, and likes to subscribe to the service.

B.1.2 Actors

- James, a mobile user of local mobile operator (acts as the *User* and *Subscriber* of the service).
- BeijingMobileInfo.com, a Content provider which owns the digital newspaper service applications (act as the *Content Provider* of the service) .
- Mobile operator offering GSSM and a service portal (acts as *Service Provider*).

B.1.2.1 Actor Specific Issues

- James
 - Wants to subscribe to the digital newspaper service.
 - Agrees to pay for using the service.
- BeijingMobileInfo.com
 - Wants to offer the digital newspaper to subscribers of the service.
 - Wants to use mobile operator’s network resources to deliver the content of the service.
 - Wants to obtain revenue for providing the content.
- Mobile operator,
 - Wants to establish agreements with third parties content providers to offer the digital newspaper service to mobile network users.
 - Wants to present the service and offer easy service subscription.
 - Wants unwilling users (who do not subscribe to the service) not to be bothered by this service.
 - Wants to reduce the complexity of service subscription provisioning
 - Wants to avoid revenue management issues for both users and content providers.

B.1.2.2 Actor Specific Benefits

- James
 - Easily be subscribed to the digital newspaper service and receive the message containing digital newspaper content.
- BeijingMobileInfo.com
 - Easily delivers the service to subscribers (users who subscribed to the service).
 - Get the precise information about the number of subscribers without dealing with the service subscription process itself.
- Mobile operator

- Establishes agreements with third parties content providers to increase its revenues and enrich services portfolio.
- Offers users a generic easy way of subscribing service provided by third parties.
- Easily provisions subscriber’s subscription information into his infrastructure.

B.1.3 Pre-conditions

- BeijingMobileInfo.com has developed a “digital newspaper service” application and has prepared the mechanism of organizing contents and delivering them to market.
- BeijingMobileInfo.com has an agreement with the mobile operator so that the mobile users could use “digital newspaper service” local mobile operator’s network.
- The “digital newspaper service” has been registered in mobile operator’s system and presented on operator’s service portal to mobile network users.
- GSSM obtains necessary service data about digital newspaper service.

B.1.4 Post-conditions

- James is subscribed to the service for every morning’s delivery of a digital newspaper to his mobile terminal.
- James can enjoy the service according to his subscription terms and preferences.

B.1.5 Normal Flow

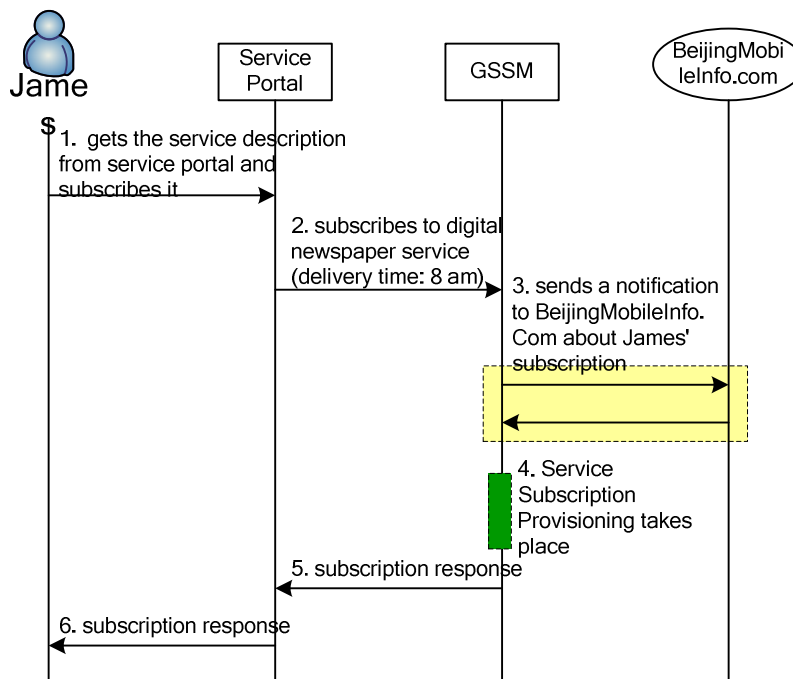

Figure 3: Service Subscription for "Digital Newspaper Service" (Normal Flow)

1. James gets service description about the “digital newspaper service” from the service portal presenting the information, and finds that it complies with his requirement. James initiates a service subscription on the service portal.
2. The service portal sends the service subscription request to GSSM, with the delivery time of the digital newspaper set to 8am every morning.
3. GSSM sends a notification about the James’ subscription to BeijingMobileInfo.com.

4. Service Subscription Provisioning takes place. GSSM makes sure that proper actions take place in the operator’s infrastructure in order to fulfil end user service subscription
5. GSSM sends the subscription response to the service portal.
6. Service portal forwards the subscription response to James.

Steps 5 and 6 may take place before or after step 4, depending on the type of message that the operator wants to send to the user (i.e.: “your service subscription will be ready in a few minutes”, or “your subscription is ready. You can start enjoying your service”, etc.)

B.1.6 Alternative Flow 1: Subscription with Subscriber’s Confirmation

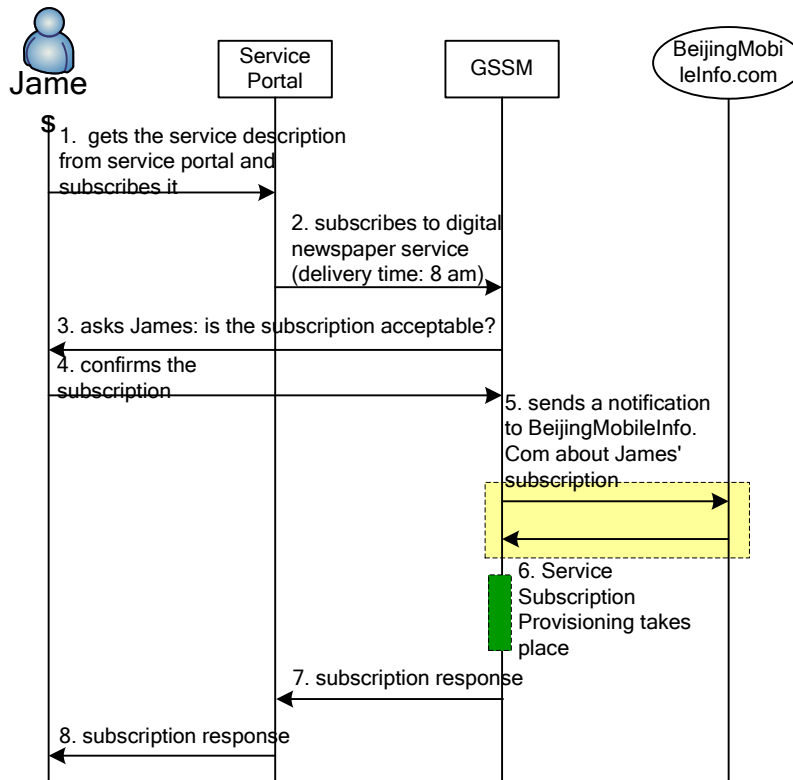

Figure 4: Service Subscription for "Digital Newspaper Service" (Alternative Flow 1)

- 1-2. (Same as step 1-2 of Normal Flow).
3. GSSM asks James to confirm the subscription (e.g., by sending him a message with some service information which may include the service name, price, delivery time, etc.).
4. James confirms the subscription.
5. GSSM sends a notification about the James’ subscription to BeijingMobileInfo.com.
6. Service Subscription Provisioning takes place. GSSM makes sure that proper actions take place in the operator’s infrastructure in order to fulfil end user service subscription request .
- 7-8. (Same as step 5-6 of Normal Flow).

Steps 7 and 8 may take place before of after step 6, depending on the type of message that the operator wants to send to the user (i.e.: “your service subscription will be ready in a few minutes”, or “your subscription is ready. You can start enjoying your service”, etc.)

B.1.7 Alternative Flow 2: Subscription with Notification to the Subscriber

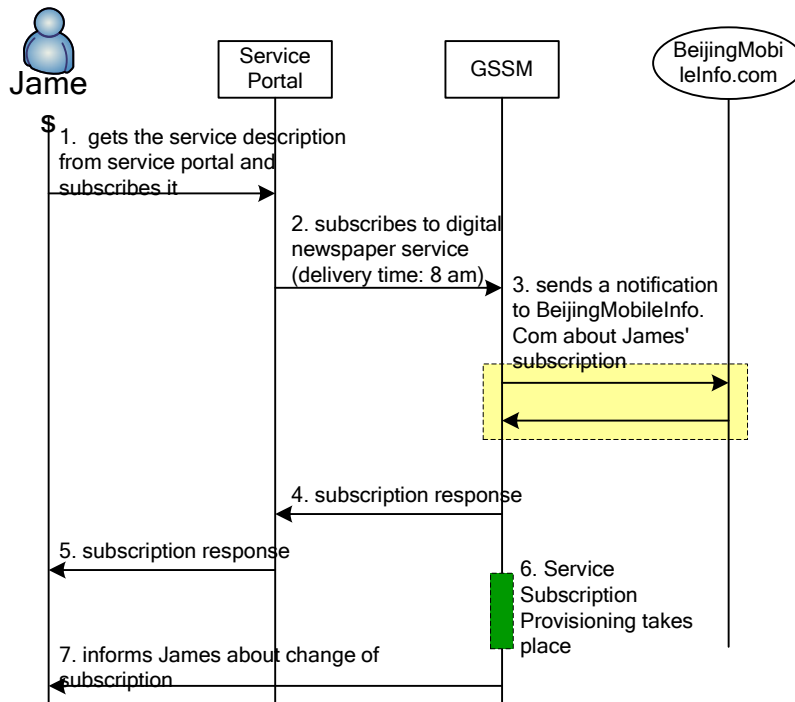

Figure 5: Service Subscription for "Digital Newspaper Service" (Alternative Flow 2)

1-3. (Same as step 1-3 of Normal Flow).

4-5. (Same as step 5-6 of Normal Flow).

6. Provisioning of Subscription changes takes place. GSSM makes sure that proper actions take place in the operator's infrastructure in order to fulfil end user service subscription change request.

7. GSSM informs James that he is subscribed to the service (e.g., by sending him a message with some service information which may include the service name, price, delivery time, etc.).

Note that step 5 & 6 could happen in alternative order.

B.1.8 Alternative Flow 3: Subscription from CP

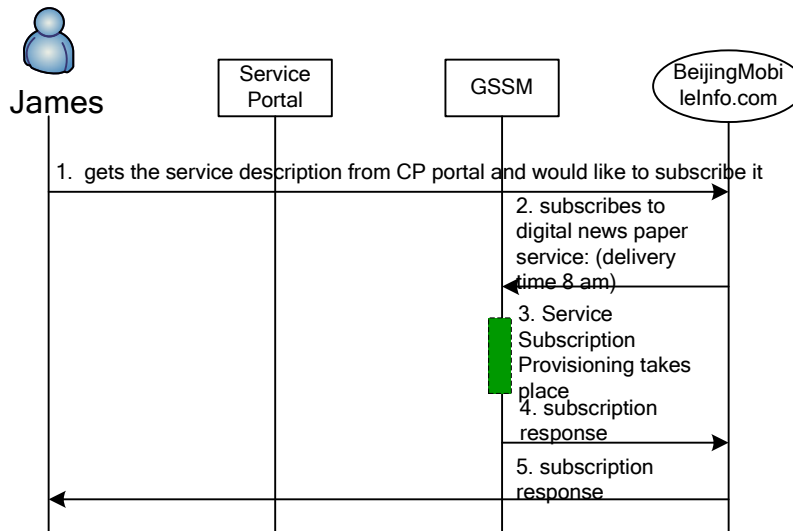

Figure 6: Service Subscription for "Digital Newspaper Service" (Alternative Flow 3)

1. James gets service description about the “digital newspaper service” from BeijingMobileInfo.com, finds it interesting, and he is willing to try the service.
2. James subscribes the digital newspaper service on GSSM via the portal or the application on BeijingMobileInfo.com, and sets that the digital newspaper be delivered to his terminal at about 8 am every morning.
3. Service Subscription Provisioning takes place. GSSM makes sure that proper actions take place in the operator’s infrastructure in order to fulfil end user service subscription request
4. GSSM sends the subscription response to the BeijingMobileInfo.com.
5. BeijingMobileInfo.com forwards the subscription response to James.

B.1.9 Alternative Flow 4: Unsubscribe

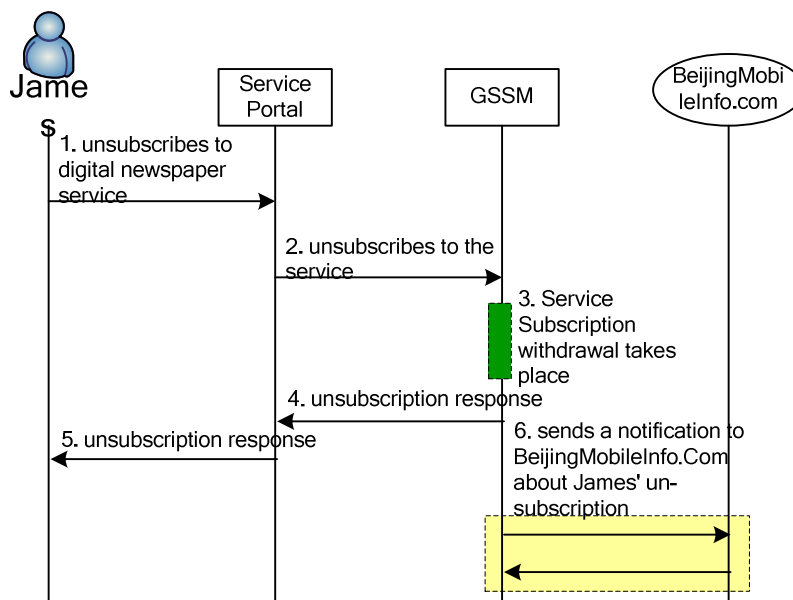

Figure 7: Unsubscribe to "Digital Newspaper Service" (Alternative Flow 4)

James unsubscribes to the service on GSSM via the service portal, and GSSM notifies James’s unsubscribe to BeijingMobileInfo.com. Then GSSM informs James the cancellation of current service subscription. Note that steps 3, 4, 5 and 6 could slightly vary their order.

B.1.10 Alternative Flow 5: Validation Against Business Support Systems and Final Notification

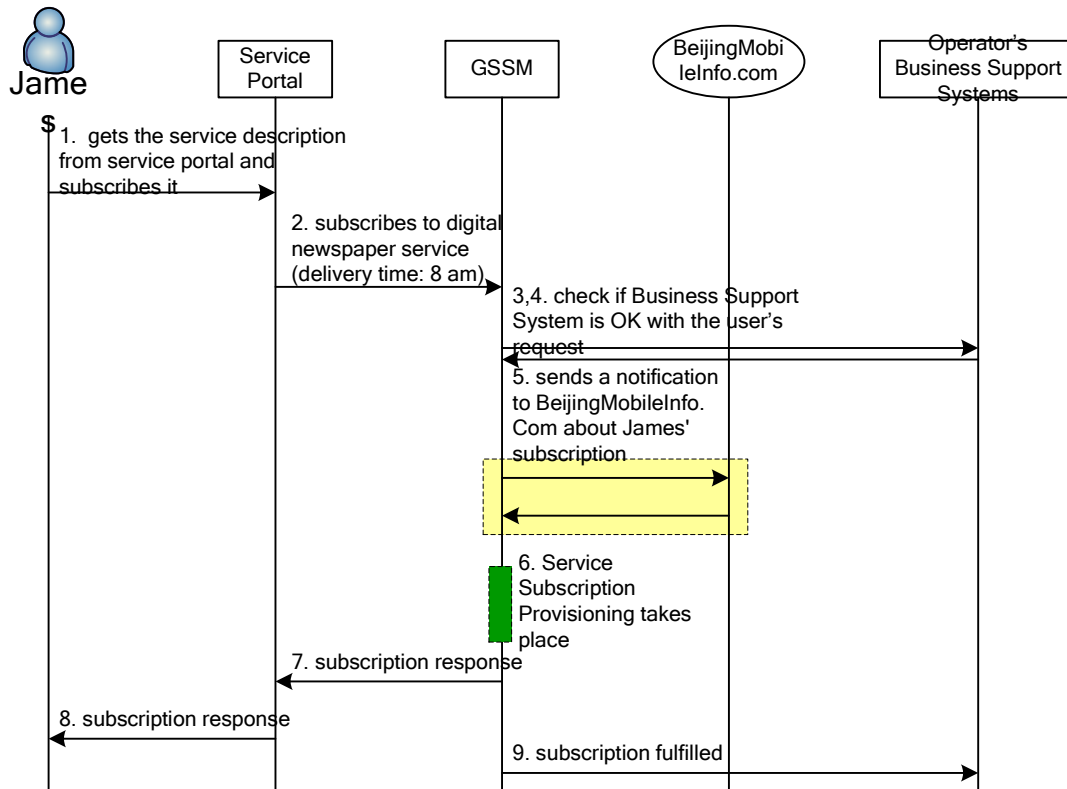

Figure 8: Validation Against BSS and Final Notification for "Digital Newspaper Service" (Alternative Flow 5)

1. James gets service description about the “digital newspaper service” from the service portal presenting the information, and finds that it complies with his requirement. Therefore James is interested in trying the service.
2. James subscribes the digital newspaper service on GSSM via the service portal, and sets that the digital newspaper be delivered to his terminal at about 8 am every morning.
3. and 4: Check against operators business support subsystems if subscription request is OK, so that a series of validations can be made, e.g.: check if user’s on a black list, check if end user’s pricing plans allows for this subscriptions, check if requested services is incompatible with other services the user is enjoying, etc.
5. GSSM sends a notification about the James’ subscription to BeijingMobileInfo.com.
6. Service Subscription Provisioning takes place. GSSM makes sure that proper actions take place in the operator’s infrastructure in order to fulfil end user service subscription.
7. GSSM sends the subscription response to the service portal.
8. Service Portal forwards the subscription response to James.
9. GSSM notifies business support systems that service subscription has been created.

B.1.11 Operational and Quality of Experience Requirements

None

B.2 Service Subscription Validation for Indie Music Bundle

B.2.1 Short Description

A Mobile Operator has recognized that independent record companies do not possess the subscription and charging infrastructure to offer music downloads to their fans at a competitive rate. To satisfy this need, the Mobile Operator has created an Indie Music Bundle service which allows fans of non-mainstream music to download content from 50 independent record companies for a single monthly fee based on a maximum number of track downloads per month.

Todd is a big fan of progressive thrash metal music and is frustrated by the lack of this genre on the major music download sites. He wants better value for his download dollar than the price per track rate and more variety than that provided by a single record company. He decides the Indie Music Bundle meets his needs and subscribes to the service level offering 10 tracks per month for \$4.99.

B.2.2 Actors

- Todd, a mobile user and customer of the Mobile Operator (acts as the *User* and *Subscriber*).
- Blue Dog Records: A content provider which owns the rights to the music tracks (acts as *Content Provider*).
- Mobile Operators offering a subscriber self-care service portal and GSSM (acts as *Service Provider*).

B.2.2.1 Actor Specific Issues

- Todd:
 - Wants to download music tracks from multiple independent records companies.
 - Agrees to pay the monthly fee for using the service.
- Blue Dog Records:
 - Wants to offer music downloads to subscribers of the Mobile Operator.
 - Wants to use the mobile operator's network resources to deliver the content of the service.
 - Wants to obtain revenue corresponding to the number of tracks downloaded by the mobile operator's subscribers.
- Mobile operator:
 - Wants to establish agreements with independent records companies seeking to offer their tracks for download by mobile network users.
 - Wants to present the service and offer easy service subscription.
 - Wants to police the service and prevent usage beyond that allowed by the subscription.
 - Wants to avoid revenue management issues for both users and content providers.

B.2.2.2 Actor Specific Benefits

- Todd:
 - Greater music choice with reduced cost per track.
- Blue Dog Records:
 - Revenue assurance for downloaded music.
 - Larger audiences for content without subscription and charging infrastructure costs.
- Mobile operator:
 - Increased revenues and enriched services portfolio.

B.2.3 Pre-conditions

- Blue Dog Records has signed an agreement with the Mobile Operator to allow its mobile users to download music tracks except during the hours of 9am to 5pm, Monday to Friday.
- Todd has visited the Mobile Operator's self care service portal and subscribed to the Indie Music Bundle for 10 track downloads per month.

B.2.4 Post-conditions

- Todd has successfully downloaded a music track from Blue Dog Records to his mobile terminal.

B.2.5 Normal Flow

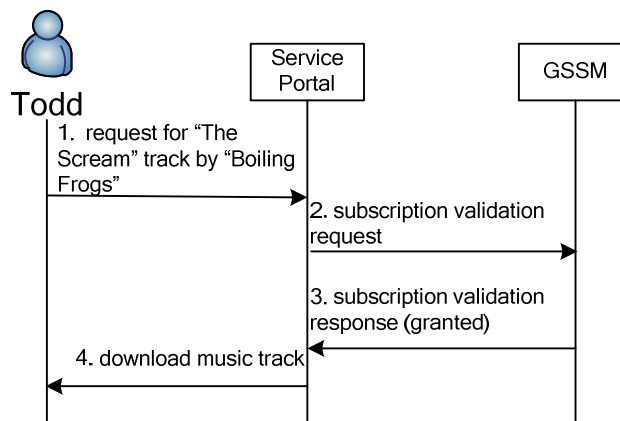

Figure 9: Subscription Validation for "Indie Music Bundle" (Normal Flow)

1. Todd launches the browser on his mobile terminal and access the Blue Dog Records portal where he identifies himself as an Indie Music Bundle subscriber. Todd finds that Blue Dog Records have just released a new track called "The Scream" from his favourite band "Boiling Frogs" and requests the download.
2. The Blue Dog Records portal submits a subscription validation request to the GSSM requesting permission to allow Todd to download content.
3. The GSSM validates that the service request is within the limits defined by the subscription profile for both Blue Dogs Records (content provider) and Todd (subscriber). The GSSM returns a Subscription Check Response granting Blue Dog Records to download content to Todd's mobile terminal.
4. Blue Dog Records downloads the track to Todd's mobile terminal.

B.2.6 Alternative Flow 1: Subscriber Service Level Violation

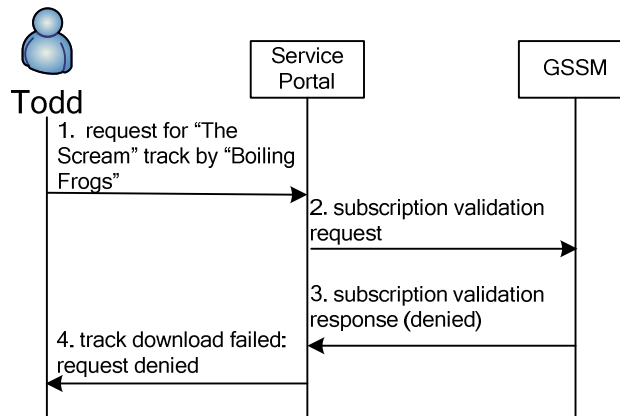

Figure 10: Subscription Validation for "Indie Music Bundle" (Alternative Flow 1)

1-2. (Same as step 1-2 of Normal Flow).

3. The GSSM validates that the service request is within the limits defined by the subscription profile for both Blue Dogs Records (content provider) and Todd (subscriber). However, Todd has already downloaded 10 tracks in the past month so this download violates the Indie Bundle 10 track download limit for Todd (subscriber). The GSSM returns a Subscription Check Response denying Blue Dog Records the right to download content to Todd's mobile terminal.

4. Blue Dog Records informs Todd that his download request has been denied.

B.2.7 Alternative Flow 2: Content Provider Service Level Violation

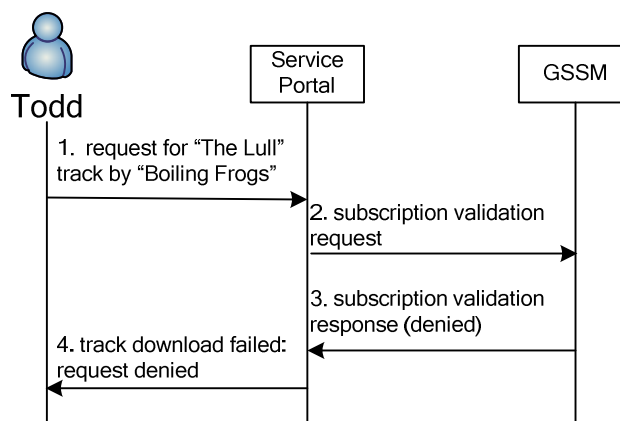

Figure 11: Subscription Validation for "Indie Music Bundle" (Alternative Flow 2)

1. At 8:59am on Monday, Todd launches the browser on his mobile terminal and access the Blue Dog Records portal where he identifies himself as an Indie Music Bundle subscriber. Todd finds that Blue Dog Records have just released another track called "The Lull" by "Boiling Frogs". However, Todd wasn't impressed with their previous track and hesitates before deciding to download this latest track.

2. At 9:01am on Monday, the Blue Dog Records portal submits a subscription check request to the GSSM requesting permission to allow Todd to download content.

3. The GSSM validates that the service request is within the limits defined by the subscription profile for Todd (subscriber). However, the download is not within the time window allowed under the agreement with Blue Dogs

Records (content provider). The GSSM returns a Subscription Check Response denying Blue Dog Records the right to download content to Todd's mobile terminal.

4. Blue Dog Records informs Todd that his download request has been denied.

B.2.8 Operational and Quality of Experience Requirements

None

B.3 Service Subscription for Groups

B.3.1 Short Description

A “digital newspaper service”, provided to mobile network users in Beijing, delivers news information including text, pictures, and short video clips to subscribers of the service via MMS. Alice and Bob are the office staff working for the same corporation in Beijing. John is the manager of the corporation and he would like to provide his staff the possibility to view some news for killing time when they are on the way to their office by subway. John registered a Group to include Alice and Bob. He subscribed the digital newspaper service for his group and every morning a multimedia message containing up-to-time news is sent to the devices of each individual user in John's group, namely to Alice and Bob. When they are on the subway they can open the messages and view the news.

B.3.2 Actors

- John, a principal who initiates the subscription of the service (acts as *Subscriber*).
- Alice and Bob, the group users of the service (acts as *Users*).
- BeijingMobileInfo.com, a content provider which owns the digital newspaper service applications. (acts as *Content Provider*)
- Mobile operator acts as Service Provider.

B.3.2.1 Actor Specific Issues

- John
 - Agrees to pay for using the service.
- Alice and Bob
 - Want to use the services (e.g. digital newspaper service) subscribed for the group.
- BeijingMobileInfo.com
 - Wants to offer the digital newspaper service to subscribers of the service.
 - Wants to use mobile operator's network resources to deliver the content of the service.
- Mobile operator,
 - Wants to establish agreements with third parties content providers to offer mobile services (e.g. the digital newspaper service) to mobile network users.
 - Wants to present the service and offer easy service subscription to individual users and group users.

B.3.2.2 Actor Specific Benefits

- John
 - Easily subscribes for multiple users to mobile services (e.g. the digital newspaper) by using service subscription for groups.
 - Easily changes the subscription to include more group users, or subscribes new services.
- Mobile operator

- Provide an easy way to maintain the subscription for multiple users by providing service subscription for groups.
- Alice and Bob
 - Share all the services subscribed for the group (e.g. receive the message containing digital newspaper content).

B.3.3 Pre-conditions

- John has previously registered Group1 including Alice and Bob in Mobile operator domain.
- Alice and Bob’s devices all have the ability of receiving and sending information via MMS.

B.3.4 Post-conditions

- Group1 is subscribed to the service for every morning’s delivery of a digital newspaper to the group users.

B.3.5 Normal Flow

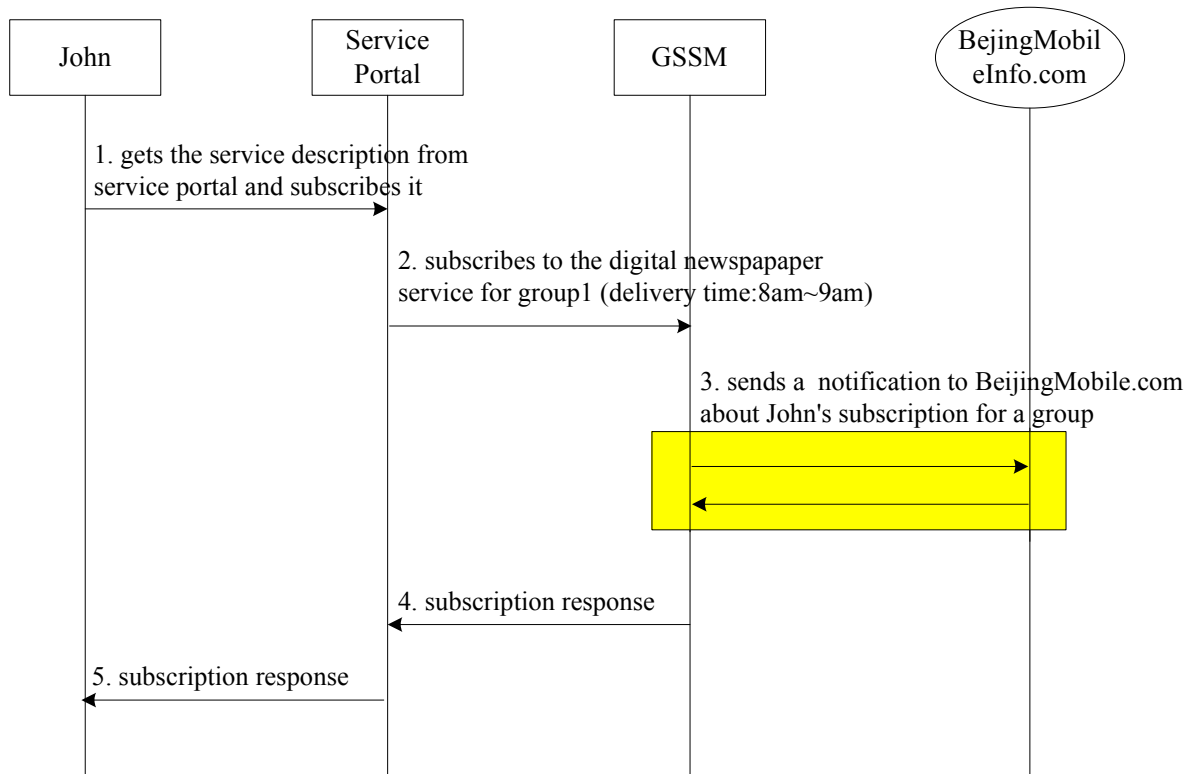

Figure 12: Service Subscription for a Group (Normal Flow)

1. John gets the information about the digital newspaper service from the service portal of mobile operator or network operator. And he would like to provide the service to his staff, Alice and Bob (namely John’s group users).
2. John subscribes the digital newspaper service for Group1 and sets the digital newspaper should be delivered to the user group from 8am to 9am every morning.
3. Information about Johns’ subscription to the service for Group1 is notified to the service application in BeijingMobileInfo.com.
4. A response may be returned to the service portal indicating the subscription is successful.
5. John is notified the successful subscription response from the service portal. Alice and Bob may also be notified according to the subscription preference.

B.3.6 Operational and Quality of Experience Requirements

None

B.4 Service Validation for a Group

B.4.1 Short Description

A “digital newspaper service”, provided to mobile network users in Beijing, delivers news information including text, pictures, and short video clips to subscribers of the service via MMS. Alice and Bob are the office staffs working for the same corporation in Beijing. John is the manager of the corporation and he would like to provide his staff the possibility to view some news for killing time when they are on the way to their office by subway. John registered a Group to include Alice and Bob. He subscribed the digital newspaper service for his group and every morning a multimedia message containing up-to-time news is sent to the devices of users in John’s group, namely to Alice and Bob. When they are on the subway they can open the messages and view the news.

B.4.2 Actors

- Alice and Bob, group users of the service (acts as *Users*).
- BeijingMobileInfo.com, a content provider which owns the digital newspaper service applications (acts as *Content Provider*).
- Mobile operator (acts as *Service Provider*).

B.4.2.1 Actor Specific Issues

- Alice and Bob
 - Want to use the services (e.g. digital newspaper service) subscribed for the group.
- BeijingMobileInfo.com
 - Wants to offer the digital newspaper service to subscribers of the service.
 - Wants to use mobile operator’s network resources to deliver the content of the service.
- Mobile operator,
 - Wants unwilling users (who do not subscribed to the service) not to be bothered by this service.
 - Wants to avoid billing fault for both mobile network users and content providers.

B.4.2.2 Actor Specific Benefits

- Mobile operator
 - Protects the information of the group users.
 - Reduces the interacting times with the Content Provider;
 - The network burden between the Mobile operator and the Content Provider is lightened.
- Alice and Bob
 - Share all the services subscribed for the group (e.g. receive the message containing digital newspaper content).

B.4.3 Pre-conditions

- Alice and Bob are members of Group1.
- Alice’s and Bob’s devices have the ability of receiving information via MMS.
- Group1 is subscribed to the digital newspaper service.

B.4.4 Post-conditions

- MMS messages containing the digital newspaper content are sent to Alice and Bob every morning according to group subscription information and subscription preference.

B.4.5 Normal Flow

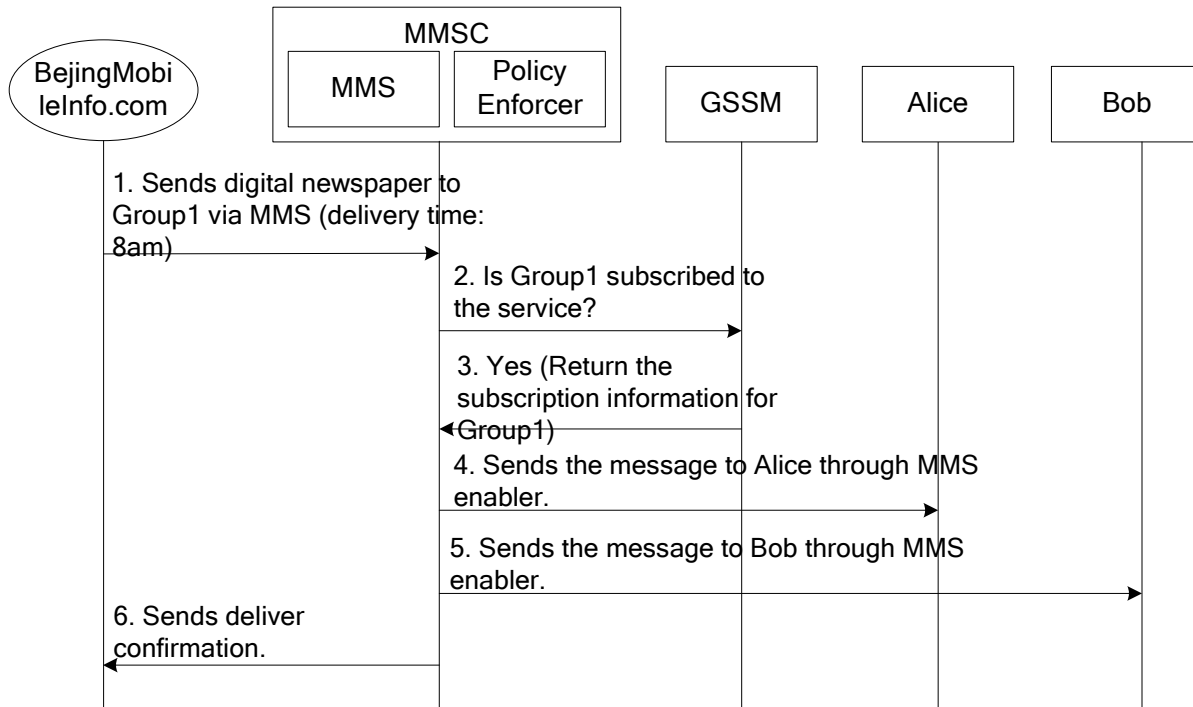

Figure 13: Service Validation for a Group (Normal Flow)

- At 8: am every morning digital newspaper service application sends a multimedia message to group1 containing the digital newspaper content via MMS enabler of the mobile operator.
- Policy Enforcer sends a request to GSSM for verifying the validation of the subscription.
- After subscription validation, GSSM responds to Policy Enforcer indicating that the subscription is valid. At the same time, the group subscription information (e.g. MSISDN of Alice and Bob) is returned.
- Digital newspaper service delivers the multimedia message from BeijingMobileInfo.com to Alice through MMS enabler.
- Digital newspaper service delivers the multimedia message from BeijingMobileInfo.com to Bob through MMS enabler.
- A response may be returned from Policy Enforcer to BeijingMobileInfo.com.

B.4.6 Alternative Flow: Subscription Preference Violation

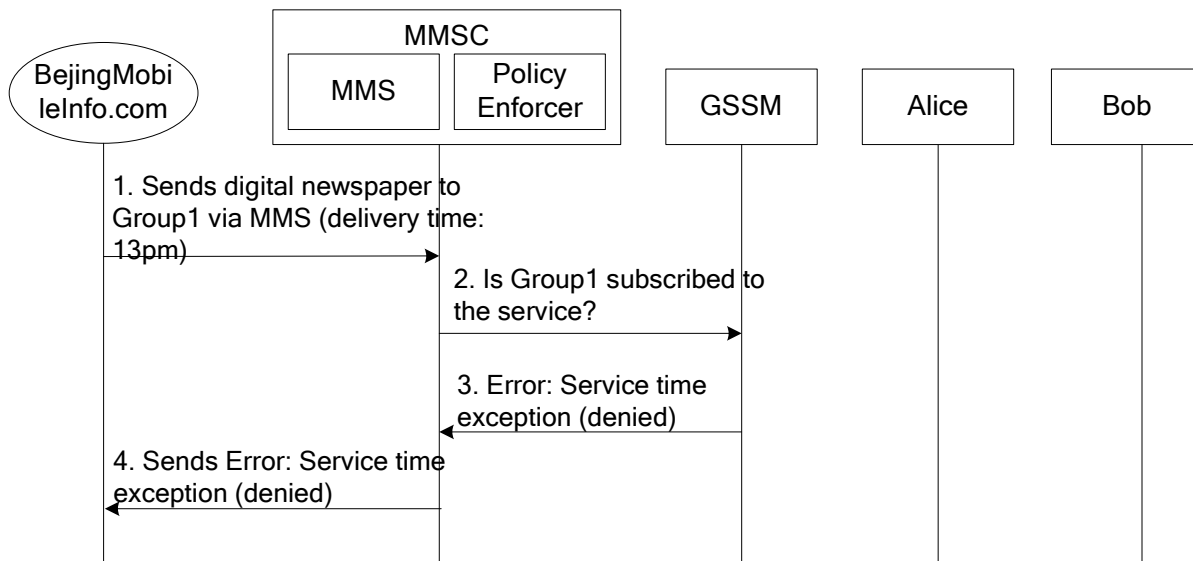

Figure 14: Service Validation for a Group (Alternative Flow)

1. A digital newspaper is delivered via MMS to Group1 containing the digital newspaper content at 13: pm in one afternoon.
2. Policy Enforcer sends a request to GSSM to validate the subscription for Group1.
3. GSSM finds that the service time is not conform to the subscription preference of Group1, therefore GSSM responds to Policy Enforcer indicating the ‘error service time’ exception condition.
4. Policy Enforcer returns the information to BeijingMobileInfo.com, and the message will not be delivered to the users within Group1.

B.4.7 Operational and Quality of Experience Requirements

None

B.5 Multi-Enabler-based service: Digital Pets

B.5.1 Short Description

Keeping a pet in digital environment is very popular among the young people. A Mobile Operator, BeijingMobileInfo.com, has created a “Digital Pets” service to satisfy the requirement. The user can feed or play with the “pet” via the service application. The user is reminded of the status of the pet via MMS every morning.

Sunny wants to have a dog, but he doesn’t have enough time to take care of it so Sunny chooses to use the “Digital Pets” service instead.

B.5.2 Actors

- Sunny, a mobile user of local mobile operator (acts as the *User* and *Subscriber*).
- BeijingMobileInfo.com, a Content Provider which owns the “Digital Pets” service applications (act as the *Content Provider*).
- Mobile operator offering GSSM, WAP Portal and MMS enablers (acts as *Service Provider*).

B.5.2.1 Actor Specific Issues

- Sunny

- Wants to use the “Digital Pets” service.
- Agrees to pay for using the service.
- BeijingMobileInfo.com
 - Wants to offer the “Digital Pets” service to subscribers of the service.
 - Wants to use mobile operator’s network resources to deliver the content for the service.
- Mobile operator
 - Wants to make sure the “Digital Pets” service is offered to mobile network users who subscribed to the service.

B.5.2.2 Actor Specific Benefits

- Sunny
 - Easily receives the information from his “pet”, and has interactive operations with his pet through WAP mode.
- BeijingMobileInfo.com
 - Easily delivers the service to subscribers (users who subscribed to the service).
- Mobile operator
 - Offers a mobile network user the service that is subscribed by him/her.

B.5.3 Pre-conditions

- BeijingMobileInfo.com has developed a “Digital Pets” service application, and the service has been registered in mobile operator’s system.
- The mobile operator’s WAP Portal provides an entrance of the “Digital Pets” service for users.
- BeijingMobileInfo.com is aware of the use of GSSM when sending MMS to subscribers.
- GSSM obtains necessary configuration information about “Digital Pets” service. (eg. the enablers involved in the service)
- Sunny has subscribed to the “Digital Pets” service.

B.5.4 Post-conditions

- Sunny has a digital pet via “Digital Pets” service.

B.5.5 Normal Flow

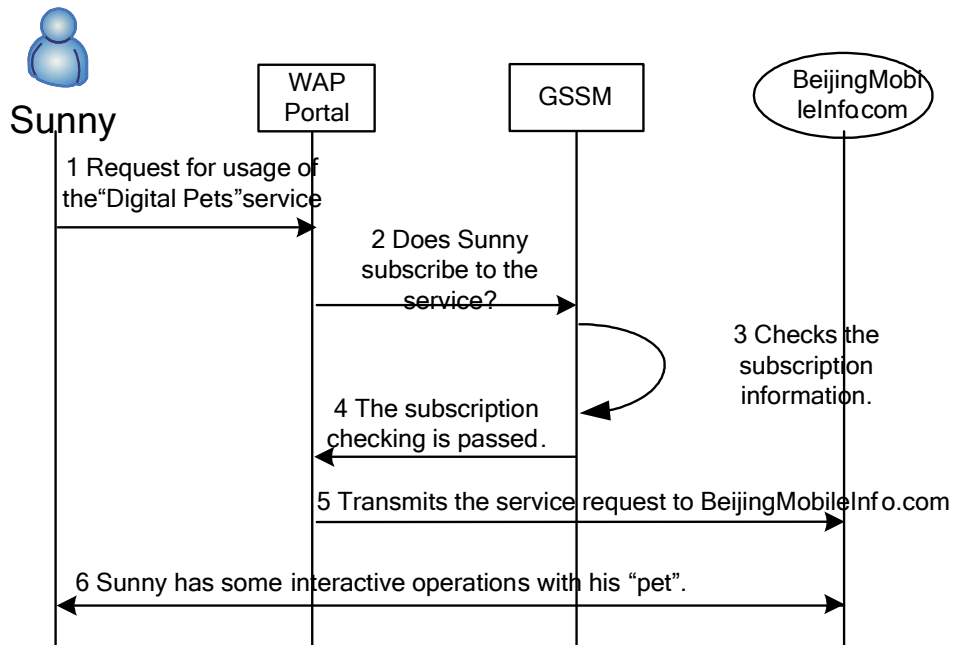

Figure 15: Subscription Validation for “Digital Pets” Service (Normal Flow 1)

1. Sunny browses the WAP Portal of the mobile operator, and requests for the usage of “Digital Pets” service.
2. The WAP Portal sends a request to GSSM for validate the subscription.
3. GSSM checks the subscription information to make sure Sunny has subscribed “Digital Pets” service.
4. GSSM responds WAP Portal indicating that the subscription is valid.
5. WAP Portal transmits Sunny’ request to BeijingMobileInfo.com.
6. Sunny has some interactive operations with his “pet” through the service application.

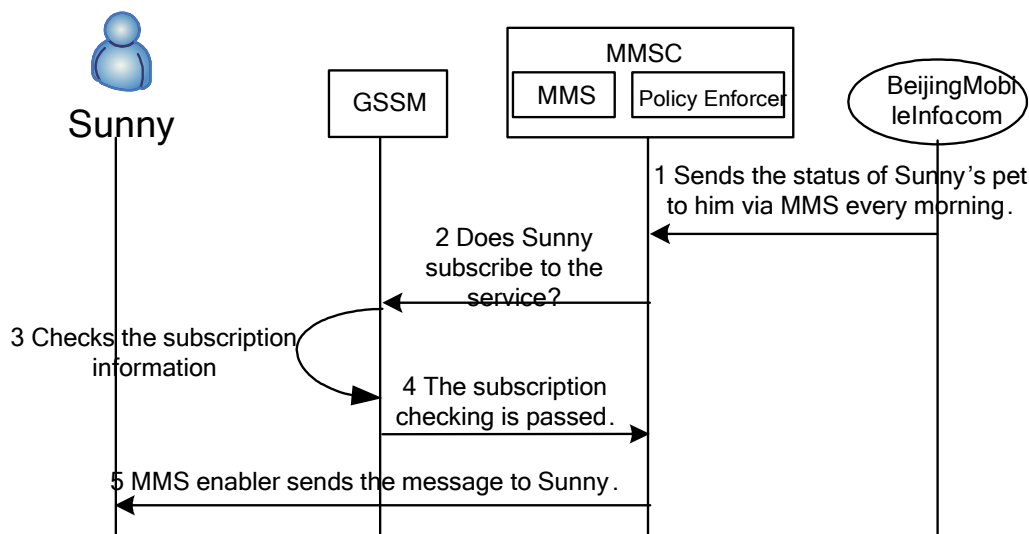

Figure 16: Subscription Validation for “Digital Pets” Service (Normal Flow 2)

1. The status of Sunny’s pet is delivered via MMS to him every morning.

2. Policy Enforcer in MMSC (MMS Centre) sends a request to GSSM for validating the subscription.
3. GSSM checks the subscription information to make sure Sunny has subscribed “Digital Pets” service.
4. GSSM responds Policy Enforcer indicating that the subscription is valid.
5. The MMS message is delivered to Sunny.

B.5.6 Alternative Flow 1: Subscription Absence

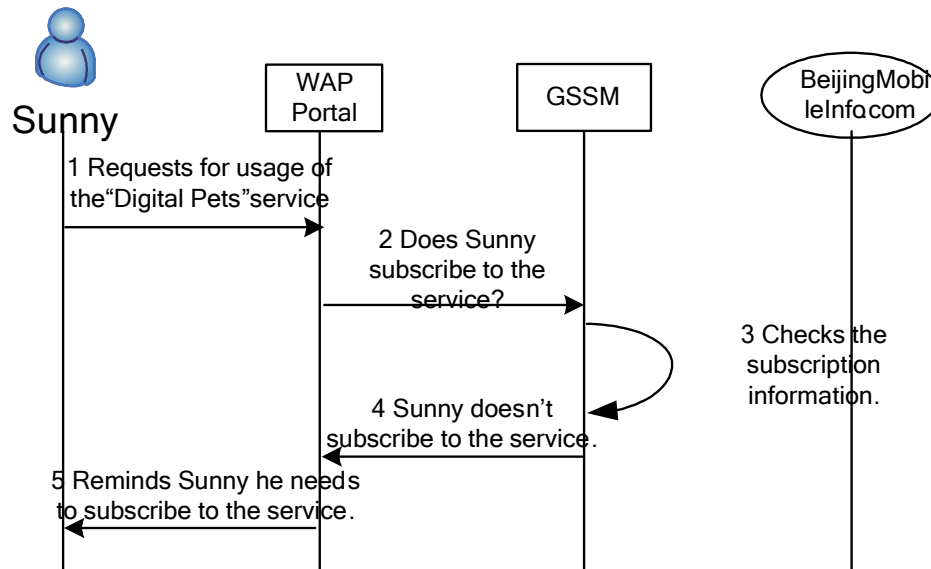

Figure 17: Subscription Validation for “Digital Pets” Service (Alternative Flow 1)

Note: In the flow, Sunny doesn’t subscribe to the service, or he has unsubscribed to the service. If he tries to use the service, the WAP Portal gets a negative result about the subscription validation from GSSM and will deny the requests.

1. Sunny browses the WAP Portal of the mobile operator, and requests for the usage of “Digital Pets” service.
2. The WAP Portal sends a request to GSSM for validate the subscription.
3. GSSM finds that Sunny doesn’t subscribe to the service yet.
4. GSSM responds WAP Portal indicating the error.
5. WAP Portal reminds Sunny to subscribe the service.

B.5.7 Alternative Flow 2: Criteria of Subscription Invalid

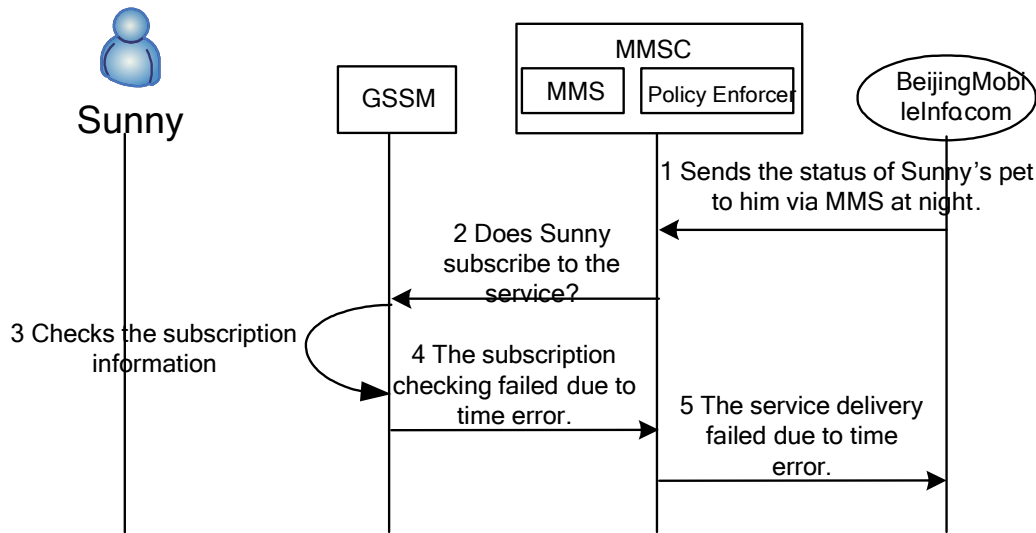

Figure 18: Subscription Validation for “Digital Pets” Service (Alternative Flow 2)

1. The status of Sunny’s pet is delivered to him via MMS at night.
2. Policy Enforcer in MMSC sends a request to GSSM for validating the subscription.
3. GSSM finds that the delivery time is beyond the time window of the service.
4. GSSM responds to the Policy Enforcer indicating the time error.
5. MMSC returns the information to BeijingMobileInfo.com, and the message will not be delivered to Sunny.

B.6 Charging For Service Subscription

B.6.1 Short Description

This charging use case elaborates further what requirements exist when it comes to charging for service subscription.

B.6.2 Actors

- Todd, a mobile user and customer of the Mobile Operator (acts as the *User* and *Subscriber*).
- Blue Dog Records: A content provider which owns the rights to the music tracks (acts as *Content Provider*).
- Mobile Operators offering a subscriber self-care service portal and GSSM (acts as *Service Provider*).

B.6.3 Pre-conditions

- Blue Dog Records has signed an agreement with the Mobile Operator to allow its mobile users to download music tracks.
- Todd has visited the Mobile Operator’s self care service portal and subscribes to the Blue Dog Records for 10 track downloads per month.

B.6.4 Post-conditions

- Todd has successfully subscribed to the new service.

B.6.5 Normal Flow

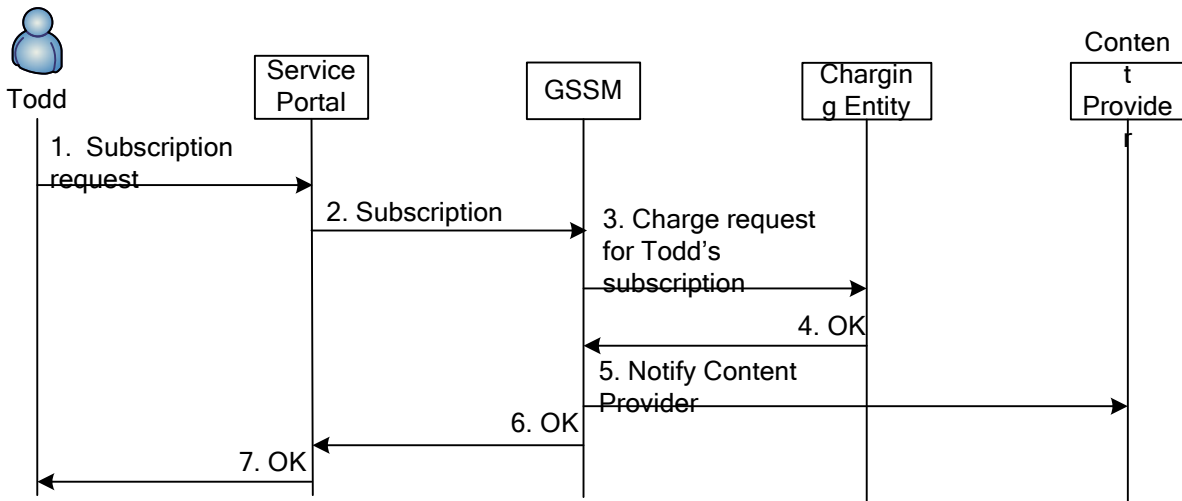

Figure 19: Charging for Service Subscription (Normal Flow)

1. Todd gets service description about the “Track Download” from the service portal presenting the information and decides to try the service.
2. Todd subscribes the “Track Download” service on GSSM via the service portal.
3. GSSM submits a Charging Event Request to the Charging Entity in regards to Todd’s subscription.
4. The Charging Entity returns a Charging Response including the result of the Charging Event Request.
5. GSSM notifies the Blue Dog Records.
6. GSSM sends the subscription response to the service portal.
7. Service portal forwards the subscription response to Todd.

B.6.6 Alternative Flow: No Service Portal

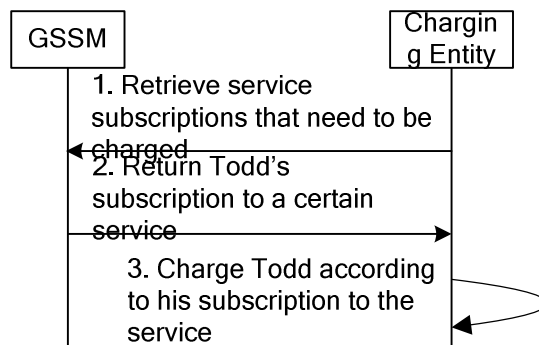

Figure 20: Charging For Service Subscription (Alternative Flow)

1. Charging entity retrieves service subscriptions that need to be charged from GSSM.
2. GSSM return the list of service subscriptions to be charged (the returned service subscriptions satisfy the charging condition set by the service provider), where Todd’s subscription is included.
3. Charging entity charges Todd according to his subscription information given by GSSM.

B.7 Charging On Subscription Validation

B.7.1 Short Description

This charging use case elaborates further what requirements exist when it comes to charging on subscription validation.

B.7.2 Actors

- Todd, a mobile user and customer of the Mobile Operator (acts as *User* and *Subscriber*).
- Blue Dog Records: A content provider which owns the rights to the music tracks (acts as *Content Provider*).
- Mobile Operator offering a subscriber self-care service portal and GSSM (acts as *Service Provider*).

B.7.3 Pre-conditions

- Blue Dog Records has signed an agreement with the Mobile Operator to allow its mobile users to download music tracks.
- Todd has visited the Mobile Operator’s self care service portal and subscribed to the Blue Dog Records for 10 track downloads per month.

B.7.4 Post-conditions

- Todd has successfully downloaded the first music track from Blue Dog Records to his mobile terminal. Todd has 9 more tracks left for download in the current month.

B.7.5 Normal Flow

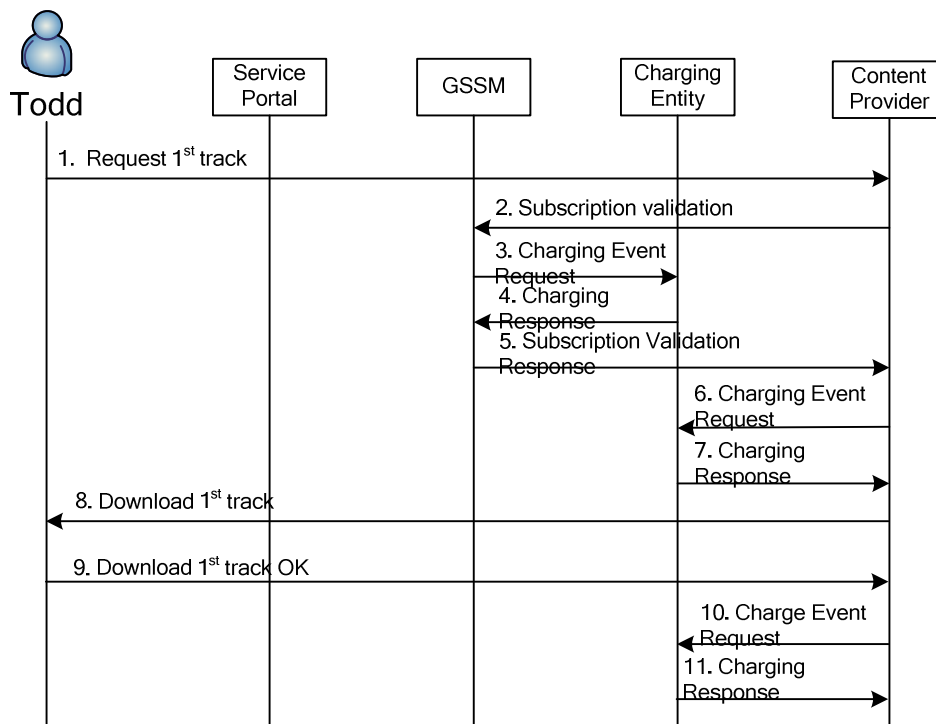

Figure 21: Subscription Validation for "Blue Dog Records" (Normal Flow)

1. Todd launches the browser on his mobile terminal and accesses the Blue Dog Records portal where he identifies himself as Blue Dog Records subscriber. Todd finds that Blue Dog Records have just released a new track called "The Scream" from his favourite band "Boiling Frogs" and requests the download.

2. The Blue Dog Records portal submits a subscription validation request to the GSSM requesting permission to allow Todd to download content.
3. The GSSM may check with the Charging Entity if Todd has credit for the subscription.
4. The Charging Entity returns a confirmation that Todd still has credit for the subscription.
5. The GSSM returns a Subscription Validation Response granting Blue Dog Records to download content to Todd's mobile terminal. The GSSM enabler sends to the requestor the information on how this event should be charged, e.g. Charging Entity address, online, offline charging or no charging.
6. Blue Dog Records sends a Charging Event Request for credit reservation to the Charging Entity.
7. The Charging Entity confirms the credit reservation.
8. Blue Dog Records downloads the track to Todd's mobile terminal.
9. After the confirmation from the Todd's terminal has been received that the download has been successful,
10. Blue Dog Records requests the Charging Entity to debit the units used.
11. The Charging Entity confirms the debit units.

B.8 Content-based service: The Choice is up 2U

B.8.1 Short Description

A mobile operator has created the "The Choice is up 2U" service to provide online streaming service to users. The service includes several TV channels: MTV, Movie, Sports, News, etc. The service subscription enables users to select 3 favourite channels out of 12 offered channels. The favourite channels can be viewed at all times. Other channels are barred. The user can reselect the 3 channels anytime against a small cost.

Sunny is MTV fan. He'd like to watch MTV and other channels for fun. Sunny subscribes to the service.

B.8.2 Actors

- Sunny, a mobile user of local mobile operator (acts as the *User* and *Subscriber*).
- Mobile operator offering GSSM, Service Portal, and the service component (acts as *Service Provider*).

B.8.2.1 Actor Specific Issues

- Sunny
 - Wants to use the "The Choice is up 2U" service.
 - is interested in MTV Channel in the service.
 - Agrees to pay for using the service.
- Mobile operator
 - Wants to offer the "The Choice is up 2U" service to subscribers.

B.8.2.2 Actor Specific Benefits

- Sunny
 - Can enjoy MTV and other favourite channels at his mobile terminal anywhere and anytime.
- Mobile operator
 - Sells attractive service and increases revenue.

B.8.3 Pre-conditions

1. The mobile operator has developed the “The Choice is up 2U” service application, and the service has been deployed in the streaming enabler.
2. The mobile operator’s Service Portal provides the description of the “The Choice is up 2U” service as well as the entrance to the service application.
3. GSSM obtains necessary configuration information (information of channels) about “The Choice is up 2U” service.

B.8.4 Post-conditions

Sunny enjoys the MTV and other channels provided by the “The Choice is up 2U” service. The operator increases the revenue.

B.8.5 Normal Flow

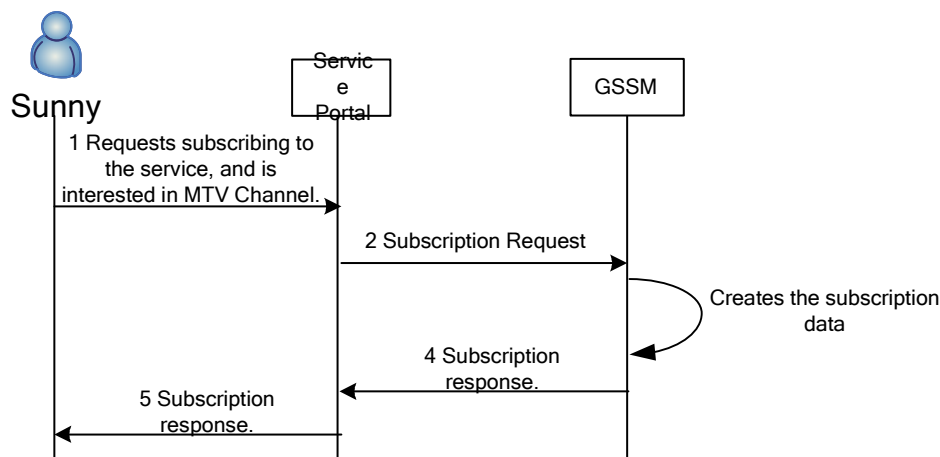

Figure 22: Subscription for Content of a Service (Normal Flow 1)

1. Sunny gets service description about the “The Choice is up 2U” from the service portal, and decides to subscribe to it. At the time of subscription Sunny selects MTV, and two other channels.
2. Sunny’s subscription request is sent to GSSM via the service portal.
3. GSSM creates the subscription profile for Sunny’s subscription to the service and channel.
4. GSSM sends the subscription response to the service portal.
5. Service portal forwards the subscription response to Sunny.

Note: the service portal can be any entities that present service information to subscribers for subscription, e.g., portal systems or enablers/applications.

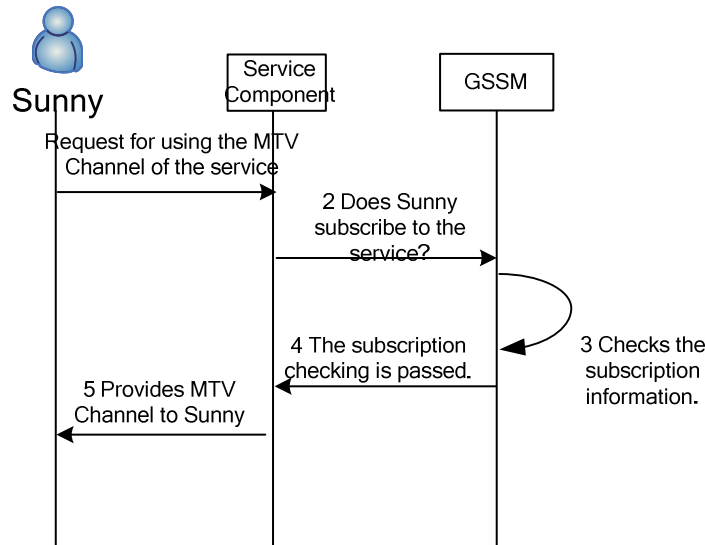

Figure 23: Using the Subscribed Content of the Service (Normal Flow 2)

1. At a later point in time, Sunny wants to watch the MTV Channel, and initiates the service on his terminal, where service requests is delivered to the service component.
2. The service component sends a request to GSSM for validating the subscription.
3. GSSM checks the subscription information to make sure Sunny has subscribed to the service requested. GSSM checks the channel selected and finds that MTV is in the list of favourite channels.
4. GSSM responds the service request indicating that the subscription is valid.
5. The service component provides the MTV channel to Sunny, and Sunny enjoys the MTV Channel.

Note: the service component can be any enablers or applications that provide services for users.

B.8.6 Alternative Flow 1: Service Component Initiated Push Service

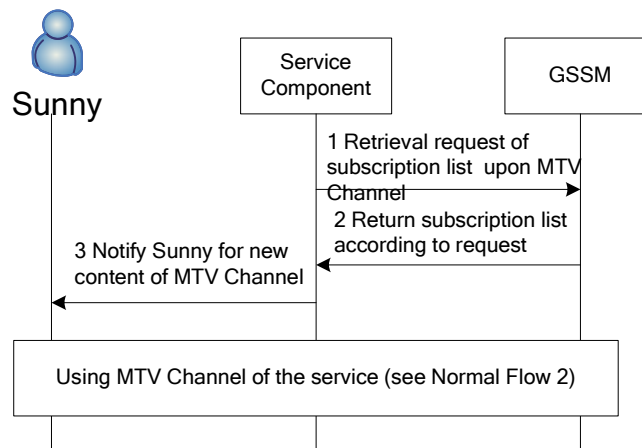

Figure 24: Using the Subscribed Content of the Service (Alternative Flow 1)

1. When obtaining some new contents for MTV Channel, the Service Component sends a request to GSSM, retrieving the list of subscriptions that subscribed to the MTV Channel of the service.
2. GSSM returns the subscription list of MTV Channel of the service according to request, which include Sunny’s subscription.

3. Service Component sends notifications to Sunny, informing him (or his service client) the newly available content of MTV Channel.

Following steps describe Sunny's downloading new contents from MTV Channels, same as the flows depicted in **Error! Reference source not found.** The steps can be either triggered by Sunny when seeing the notification message, or by the service client automatically when a notification is received.

B.8.7 Alternative Flow 2: Subscription Validation Fails

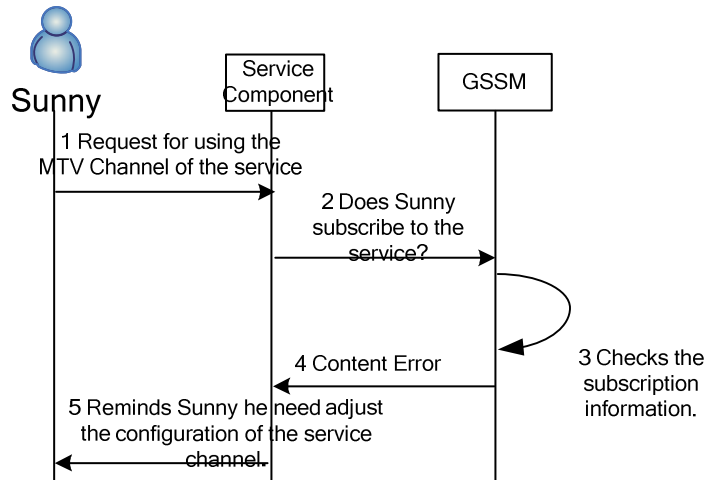

Figure 25: Subscription Validation for a Service (Alternative Flow)

1. Sunny wants to watch the MTV Channel, and initiates the service on his terminal, where service requests is delivered to the service component
2. The Service Portal sends a request to GSSM to validate the subscription.
3. GSSM checks the subscription information to find out that MTV Channel is not in the list of content in the subscription.
4. GSSM returns the information that the service validation failed with result code.
5. Service Portal reminds Sunny that he could reselect the favourite channels against a small cost.

B.9 Subscription Management for On-Request Service: Stock Quotation Live

B.9.1 Short Description

“Stock Quotation Live” is an on-request service, i.e., a network initiated service where the content can only be delivered if requested by an authorized principal. It delivers information of stock quotation to users only when users ask for the information. “Stock Quotation Live” service requires users send service request via short message, and returns users the corresponding stock quotation via multimedia message.

James is an office staff working in Beijing. James invests parts of his savings in stocks, so he wants to obtain the information of stock quotation at any moment. The “Stock Quotation Live” service complies with his requirement.

B.9.2 Actors

- James, a mobile user of local mobile operator (acts as *User* and *Subscriber*).
- BeijingMobileInfo.com, a content provider that owns the “Stock Quotation Live” service applications (acts as the *Content Provider*).

- Mobile operator offering application platform, GSSM, SMS and MMS enablers (acts as *Service Provider*).

B.9.2.1 Actor Specific Issues

- James
 - Wants to use the “Stock Quotation Live” service.
 - Wants to get stock information only when he sends service request.
- BeijingMobileInfo.com
 - Wants to offer the “Stock Quotation Live” service to subscribers of the service.
 - Wants to use mobile operator’s network resources to deliver the content of the service.
- Mobile operator
 - Wants to make sure the “Stock Quotation Live” service is offered to mobile network users who subscribed to the service.

B.9.2.2 Actor Specific Benefits

- James
 - Easily receives the information of stock quotation on his request at any moment.
- BeijingMobileInfo.com
 - Easily delivers the service to subscribers (users who subscribed to the service) on his request.
- Mobile operator
 - Offers a mobile network user the service that is subscribed by him/her.

B.9.3 Pre-conditions

- BeijingMobileInfo.com has developed a “Stock Quotation Live” service and has prepared the mechanism of organizing contents and delivering them to market.
- Mobile operator is ready to provide the service to users by setting up the application platform that can be used by on-request type of service.
- James has subscribed to the “Stock Quotation Live” service.
- GSSM obtains necessary configuration information about “Stock Quotation Live”. (e.g. the calling sequence of enablers of service provision.)

B.9.4 Post-conditions

- James successfully receives the required stock information by multimedia message sent from the content provider.

B.9.5 Normal Flow

1. James requests for information of stock quotation by sending a short message to the application platform of mobile operator.
2. The application platform recognizes James’ request and sends an “on-request service request registration” message to GSSM.
3. GSSM validates the James’ subscription to the stock service, records information about service request registration, and send an acknowledgement indicating a successful registration to the application platform.
4. The application platform forwards the service request to BeijingMobileInfo.com.
5. BeijingMobileInfo.com sends corresponding stock quotation information to MMSC.
6. Policy Enforcer in MMSC (MMS Centre) sends a request to GSSM for validating the subscription.

7. GSSM checks subscription information and the stored registration information to make sure James has subscribed the service and the request of this MMS has been registered.
8. GSSM responds Policy Enforcer indicating that sending multimedia message to James is permitted.
9. The multimedia message is delivered to James.

B.9.6 Alternative Flow 1: Subscription Invalid

Note: In this flow, James doesn't subscribe to the service, or he has unsubscribed to the service.

1. James requests for information of stock quotation by sending a short message to the application platform of mobile operator.
2. The application platform recognizes James' request and sends an "on-request service request registration" message to GSSM.
3. GSSM finds that the subscription is invalid.
4. GSSM responds the application platform indicating the error.
5. The application platform denies the service request sent by James.

B.9.7 Alternative Flow 2: BeijingMobileInfo.com Sends an Unsolicited Message

Note: In this flow, BeijingMobileInfo.com tries to deliver contents of service to James without request.

1. The content of "Stock Quotation Live" for James is delivered to MMSC via multimedia message.
2. Policy Enforcer in MMSC sends a request to GSSM for validating the subscription.
3. GSSM checks subscription information and the recorded registration information, but does not find any registration information that indicates James has requested the stock quotation information.
4. GSSM responds Policy Enforce in MMSC indicating an validation error.
5. MMSC denies the multimedia message forward request of BeijingMobileInfo.com, and the multimedia message will not be delivered to James.

B.10 Service Subscription for Anonymous Users

B.10.1 Short Description

A "digital sport newspaper service", provided to mobile network users in Madrid, delivers sport news to subscribers of the service via MMS. Pepe would like use this service but Pepe wants to preserve his privacy, he doesn't want that this provider knows his MSISDN. He subscribes the digital newspaper service with the Anonymous User conditions.

The Anonymous User conditions say: The Content Provider doesn't know the user's MSISDN. The Content Provider will use other user's identity (e.g. PseudoId).

B.10.2 Actors

- Pepe, mobile user (acts as *User* and *Subscriber*).
- SportNews.com, a content provider which owns the digital sport newspaper service applications (*acts as Content Provider*).
- Mobile operator offering GSSM and MMS enablers (acts as *Service Provider*).

B.10.2.1 Actor Specific Issues

- Pepe
 - Agrees to pay the bill of using the service.

- Doesn't want that SportNews.com knows his MSISDN.
- SportNews.com
 - Wants to offer the digital sport newspaper service to of the service.
 - Wants to use mobile operator's network resources to deliver the content of the service.
 - Wants to obtain corresponding revenue according to the number of subscribers or users to the service.
- Mobile operator,
 - Wants to establish agreements with third parties content providers to offer mobile services to mobile network users.
 - Wants to present the service and offer easy service subscription to user and preserve their privacy.
 - Manages the user's identity.

B.10.2.2 Actor Specific Benefits

- Pepe
 - Easily subscribes to the digital sport newspaper service.
 - To be an anonymous user for SportNews.com.
- SportNews.com
 - Provide an easy way to maintain the subscription for a user by providing service subscription for anonymous users.
- Mobile operator
 - Protects the information security of the user.

B.10.3 Pre-conditions

- The operator manager, at least two different user's identities:
 1. MSISDN
 2. Anonymous identity. In this use case it will be a PseudoId.
- SportNews.com only knows the PseudoId as User's Identity.
- In the service's Profile Subscription is defining that the content provider can not know the user's MSISDN.
- Pepe's devices all have the ability of receiving and sending information via MMS according the Subscription Profile.

B.10.4 Post-conditions

- MMS containing the digital sport newspaper content is sending to Pepe according to Pepe's subscription to the service.

B.10.5 Normal Flow: Subscription for an Anonymous User

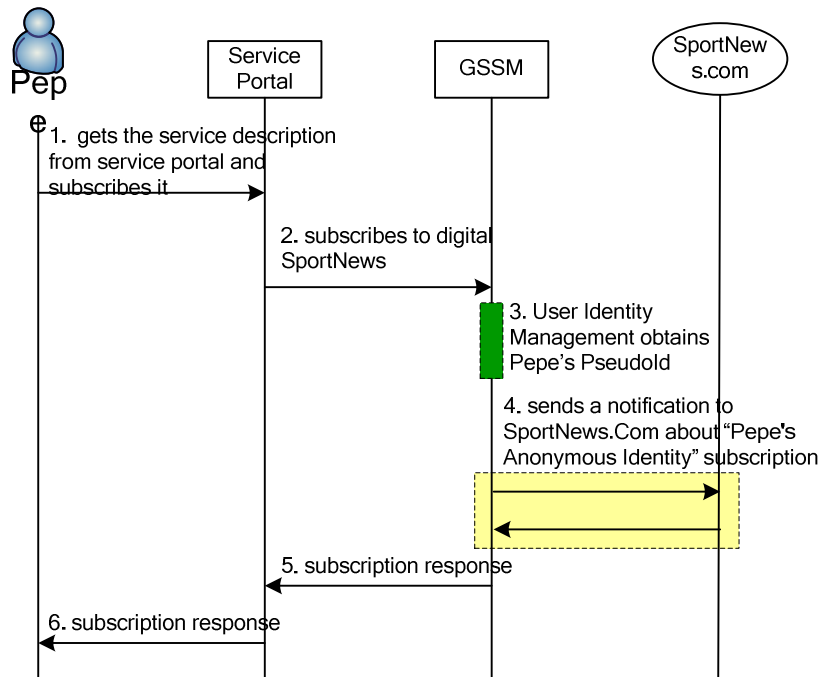

Figure 26: Service Subscription for an Anonymous User (Normal Flow)

1. Pepe gets the information about the digital Sport newspaper service from the service portal of mobile operator or network operator. And he would like to subscribe to the service.
2. Pepe subscribes the digital newspaper service to GSSM.
3. The GSSM (itself or delegating to other resources) manages the Pepe’s identity and obtains Pepe’s Pseudoid.
4. GSSM sends a notification about Pepe’s Subscription to SportNew.com. In this notification, sends the “Pseudoid” as User’s identity.
5. A response may be returned to the service portal indicating the subscription is successful.
6. Pepe is notified the successful subscription response from the service portal.

B.10.6 Normal Flow: Validation for an Anonymous User

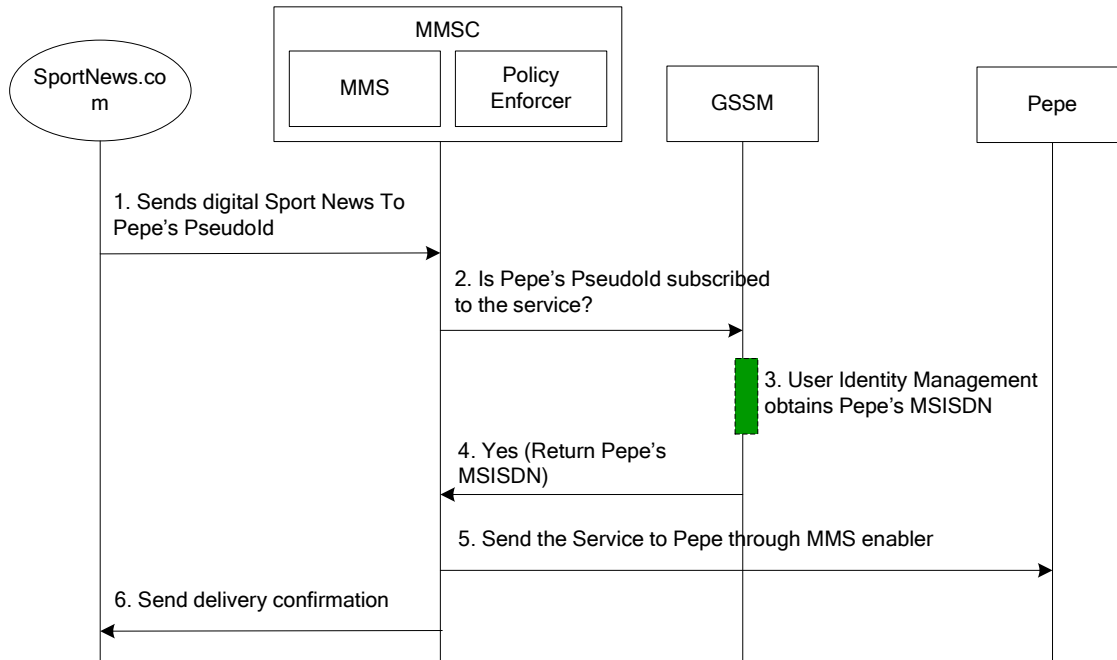

Figure 27: Service Validation for an Anonymous User (Normal Flow)

1. The digital Sport Newspaper service application sends a MMS with the Sport content to Pepe. SportNews.com only knows the Pseudoid as Pepe's Identity.
2. Policy Enforcer sends a request to GSSM for verifying the validation of the subscription. The Policy Enforcer uses for this validation the Pseudoid as User's identity.
3. The GSSM (itself or delegating to other resources) manages the Pepe's identity and obtains the Pepe's MSISDN.
4. After checking the subscription, GSSM responds to Policy Enforcer indicating that the subscription is valid. At the same time, the Pepe's MSISDN is returned.
5. Digital Sport Newspaper service delivers the MMS from SportNews.com to Pepe through MMS enabler.
6. A response may be returned from Policy Enforcer to SportNews.com

B.10.7 Alternative Flow: Validation for an Anonymous User

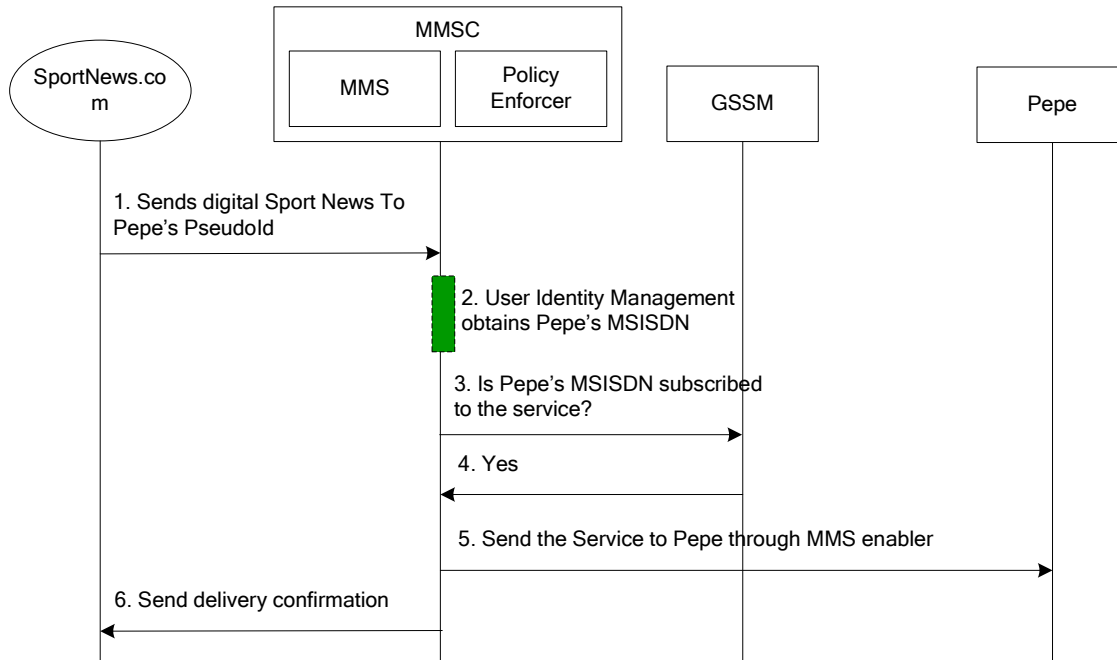

Figure 28: Service Validation for an Anonymous User (Alternative Flow)

1. The digital Sport Newspaper service application sends a MMS with the Sport content to Pepe. SportNews.com only knows the PseudoId as Pepe's Identity.
2. Policy Enforcer manages (itself or delegating to other resources) Pepe's identity and obtains Pepe's MSISDN.
3. Policy Enforcer sends a request to GSSM to verifying the validation of the subscription. The Policy Enforcer uses for this validation the MSISDN as User's identity.
4. After checking the subscription, GSSM responds to Policy Enforcer indicating that the subscription is valid.
5. Digital Sport Newspaper service delivers the MMS from SportNews.com to Pepe through MMS enabler.
6. A response may be returned from Policy Enforcer to SportNews.com

B.10.8 Operational and Quality of Experience Requirements

None

Appendix C. (Informative)

C.1 Compatibility with the service subscription data models widely used by OSS/BSS systems, and in particular the ones defined by TeleManagement Forum (SID)

The GSSM RD aims to specify the requirements for a general service subscription management function in compliance with Service Providers typically deployed infrastructures. This document has been elaborated paying a special attention to the specifications delivered by TeleManagement Forum, and more particularly the Shared Information/Data model (SID) which can be used as a reference for the organization of Services Preferences, Subscriptions data.

Independently of the existence (or not) in the network of a full NGOSS system compliant with TMF specifications and the SID model [TMF GB922v6], this document presents consolidated requirements for service subscription management function within the OMA context, and let freedom for implementation options.

For example in order to satisfy the requirements for dynamic manipulation of service subscription and service Subscription Validation, GSSM Enabler is expected to interface with entities like Subscribers data repository(ies), Charging (MCC Enabler) for credit-control, and the SID business entities (in the TMF model) or equivalent.

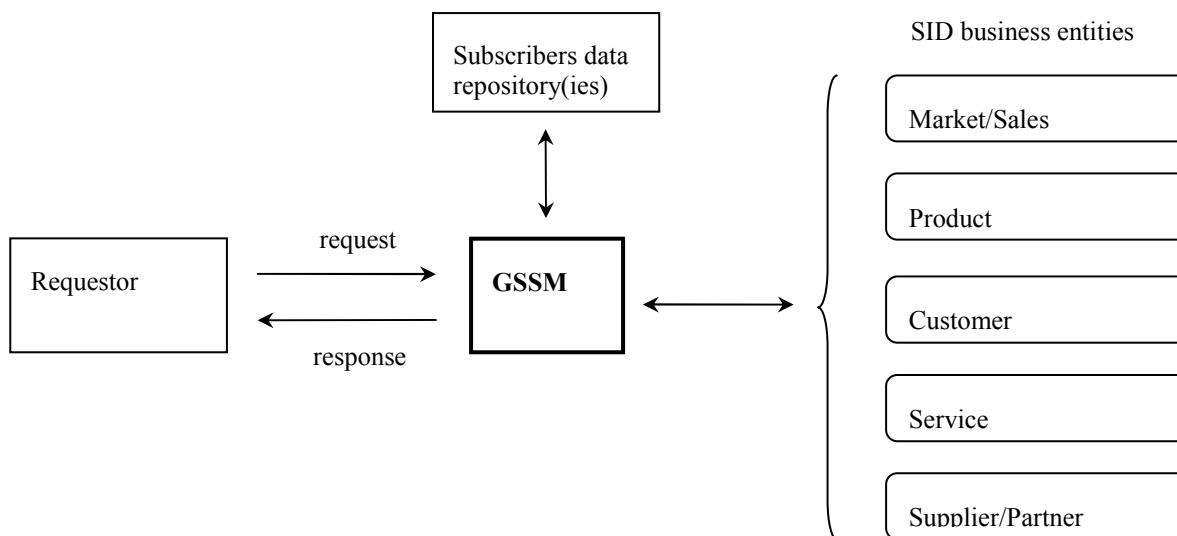

Figure 29: Key entities in the GSSM context

C.2 Compatibility with the User Profile and Subscription management models specified by 3GPP and ETSI TISPAN

The GSSM RD aims to specify the requirements for a general service subscription management function in compliance with Service Providers typically deployed infrastructures. This document has been elaborated paying a special attention to the specifications delivered by 3GPP (3rd Generation Partnership Project) and ETSI TISPAN, and more particularly the ones that relate to User Profile and Subscription management models.

3GPP reference specifications:

- TS 22.240: Service requirements for 3GPP Generic User Profile (GUP); Stage 1
- TS 23.240: 3GPP Generic User Profile (GUP) requirements; Architecture (Stage 2)
- TS 29.240: 3GPP Generic User Profile (GUP); Stage 3; Network
- TS 32.140: Telecommunication management; Subscription Management (SuM) requirements
- TS 32.141: Telecommunication management; Subscription Management (SuM) architecture

ETSI TISPAN reference specifications (all DRAFT only as of 06/2007):

- TS 188 002-1 ver. 0.0.10 (ref. DTS/TISPAN-08015-1-NGN-R2): NGN Subscription Management; Part 1: Requirements
- TS 188 002-2 ver. 0.0.5 (ref. DTS/TISPAN-08015-2-NGN-R2): NGN Subscription Management;; Part 2: Information Model
- TS 188 002-3 (ref. DTS/TISPAN-08015-3-NGN-R2): NGN Subscription Management; Part 3: Functional Architecture

The ETSI TISPAN relevant specifications are referenced here, although they are draft only and no versions have been approved so far, because they represent an attempt to enrich and generalize the 3GPP Subscription management related specifications for NGN (New Generation Networks). If published on time, these specifications may also be of use for GSSM Architecture Document (AD) elaboration.

Given the ETSI TISPAN specifications are currently in draft stage, we will use the 3GPP ones as reference for this appendix.

The key definitions for GSSM Enabler that relate to User Profile and Subscription management functions are: Subscriber, Subscription, Subscription Profile and User Profile. Subscription and Subscription Profile definitions used for GSSM are exactly identical with the 3GPP ones:

Subscription (both 3GPP and OMA definition): A subscription describes the commercial relationship between the subscriber and the service provider

Subscription Profile (both 3GPP and OMA definition): The set of information required for describing a service subscription, e.g. the subscriber identity, subscribed service, service preferences and/or service usage constraints.)

while for Subscriber and User Profile the differences between the definitions are minors:

Subscriber (3GPP definition): A Subscriber is an entity (e.g. a user) that is engaged in a Subscription with a service provider.

Subscriber (OMA Dictionary definition): A Subscriber is an entity (associated with one or more users) that is engaged in a Subscription with a service provider. The subscriber is allowed to subscribe and unsubscribe services, to register a user or a list of users authorised to enjoy these services, and also to set the limits relative to the use that associated users make of these services.

User Profile (3GPP definition): Is the set of information necessary to provide a user with a consistent, personalised service environment, irrespective of the user's location or the terminal used (within the limitations of the terminal and the serving network).

User Profile (OMA Dictionary definition): It is the set of information, including the user identity, personal information, personal preferences, necessary to provide a user with a consistent, personalised service environment,

irrespective of the user’s location or the terminal used (within the limitations of the terminal and the serving network).

Then 3GPP defines the notion of Service Preferences (Service Preferences: Contains the service preferences chosen for a user. Each user configures his preferences for a particular subscribed service, but only within the limits defined by the Subscription.), which GSSM defines using the term of Subscription Preferences (Subscription Preferences : Contains the service preferences chosen for a user. Each user configures his preferences for a particular subscribed service, but only within the limits defined by the Subscription. See [3GPP TS 32.141].), but with exactly the same definition.

Finally 3GPP defines the notion of Subscription Profile Component (Subscription Profile Component: discrete subset of the subscription profile that may be stored or managed separately from other subsets e.g. components that may be stored in different domains, subsystems or replicated using different synchronization rules.), while GSSM does not define or use such a notion.

The functional entities and actors belonging to 3GPP Subscription Management are described in Figure 30, extracted from TS 32.141.

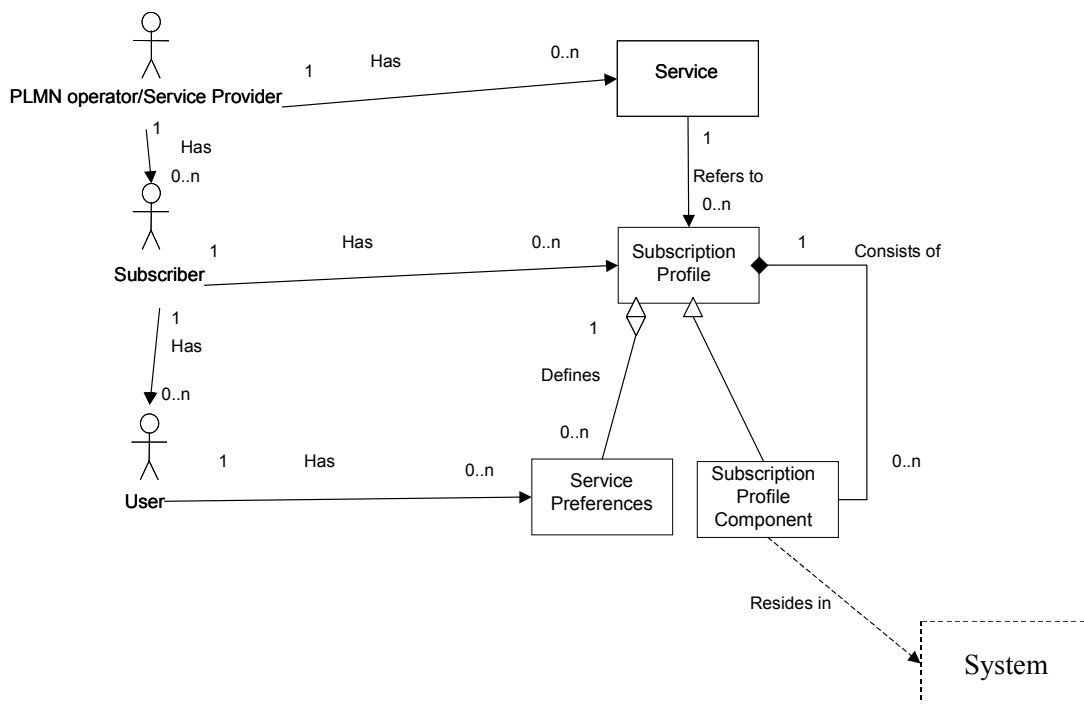

Figure 30: Functional entities and actors in 3GPP SuM

This model is identical to the one developed for GSSM Enabler and presented in section 4.2 Actors in the Context of GSSM, with the exception of the functional entity Subscription Profile Component that is not used by GSSM (this entity resides in the managed System in the 3GPP model).

Compared to 3GPP SuM, GSSM Enabler brings network independence for subscription management type of functions in OSE (OMA Service Environment).

3GPP has specified in its Release 6 Generic User Profile (GUP), with the objective to provide a conceptual description to enable harmonized usage of the user-related information located in different entities. Technically the 3GPP Generic User Profile provides an architecture, data description and interface with mechanisms to handle the data.

The GUP reference architecture as shown in Figure 31 consists of: GUP Server; Repository Access Function (RAF), GUP Data Repositories, Rg and Rp reference points, and Applications.

Figure 31 illustrates the GUP architecture as defined in 3GPP TS 23.240:

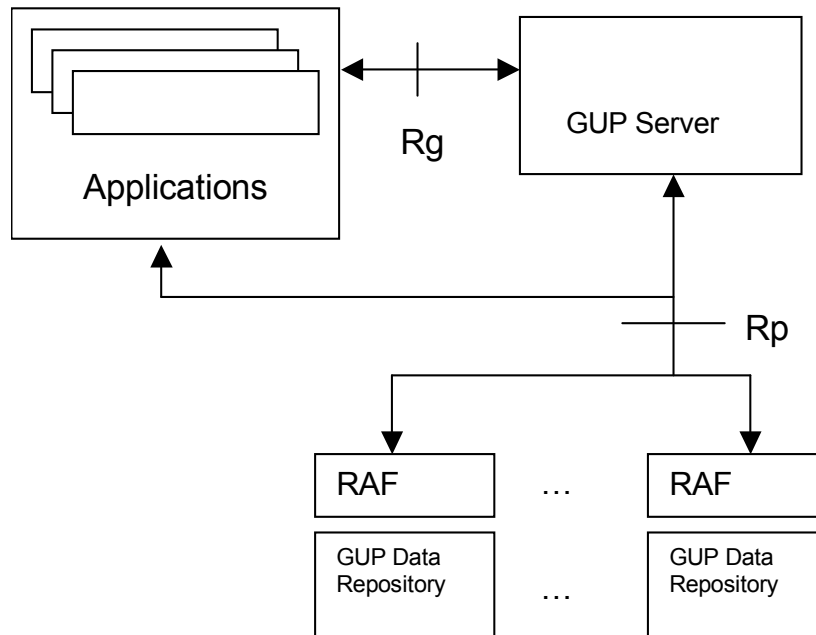

Figure 31: GUP Reference architecture

Two reference points, Rp and Rg, are exposed. Both Rp and Rg reference points allow applications to create, read, modify and delete any user profile data using the harmonized access interface, Rp providing a possible direct communication between application and GUP Data Repositories.

In the scenario of a required integration between GSSM and GUP, GSSM would therefore be positioned as a GUP “application”, leveraging as best as possible the availability of the Rg reference point., and using Rp direct access to data repositories when needed.

In addition, the functional comparison between 3GPP GUP and GSSM Enabler led to the following conclusions: in GUP there is no notion of: i) Subscription Validation, ii) subscription-related business validation, iii) Service Subscription Provisioning, iv) session management. Those notions are present in GSSM.

Some GSSM Subscription Profile management operations could be done using GUP, either using the Rp or Rg reference points, as explained above.