



Immersive Social Centre Requirements

Candidate Version 1.0 – 02 Apr 2013

Open Mobile Alliance
OMA-RD-ISC-V1_0-20130402-C

Use of this document is subject to all of the terms and conditions of the Use Agreement located at <http://www.openmobilealliance.org/UseAgreement.html>.

Unless this document is clearly designated as an approved specification, this document is a work in process, is not an approved Open Mobile Alliance™ specification, and is subject to revision or removal without notice.

You may use this document or any part of the document for internal or educational purposes only, provided you do not modify, edit or take out of context the information in this document in any manner. Information contained in this document may be used, at your sole risk, for any purposes. You may not use this document in any other manner without the prior written permission of the Open Mobile Alliance. The Open Mobile Alliance authorizes you to copy this document, provided that you retain all copyright and other proprietary notices contained in the original materials on any copies of the materials and that you comply strictly with these terms. This copyright permission does not constitute an endorsement of the products or services. The Open Mobile Alliance assumes no responsibility for errors or omissions in this document.

Each Open Mobile Alliance member has agreed to use reasonable endeavours to inform the Open Mobile Alliance in a timely manner of Essential IPR as it becomes aware that the Essential IPR is related to the prepared or published specification. However, the members do not have an obligation to conduct IPR searches. The declared Essential IPR is publicly available to members and non-members of the Open Mobile Alliance and may be found on the “OMA IPR Declarations” list at <http://www.openmobilealliance.org/ipr.html>. The Open Mobile Alliance has not conducted an independent IPR review of this document and the information contained herein, and makes no representations or warranties regarding third party IPR, including without limitation patents, copyrights or trade secret rights. This document may contain inventions for which you must obtain licenses from third parties before making, using or selling the inventions. Defined terms above are set forth in the schedule to the Open Mobile Alliance Application Form.

NO REPRESENTATIONS OR WARRANTIES (WHETHER EXPRESS OR IMPLIED) ARE MADE BY THE OPEN MOBILE ALLIANCE OR ANY OPEN MOBILE ALLIANCE MEMBER OR ITS AFFILIATES REGARDING ANY OF THE IPR'S REPRESENTED ON THE “OMA IPR DECLARATIONS” LIST, INCLUDING, BUT NOT LIMITED TO THE ACCURACY, COMPLETENESS, VALIDITY OR RELEVANCE OF THE INFORMATION OR WHETHER OR NOT SUCH RIGHTS ARE ESSENTIAL OR NON-ESSENTIAL.

THE OPEN MOBILE ALLIANCE IS NOT LIABLE FOR AND HEREBY DISCLAIMS ANY DIRECT, INDIRECT, PUNITIVE, SPECIAL, INCIDENTAL, CONSEQUENTIAL, OR EXEMPLARY DAMAGES ARISING OUT OF OR IN CONNECTION WITH THE USE OF DOCUMENTS AND THE INFORMATION CONTAINED IN THE DOCUMENTS.

© 2013 Open Mobile Alliance Ltd. All Rights Reserved.

Used with the permission of the Open Mobile Alliance Ltd. under the terms set forth above.

Contents

1. SCOPE (INFORMATIVE)	6
2. REFERENCES	7
2.1 NORMATIVE REFERENCES	7
2.2 INFORMATIVE REFERENCES	7
3. TERMINOLOGY AND CONVENTIONS	8
3.1 CONVENTIONS	8
3.2 DEFINITIONS	8
3.3 ABBREVIATIONS	8
4. INTRODUCTION (INFORMATIVE)	9
4.1 VERSION 1.0	9
5. ISC V1.0 RELEASE DESCRIPTION (INFORMATIVE)	10
5.1 END-TO-END SERVICE DESCRIPTION	11
6. REQUIREMENTS (NORMATIVE)	12
6.1 HIGH-LEVEL FUNCTIONAL REQUIREMENTS	12
6.1.1 Immersive Environment	12
6.1.2 Multi-Device Support	13
6.1.3 Social Interaction	13
6.1.4 Synchronization	14
6.1.5 Communication	15
6.1.6 Content Viewing Group	15
6.1.7 Management	16
6.1.8 Security	16
6.1.9 Charging Events	17
6.1.10 Administration and Configuration	17
6.1.11 Usability	17
6.1.12 Interoperability	18
6.1.13 Privacy	18
6.1.14 Interworking	18
6.2 OVERALL SYSTEM REQUIREMENTS	18
APPENDIX A. CHANGE HISTORY (INFORMATIVE)	19
A.1 APPROVED VERSION HISTORY	19
A.2 DRAFT/CANDIDATE VERSION 1.0 HISTORY	19
APPENDIX B. USE CASES (INFORMATIVE)	23
B.1 MULTI-DEVICE SUPPORT	23
B.1.1 Actors	23
B.1.2 Actor Specific issues	23
B.1.3 Actor Specific Benefits	23
B.1.4 Pre-conditions	23
B.1.5 Post-conditions	23
B.1.6 Normal Flow	23
B.1.7 Alternative Flow	24
B.1.8 Operational and quality of Experience Requirement	24
B.2 CONTENT VIEWING GROUP	24
B.2.1 Short Description	24
B.2.2 Actors	24
B.2.3 Actor Specific issues	25
B.2.4 Actor Specific Benefits	25
B.2.5 Pre-conditions	25
B.2.6 Post-conditions	25

- B.2.7 Normal Flow25
- B.2.8 Alternative Flow I.....25
- B.2.9 Alternative Flow II.....26
- B.2.10 Operational and quality of Experience Requirement26
- B.3 IMMERSIVE ENVIRONMENT26**
 - B.3.1 Actors.....26
 - B.3.2 Actor Specific issues.....26
 - B.3.3 Actor Specific Benefits26
 - B.3.4 Pre-conditions27
 - B.3.5 Post-conditions.....27
 - B.3.6 Normal Flow27
 - B.3.7 Alternative Flow27
 - B.3.8 Operational and quality of Experience Requirement27
- B.4 SYNCHRONIZATION.....27**
 - B.4.1 Short Description27
 - B.4.2 Actors.....27
 - B.4.3 Actor Specific issues.....28
 - B.4.4 Actor Specific Benefits28
 - B.4.5 Pre-conditions28
 - B.4.6 Post-conditions.....28
 - B.4.7 Normal Flow28
 - B.4.8 Operational and quality of Experience Requirement29

Figures

- Figure 1: The ISC Enabler – Actors and Roles..... 11**

Tables

- Table 1: High-Level Functional Requirements 12**
- Table 2: High-Level Functional Requirements – Immersive Environment..... 13**
- Table 3: High-Level Functional Requirements – Multi-Device Support 13**
- Table 4: High-Level Functional Requirements – Social Interaction 14**
- Table 5: High-Level Functional Requirements – Synchronization 14**
- Table 6: High-Level Functional Requirements – Communication..... 15**
- Table 7: High-Level Functional Requirements – Content Viewing Group 15**
- Table 8: High-Level Functional Requirements – Management..... 16**
- Table 9: High-Level Functional Requirements – Security 16**
- Table 10: High-Level Functional Requirements – Authentication..... 16**
- Table 11: High-Level Functional Requirements – Authorization 17**
- Table 12: High-Level Functional Requirements – Data Integrity 17**
- Table 13: High-Level Functional Requirements – Confidentiality..... 17**
- Table 14: High-Level Functional Requirements – Charging Events..... 17**
- Table 15: High-Level Functional Requirements – Administration and Configuration..... 17**

Table 16: High-Level Functional Requirements – Usability	18
Table 17: High-Level Functional Requirements – Interoperability	18
Table 18: High-Level Functional Requirements – Privacy	18
Table 19: High-Level Functional Requirements – Interworking	18
Table 20: Overall System Requirements	18

1. Scope

(Informative)

The Requirement Document (RD) contains the requirements for the Immersive Social Centre (ISC) Enabler. The aim is to comprise all requirements for a service-level framework to enable a standardized integration of content viewing and communication experience. This includes enhancing user experience with new features, the use of multiple devices (e.g. smartphones, TV, tablets, PC) in order to provide an immersive (“being there” and “being with”) experience.

High-level requirements and overall system requirements as well as several use cases which provide examples of ISC services that should be enabled are specified.

2. References

2.1 Normative References

- [RFC2119] “Key words for use in RFCs to Indicate Requirement Levels”, S. Bradner, March 1997,
[URL:http://www.ietf.org/rfc/rfc2119.txt](http://www.ietf.org/rfc/rfc2119.txt)

2.2 Informative References

- [OMA CPM] OMA Converged IP Messaging , Version 2.0, Open Mobile Alliance™,
[URL:http://www.openmobilealliance.org](http://www.openmobilealliance.org)
- [OMA DICT] “Dictionary for OMA Specifications”, Version 2.9, Open Mobile Alliance™,
OMA-ORG-Dictionary-V2_9, [URL:http://www.openmobilealliance.org/](http://www.openmobilealliance.org/)
- [OMA Privacy RD] “Privacy Requirements for Mobile Services”, Open Mobile Alliance™, OMA-RD-Privacy-V1_0,
URL: <http://www.openmobilealliance.org>
- [OMA SIMPLE IM] OMA SIMPLE IM , Version 2.0, Open Mobile Alliance™, [URL:http://www.openmobilealliance.org](http://www.openmobilealliance.org)

3. Terminology and Conventions

3.1 Conventions

The key words “MUST”, “MUST NOT”, “REQUIRED”, “SHALL”, “SHALL NOT”, “SHOULD”, “SHOULD NOT”, “RECOMMENDED”, “MAY”, and “OPTIONAL” in this document are to be interpreted as described in [RFC2119].

All sections and appendixes, except “Scope” and “Introduction”, are normative, unless they are explicitly indicated to be informative.

3.2 Definitions

Associated Contents	Various types of media content (such as text, static image, audio or video clips, etc.) used to provide enhancements or supplementary information to a main content being viewed.
Content Provider	See [OMA DICT].
Content View	A view showing an area of a physical place (e.g. concert) and provided to the end user.
Content Viewing Group	An ISC User group associated with a viewing content in which the Principals can share their Content Viewing Information.
Content Viewing Information	An information associated with a content being viewed (e.g., the content metadata) and related viewing progress (e.g., the content status, elapsed time).
Continuous Content View	A panoramic view formed by multiple Content Views that are ordered and adjacent with each other (e.g. “left”, “centre” and “right” views captured by different cameras).
ISC User	A user of a service that conforms to the ISC Enabler.
Non-ISC User	A user of a service that does not conform to the ISC Enabler.
Participant	See [OMA DICT].
Principal	See [OMA DICT].
Spatial Configuration	A setting that determines manually or automatically how incoming media streams are distributed to the end-user devices, e.g. based on user preferences, device capabilities, relative device positions.

3.3 Abbreviations

3D	Three Dimensions
CPM	Converged IP Messaging
EPG	Electronic Program Guide
HD	High Definition
IP	Internet Protocol
ISC	Immersive Social Centre
OMA	Open Mobile Alliance
PC	Personal Computer
SIMPLE IM	SIP for Instant Messaging and Presence Leveraging Extensions Instant Messaging
SIP	Session Initiation Protocol
TV	Television
URL	Uniform Resource Locator
VOD	Video On Demand

4. Introduction

(Informative)

For the last few years, there have been remarkable service trends in the mobile and/or television industry which suggest convergence of content viewing and communication, e.g. chatting with friends while watching a soccer match, searching through the web the biography of a celebrity appearing in an interview. Also it is evident that there is increasing user needs for more realistic (immersive) content, e.g. 3D, multi-view watching, telepresence.

However, there is little effort being done to integrate content viewing and communication experience in a cohesive manner and leveraging the immersive (“being-there” and “being-with”) experience in an integrated viewing and communication environment. Today there are standard and non-standard enablers for content distribution and communication but they exist in silos without interaction among them and the end user hardly gets the feel of immersive in the content being watched. With the advent of more versatile devices such as smartphones and tablets in addition to large display devices, it is even more challenging to discover the user environment at any given time and deliver the integrated content viewing and communication which gives the user a being-there and being-with experience.

The ISC Enabler provides a service-level framework (mainly leveraging SIP) to enable a standardization integration of content viewing and communication experience, including in a multiple devices environment, while providing an immersive experience. Such an experience can be applicable to various categories of events like leisure (sports, music), personal (weddings, birthdays, and anniversaries), organizational (seminars, conferences, product launch, trade fair), cultural (ceremonial, religious) etc.

The ISC User is expected to create and manage his/her Content Viewing Group and the ISC Users in the group are able to share their Content Viewing Group information. The ISC User in the same group can watch and discuss the viewing content together in his/her multiple device(s) and the watching content can be paused and resumed synchronously between all ISC Users in the group. In addition, the participant is allowed to invite other ISC Users for watching content together and the invited ISC User will be synchronized with the current watching content.

The environment that the ISC Enabler establishes is expected to support the ISC User to access the ISC-based service on his/her multi-device environment. The multiple devices of the ISC User will exchange their Content Viewing Information and synchronize the Content Viewing Information when watching content and communication are rendered on the different device(s). Namely, the ISC User will seamlessly access content viewing and communication across his/her multiple devices.

The ISC User is also expected to access the ISC-based service in the immersive environment, which allows the distribution of Content Views and/or Continuous Content Views based upon the Spatial Configuration. The ISC Enabler sets the distribution of incoming media streams to the ISC User’s device(s) based on user preferences and device capabilities, relative devices positions and symmetric/asymmetric devices placement. As a result of Spatial Configuration, both ISC Users will have an immersive social communication as if there have a ‘being-there’ and/or ‘being-with’ experience like telepresence.

As one of the social communication Enablers, the ISC Enabler is expected for the ISC Users to support watching the same content at the same time and synchronizing the same views when available. After establishing the communication session between the ISC Users, An ISC User can also start synchronization with the Content View of the other ISC User by sending a request to watch together. As a result of this operation, ISC Users will be in the same content while watching content and discuss the content together. If an ISC User doesn’t want to watch the same Content View, the ISC User can make a request to stop synchronizing with the other’s Content View and watch the different content while remaining in the same communication session.

The ISC Enabler will re-use as appropriate (e.g. through reference) relevant parts of the associated supporting specifications.

4.1 Version 1.0

The version 1.0 of the ISC Enabler defines a framework that enables a standardized integration of content viewing and communication experience.

The core functionalities exposed by the ISC Enabler include: immersive content viewing environment, multi-device support, synchronization, social interaction and management, social communication capabilities, security and privacy aspects.

This version of the ISC Enabler covers the requirements marked as ISC V1.0 in the tables in Section 6.

5. ISC V1.0 release description (Informative)

The ISC Enabler provides common building blocks, by reuse of existing blocks and by defining new ones, to allow for consolidation of both content viewing and interactive content, interpersonal multimedia communication services in a cohesive manner within single or multi-devices environment which accommodate different user experiences such as immersivity (“being-there” and “being-with” experiences), contextual presence exchange, supplementary data sharing.

Some of the items supported in this release are:

The ISC Enabler supports interactivity with the content and one-to-one and one-to-many interpersonal multimedia communication from within the associated content viewing.

The ISC Enabler supports the creation of services that allow ISC Users to:

- do content viewing and communication (e.g., send invitation, post comments) with other users in parallel;
- synchronize their content view with other user(s);
- share information of their content viewings (e.g., content name, same view or not) and presence information (e.g. available/not available for content viewing);
- get list of contents (personalized) available for viewing along with metadata and preview of the content;
- receive content views according to published device capability and spatial configuration;
- concurrently associate several devices with themselves;
- interact with the content (e.g., voting, delegate content viewing rights);
- personalise their services by setting preferences;
- store content viewed and associated communication in the device(s) and/or network.

The following figure shows the actors and their roles for the ISC Enabler.

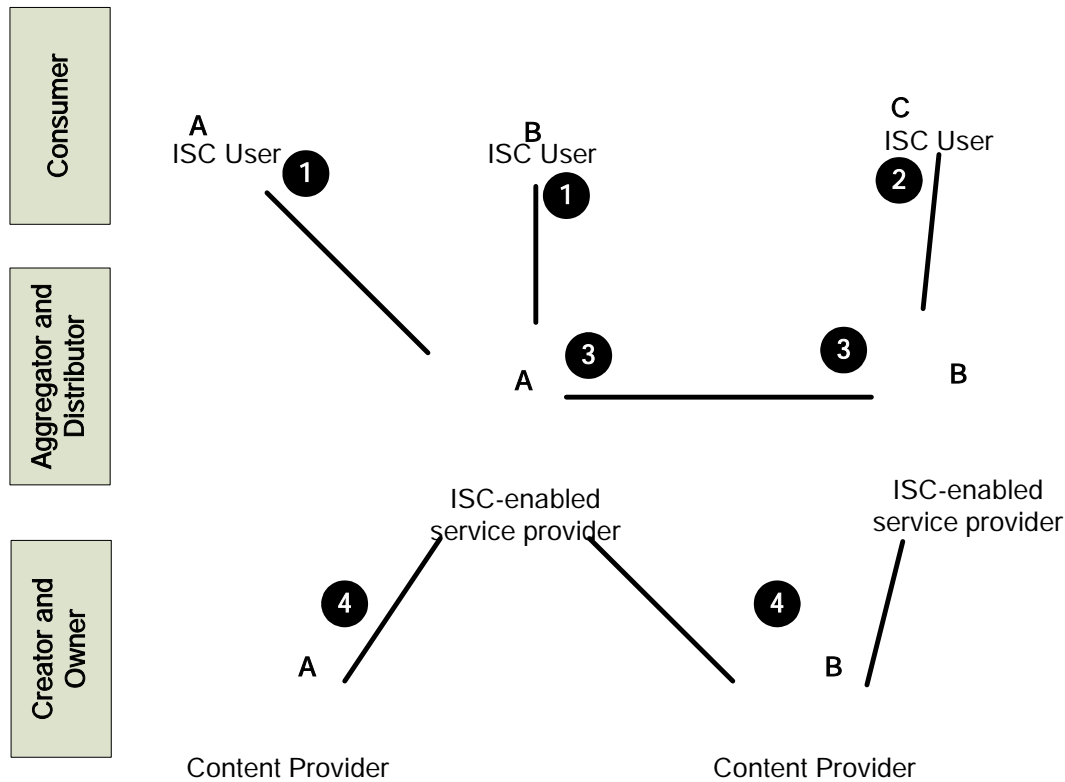

- 1 ISC User - uses ISC-Enabled service in his/her home domain
- 2 ISC-enabled service provider - offers ISC-enabled services to its subscribers
- 3
- 4 Content Provider - offers contents to ISC Users via ISC-enabled service provider

Figure 1: The ISC Enabler – Actors and Roles

5.1 End-to-end Service Description

Users have needs to share their experience with their family, friends, and other contacts. To represent many kinds of experience, users may use different kinds of method such as sharing photos, commenting through the diverse social networks, sending short message through instant messagings, or talking directly with their friends through call services.

However, as of now, users can share their experience only after they experience something, even more sharing activities are dependent on their sharing methods.

The OMA ISC Enabler provides a wide range of functionalities to support converged experience-sharing services before or after they experience something, services including instant messaging, multimedia content delivery and sharing, video call during the content viewing, and interaction with broadcasting services.

6. Requirements (Normative)

6.1 High-Level Functional Requirements

Label	Description	Release
ISC-HLF-001	The ISC Enabler SHALL enable ISC User to get the list of contents (including other ISC User generated and published live/non-live audio/video) available for viewing including the content metadata information, subject to the service provider policy.	ISC V1.0
ISC-HLF-002	The ISC Enabler SHALL, based on user preferences and the service provider policy, automatically or on request personalize (based on similarity of content, ISC User history of viewing, capability of devices etc) the list of contents available to ISC User.	ISC V1.0
ISC-HLF-003	The ISC Enabler SHALL enable the ISC User to fetch content(s) and/or preview of the content(s) when available, subject to the service provider policy.	ISC V1.0
ISC-HLF-004	The ISC Enabler SHALL support authorized Principals (e.g., ISC User, service provider) to search for ISC Users based on allowed criteria for content (such as content name, content identifier, pre-defined keyword, bookmarks, content tags of the content being viewed or interested content) in a service provider's domain, subject to the service provider policy.	ISC V1.0
ISC-HLF-005	The ISC Enabler SHALL support authorized Principals (e.g., ISC User, service provider) to search for content(s) based on allowed criteria (such as content name, content identifier, pre-defined keyword, bookmarks, content tags, viewed/viewing content, rating comment) in a service provider's domain, subject to the service provider policy.	ISC V1.0
ISC-HLF-006	The ISC Enabler SHALL, upon subscription request from ISC User, provide support to send notifications to his/her when there is a match in her/her notification criteria (e.g., other ISC Users watching or indicating interest to watch the same content, other ISC Users have bookmarked content at same position in the content), subject to the service provider policy.	ISC V1.0
ISC-HLF-007	The ISC Enabler SHALL support ISC Users, individually or along with other ISC User (s), to request a new content which is not available among the list of contents.	ISC V1.0
ISC-HLF-008	The ISC Enabler SHALL support both live and VOD content for ISC User to experience on the ISC User's device.	ISC V1.0
ISC-HLF-009	The ISC Enabler SHALL allow the ISC User to start viewing a content from a position indicated by another ISC User.	ISC V1.0

Table 1: High-Level Functional Requirements

6.1.1 Immersive Environment

Label	Description	Release
ISC-IMM-001	The ISC Enabler SHALL support publishing, discovering and utilizing ISC User's device capability (including spatial relationship with other devices, location, orientation) according to the user preferences and the service provider policy.	ISC V1.0
ISC-IMM-002	The ISC Enabler SHALL support distribution of Content Views according to Spatial Configuration of the originating ISC Users/Content Provider and receiving ISC Users devices in a 1-1 or 1-N content viewing session.	ISC V1.0
ISC-IMM-003	The ISC Enabler SHALL support distribution of Continuous Content Views according to Spatial Configuration of the originating ISC Users/Content Provider and receiving ISC Users devices (e.g. "left" Content View distributed to the left-positioned device).	ISC V1.0
ISC-IMM-004	The ISC Enabler SHALL support distribution of the ISC User(s) communication media (e.g., audio/video call) to/between ISC Users according to Spatial Configuration of their devices.	ISC V1.0

ISC-IMM-005	The The ISC Enabler SHALL support redistribution of Content Views and Continuous Content Views according to any modified Spatial Configuration of the originating ISC Users/Content Provider and receiving ISC Users devices.	ISC V1.0
ISC-IMM-006	The ISC Enabler SHALL support collecting and publishing ISC User's Content View selection (such as list of available Content Views, current ISC User's field of view or viewing distance) according to the user preferences and the service provider policy.	ISC V1.0
ISC-IMM-007	The ISC Enabler SHALL support selecting and rendering of Content Views and Continuous Content Views according to the Content View selection of the ISC User.	ISC V1.0
ISC-IMM-008	The ISC Enabler SHALL support reselecting and rendering of Content Views and Continuous Content Views according to any modified Content View selection of the ISC User (e.g. produce and deliver another Content View according to the modified field of view).	ISC V1.0

Table 2: High-Level Functional Requirements – Immersive Environment

6.1.2 Multi-Device Support

Label	Description	Release
ISC-MDS-001	The ISC Enabler SHALL allow the ISC User in heterogeneous multi-device environment (e.g., on mobile, tablets, television, large displays) to manage his/her content viewing and communication, e.g., viewing content on television and communicating by mobile.	ISC V1.0
ISC-MDS-002	The ISC Enabler SHALL provide the capabilities to synchronize Content Viewing Information between multi-devices of the same ISC User when content viewing and communication being distributed on different ISC enabled devices.	ISC V1.0
ISC-MDS-003	The ISC Enabler SHALL allow ISC User's device to discover capabilities (e.g. display resolution, codecs, IP address) of the other device(s) in his/her heterogeneous multi-device environment.	ISC V1.0
ISC-MDS-004	The ISC Enabler SHALL provide the capabilities to allow the ISC User to share the content metadata and/or associated content information (e.g. content status, content related information such as URL, EPG, or profiles of actors) between his/her device(s) in heterogeneous multi-device environment, subject to the service provider policy.	ISC V1.0
ISC-MDS-005	The ISC Enabler SHALL be able to deliver media contents (owned by the Content Provider or published by other ISC Users) requested by the ISC User to one or more of his/her devices, based on his/her device capabilities.	ISC V1.0

Table 3: High-Level Functional Requirements – Multi-Device Support

6.1.3 Social Interaction

Label	Description	Release
ISC-SOC-001	The ISC Enabler SHALL support social activity (e.g. send invitation, request to join, content sharing) between ISC Users, subject to the user preferences and the service provider policy.	ISC V1.0
ISC-SOC-002	The ISC Enabler SHALL support unidirectional/bidirectional social interaction between the ISC User and the Content Provider (e.g. transmitting vote of the ISC User to the presenter of a TV show) according to the users preferences and the service provider policy.	ISC V1.0
ISC-SOC-003	The ISC Enabler SHALL allow the ISC User to delegate his/her content viewing rights to other ISC Users subject to the service provider policy.	ISC V1.0
ISC-SOC-004	The ISC Enabler SHALL allow an ISC User, if authorized, to retrieve another ISC User's presence information (e.g. available/not available for content viewing), subject to the user preferences and service provider policy.	ISC V1.0

ISC-SOC-005	The ISC Enabler SHALL allow the ISC User to establish a social relationship (e.g. setting up the ISC User as 'colleague', 'friend' etc) with other ISC User(s), subject to the user preferences and service provider policy.	ISC V1.0
ISC-SOC-006	The ISC Enabler SHALL enable the ISC User to share information related to his/her experience with content (such as interest to watch a content, watched a content, bookmarks, content tags, comments of the viewing/viewed content) with other ISC User(s), subject to the user preferences and service provider policy.	ISC V1.0
ISC-SOC-007	The ISC Enabler SHALL support an ISC User to share his/her generated content (e.g., audio/video) which can be made available live/non-live to other ISC Users by the service provider, subject to the service provider policy.	ISC V1.0
ISC-SOC-008	The ISC Enabler SHALL support an authorized Principal (e.g. ISC User, ISC service provider) to obtain shared information related to other ISC User(s) experience with content (e.g., interest to watch a content, bookmarks, content tags, ISC User published live/non-live audio/videos, comments) , subject to the user preferences and service provider policy.	ISC V1.0
ISC-SOC-009	The ISC Enabler SHALL provide the capabilities to allow the ISC User to manage (e.g. create, modify, delete) information (e.g. metadata, bookmarks, content tags) related to the viewing/viewed content, subject to the user preferences and the service provider policy.	ISC V1.0
ISC-SOC-010	The ISC Enabler SHALL allow an ISC User to receive suggestions of other ISC Users and/or suggestions of contents from the service provider, relevant to ISC User activity (e.g., suggestions of ISC Users to watch the content together, suggestions of the content) subject to the user preferences and the service provider policy.	ISC V1.0
ISC-SOC-011	The ISC Enabler SHALL be able to support the ISC User to establish (non-realtime) communication channel via the service provider to allow other ISC Users to communicate with e.g., ISC User can create a new topic to receive ISC User comments.	ISC V1.0
ISC-SOC-012	The ISC Enabler SHALL support the ISC User to express interest (e.g., Like) on a comment and/or content provided by the service provider or other ISC User(s).	ISC V1.0
ISC-SOC-013	The ISC Enabler SHALL provide the capabilities to allow ISC Users sharing their Content Viewing Information and communication information (e.g. list of ISC Users communicating while watching the same content), e.g., on ISC User's addressbook, subject to the user preferences and the service provider policy.	ISC V1.0
ISC-SOC-014	The ISC Enabler SHALL enable ISC Users to provide feedback to the content viewed such as a rating and comment.	ISC V1.0

Table 4: High-Level Functional Requirements – Social Interaction

6.1.4 Synchronization

Label	Description	Release
ISC-SYN-001	The ISC Enabler SHALL enable ISC User to request and receive information about another ISC User's context (e.g., same Content View or not, Content View changed) of the content being viewed subject to the service provider policy.	ISC V1.0
ISC-SYN-002	The ISC Enabler SHALL support the ISC Users (e.g., based on that ISC User request) to share his/her context (e.g., same Content View or not, Content View changed) of the content being viewed for synchronization to other ISC User(s), subject to the users preferences and the service provider policy.	ISC V1.0
ISC-SYN-003	The ISC Enabler SHALL support an ISC User to invite another ISC User to synchronize his/her Content View to the Content View of the inviting ISC User.	ISC V1.0
ISC-SYN-004	The ISC Enabler SHALL support an ISC User to request synchronizing the Content View of the content he/she is watching to that of another ISC User.	ISC V1.0
ISC-SYN-005	The ISC Enabler SHALL support an ISC User to request synchronizing his/her Content View of the content being watched to that of another ISC User.	ISC V1.0

Table 5: High-Level Functional Requirements – Synchronization

6.1.5 Communication

Label	Description	Release
ISC-COM-001	The ISC Enabler SHALL support the ISC User to use multimedia, such as text/image/audio/video/HD-video in 1-1 and 1-N communication with other ISC User(s), subject to their communication capabilities and the service provider policy.	ISC V1.0
ISC-COM-002	The ISC Enabler SHALL allow the authorised ISC User to share whole or parts of the content (e.g., audio/video) and/or references to whole or parts of the content in 1-1 and 1-N communication with other ISC User(s), subject to the service provider policy.	ISC V1.0
ISC-COM-003	The ISC Enabler SHALL allow the authorized ISC User to create and manage the established communication session (e.g. manage floor control) based upon the service provider policy.	ISC V1.0
ISC-COM-004	The ISC Enabler SHALL allow the ISC User or Content Provider to start communication (e.g. voice/video call with a presenter or participants in a TV show) to each other, e.g. when the ISC User views the Content Provider's content, subject to the user preferences and the service provider policy.	ISC V1.0

Table 6: High-Level Functional Requirements – Communication

6.1.6 Content Viewing Group

Label	Description	Release
ISC-CVG-001	The ISC Enabler SHALL support an authorized Principal (e.g. the ISC User, service provider) to manage his/her Content Viewing Group, e.g., creating group, deleting group, inviting participants, removing participants, processing join requests, and setting group policy.	ISC V1.0
ISC-CVG-002	The ISC Enabler SHALL support the participants in a Content Viewing Group to share their Content Viewing Information, according to the user preferences and the service provider policy.	ISC V1.0
ISC-CVG-003	The ISC Enabler SHALL support the authorized Principals (e.g., ISC User, service provider) to search for Content Viewing Group(s) based on criteria for content being viewed (such as content name, content identifier, pre-defined keyword) in a service provider's domain, subject to the service provider policy.	ISC V1.0
ISC-CVG-004	The ISC Enabler SHALL support the authorized Principals (e.g., ISC User, service provider) to simultaneously pause and resume the content viewing of all the members in the Content Viewing Group subject to the service provider policy and group policy.	ISC V1.0
ISC-CVG-005	The ISC Enabler SHALL support the ISC User to resume his/her previous content viewing, previously paused manually or automatically due to new content viewing (e.g. when joining a Content Viewing Group), subject to the user preferences and the service provider policy.	ISC V1.0
ISC-CVG-006	The ISC Enabler SHALL support the ISC User's activities related to participation in a Content Viewing Group (e.g., to accept invitation to join into the group, to initiate request to join into the group, to join into and/or to leave from the group), subject to the user preference and the service provider policy.	ISC V1.0
ISC-CVG-007	The ISC Enabler SHALL, upon the subscription request from the ISC User, provide support to send notifications about Content Viewing Groups e.g. start watching a content, when there is match in notification criteria (such as content name, content identifier, pre-defined keyword), subject to the service provider policy.	ISC V1.0

Table 7: High-Level Functional Requirements – Content Viewing Group

6.1.7 Management

Label	Description	Release
ISC-MAN-001	The ISC Enabler SHALL support the ISC User to store and manage (retrieve, delete, share, etc) his/her viewed contents, Content Viewing Information, and communication data (e.g. chat content between ISC Users) locally in his/her device(s) and/or network repository, subject to the rights policy of the viewed content, as provided by the service provider.	ISC V1.0
ISC-MAN-002	The ISC Enabler SHALL support the ISC User to manage (e.g. retrieve, store, distribute to a secondary device) Associated Contents of content viewing (e.g. associated profile of a player being displayed in a primary content), received from the ISC service provider or other ISC Users, subject to the user preferences and the service provider policy.	ISC V1.0
ISC-MAN-003	The ISC Enabler SHALL support storing ISC User's Content Viewing Information automatically at certain time intervals according to the user preferences and the service provider policy, and depending on the content rights policy of the viewing content.	ISC V1.0
ISC-MAN-004	The ISC Enabler SHALL support an ISC User to resume his/her content viewing, if available, from any of the ISC User's capable devices.	ISC V1.0
ISC-MAN-005	The ISC Enabler SHALL support the ISC User to manage his/her user preferences.	ISC V1.0

Table 8: High-Level Functional Requirements – Management

6.1.8 Security

Label	Description	Release
ISC-SEC-001	The ISC Enabler SHALL provide a mechanism to protect ISC User from receiving an unwanted message (by the recipient), according to the user preferences (e.g., black list, block advertisements) and the service provider policy.	ISC V1.0
ISC-SEC-002	The ISC Enabler SHALL provide capabilities of content screening (e.g., blocking, allowing, or amending content) prior to delivery of the content to the ISC User, according to the service provider policy.	ISC V1.0
ISC-SEC-003	The ISC Enabler SHALL provide a security mechanism to deny access by unauthorized Principals.	ISC V1.0
ISC-SEC-004	The ISC Enabler SHALL support a security mechanism to preserve the integrity and confidentiality of communication and content viewing when the ISC User accesses the ISC network-based functionality.	ISC V1.0

Table 9: High-Level Functional Requirements – Security

6.1.8.1 Authentication

Label	Description	Release
ISC-AUC-001	The ISC Enabler SHALL support a Principal to be authenticated by the service provider's domain.	ISC V1.0
ISC-AUC-002	The ISC Enabler SHALL support a Principal to authenticate the service provider's domain.	ISC V1.0
ISC-AUC-003	The ISC Enabler MAY leverage the authentication capabilities of the underlying IP network to authenticate a Principal.	ISC V1.0
ISC-AUC-004	The ISC Enabler MAY leverage the authentication capabilities of the underlying IP network to allow a Principal to authenticate the service provider's domain.	ISC V1.0

Table 10: High-Level Functional Requirements – Authentication

6.1.8.2 Authorization

Label	Description	Release
ISC-AUT-001	The ISC Enabler SHALL verify, if applicable by the service provider policy, whether a Principal is authorized to perform the action(s) it requested.	ISC V1.0
ISC-AUT-002	The ISC Enabler MAY provide a mechanism to prevent unauthorized access to an ISC User's related contents/information stored on his/her device(s) (e.g. lost or stolen device).	ISC V1.0
ISC-AUT-003	The ISC Enabler SHALL prevent unauthorized access to ISC User's related contents/information stored in the network.	ISC V1.0
ISC-AUT-004	The ISC Enabler SHALL support the ISC User to manage authorisation rules (e.g. to retrieve/search/modify the ISC User's published contents) that allow others to obtain information from his/her published contents.	ISC V1.0
ISC-AUT-005	The ISC Enabler SHALL support the ISC User to manage default authorization rule to be applied to any ISC User that are not explicitly identified within the authorization rules.	ISC V1.0

Table 11: High-Level Functional Requirements – Authorization

6.1.8.3 Data Integrity

Label	Description	Release
ISC-INT-001	The ISC Enabler SHALL ensure data integrity of the ISC User's data (e.g. content viewing, communication).	ISC V1.0

Table 12: High-Level Functional Requirements – Data Integrity

6.1.8.4 Confidentiality

Label	Description	Release
ISC-CON-001	The ISC Enabler SHALL support confidentiality of data (e.g., content, communication) exchange.	ISC V1.0

Table 13: High-Level Functional Requirements – Confidentiality

6.1.9 Charging Events

Label	Description	Release
ISC-CHG-001	The ISC Enabler MAY support a set of charging events to support various business models.	ISC V1.0

Table 14: High-Level Functional Requirements – Charging Events

6.1.10 Administration and Configuration

Label	Description	Release
ISC-ADM-001	The ISC Enabler SHALL provide a mechanism for remote provisioning and configuration of the ISC User's device(s).	ISC V1.0

Table 15: High-Level Functional Requirements – Administration and Configuration

6.1.11 Usability

Label	Description	Release
ISC-USA-001	The ISC Enabler SHALL allow the ISC User to control (e.g. start, stop) the content viewing delivered by the Content Provider.	ISC V1.0

ISC-USA-002	The ISC Enabler SHALL support the ISC User to get information associated with the viewing/viewed content (e.g., current watchers number, trends, hot topics, bookmarks, content tags, location and popularity), subject to the user preferences and the service provider policy.	ISC V1.0
ISC-USA-003	The ISC Enabler SHALL support the ISC User to provide information associated with the viewing/viewed content (e.g. comment about the content, voting, photo of the ISC User or respond to a survey from the service provider), subject to the user preferences and the service provider policy.	ISC V1.0
ISC-USA-004	The ISC Enabler SHALL allow the ISC User to request a content to be delivered at a later time, subject to the service provider policies.	ISC V1.0
ISC-USA-005	The ISC Enabler SHALL allow the ISC User to request to get one or more notifications (e.g. alert signal 10 minutes before the distribution of the content starts), to himself/herself and/or to a group of ISC Users, about a content he/she selected to watch, but which is scheduled to be shown at a later time.	ISC V1.0
ISC-USA-006	The ISC Enabler SHALL support sending notifications to the ISC User's device(s) about a content he/she selected to watch before the distribution of the content starts, if the notification was previously requested by the ISC User.	ISC V1.0

Table 16: High-Level Functional Requirements – Usability

6.1.12 Interoperability

Label	Description	Release
ISC-INT-001	The ISC Enabler SHALL be able to support content viewing and communication among ISC Users from different service providers	ISC V1.0

Table 17: High-Level Functional Requirements – Interoperability

6.1.13 Privacy

Label	Description	Release
ISC-PRV-001	The ISC Enabler SHALL provide mechanisms to protect privacy of ISC Users, e.g. based on requirements specified in [OMA Privacy RD].	ISC V1.0

Table 18: High-Level Functional Requirements – Privacy

6.1.14 Interworking

Label	Description	Release
ISC-IWG-001	The ISC Enabler SHALL support interworking capabilities for an ISC User to communicate with Non-ISC Users (e.g. OMA SIMPLE IM, OMA CPM users) subject to the service provider policy.	ISC V1.0

Table 19: High-Level Functional Requirements – Interworking

6.2 Overall System Requirements

Label	Description	Release
ISC-OSR-001	Recognizing the existence of current standards-based communication services and multimedia services, the ISC Enabler SHOULD re-use as appropriate (e.g. through reference) relevant parts of the associated supporting specifications.	ISC V1.0

Table 20: Overall System Requirements

Appendix A. Change History

(Informative)

A.1 Approved Version History

Reference	Date	Description
n/a	n/a	No prior version

A.2 Draft/Candidate Version 1.0 History

Document Identifier	Date	Sections	Description	
Draft Versions OMA-RD-ISC-V1_0	05 Jul 2012	All	Baseline as agreed in: OMA-COM-ISC-2012-0001-INP_ISC_v1.0_RD_Baseline	
	16 Jul 2012	Section 6.1	Added a HLF requirement on sharing content viewing information (CR#2012-0002R01) Added two HLF requirements for support of multi-device environment (CR#2012-0003R03) Added a HLF requirement on the storage and management of the viewed contents and communication (CR#2012-0004R01) Added a HLF requirement on the management of associated contents of content viewing and a HLF requirement for support of social activity (CR#2012-0011R02) Added two HLF requirements for support of the group communications (CR#2012-0006R02)	
		Section 6.1.4	Added two Usability requirements on streaming content management (CR#2012-0013R03)	
		Section 6.1.7	Added a new section 6.1.7 and added one requirement about delegation of content viewing rights between users (CR#2012-0007R01)	
		Section 6.1.8	Added a new section 6.1.8 and added three requirements for support of spatial features (CR#2012-0008R02)	
		Section 6.1.9	Added a new section 6.1.9 and added four requirements about synchronized viewing (CR#2012-0010R01)	
		Section 6.1.10	Added a new section 6.1.10 and added two requirements about user interaction (CR#2012-0012R03)	
		Section 6.1.11	Added a new section 6.1.11 and added one requirement about communication (CR#2012-0014R03)	
		Section 6.1.12	Added a new section 6.1.12 and added one requirement about user participation (CR#2012-0017R03)	
		30 Jul 2012	Section 6.1 & its sub-sections	Restructured of section 6.1 and re-located of the agreed requirement (INP#2012-0021)
		19 Sep 2012	Section 6.1	Updated one requirement HLF-001 (CR#2012-0030R01) Added three new high-level requirements about content list (CR#2012-0031R02) Added one new requirement about comment and feedback (CR#2012-0050R01)
	Section 3.2 Section 6.1.1		Added three new definitions to section 3.2, and added two new requirements and updated two agreed requirements about immersive environment (CR#2012-0029R02)	
	Section 3.3 Section 6.1.1		Added one abbreviation to section 3.3 and added two new requirements about live and VOD content (CR#2012-0047R01)	
	Section 6.1.2		Added two new requirements to section 6.1.2 about multi-device support (CR#2012-0033R03)	
	Section 6.1.3		Added a new requirement about presence information (CR#2012-0024R03) Added two new requirements about auxiliary session support (CR#2012-0032R01) Added a missed agreed requirement about user interaction (CR#2012-0034R01) Added a new requirement about social relationship (CR#2012-0035R01)	
	Section 6.1.5		Updated requirement COM-001 (CR#2012-0025R02)	

Document Identifier	Date	Sections	Description
		Section 2.2 Section 3.3 Section 6.1.6	Updated the reference of OMADICT, and added two definitions, and added a new requirement about content viewing group searching (CR#2012-0026R03)
		Section 6.1.7	Updated one requirement MAN-001 about management (CR#2012-0036R02) Added one new requirement about management (CR#2012-0045R01) Added one new requirement about resuming content viewing (CR#2012-0052R01)
		Section 6.1.8	Added two new requirements about unwanted messages and content screening (CR#2012-0027R03) Added two new requirements about authorized access (CR#2012-0037R02)
		Section 6.1.8.1	Added four new requirements about authentication (CR#2012-0038R01)
		Section 6.1.8.2	Added five new requirements about authorization (CR#2012-0039R02)
		Section 6.1.8.3	Added one new requirement about data integrity (CR#2012-0040R02)
		Section 6.1.9	Added one new requirement about charging events (CR#2012-0041R01)
		Section 6.1.10	Added one new requirement about administration and configuration (CR#2012-0042R02)
		Section 6.1.11	Added a new requirement about active information (CR#2012-0028R02) Added a new requirement about active information (CR#2012-0053R01)
		Section 6.1.12	Added one new requirement about interoperability (CR#2012-0043R02)
		Appendix B	Added a new use case about content viewing group (CR#2012-0022R04) Added a new use case about multi-device support (CR#2012-0023R04)
	24 Sep 2012	Section 6.1.3	Updated a mistake of incorporating two unagreed requirements from a noted contribution (CR#2012-0032R01). The operation is deleting the two requirements and updating the label of the original followed agreed requirement.
	17 Oct 2012	Section 1 Section 3.2 Section 6.1 Section B.2	Updated the scope description of the RD (CR#2012-0054R01) Added three new definitions and updated the relevant requirements (CR#2012-0056R01)
		Section 6.2	Added a new overall system requirement (CR#2012-0057R01)
	31 Oct 2012	Section 4	Added the Introduction (CR#2012-0062R01)
		Section 5	Added the Release Description (CR#2012-0063R01)
	7 Nov 2012	Section 6.1.6, Appendix B.2	Added two new requirements and updated a use case about content viewing group (CR#2012-0061R02)
		Section 6.1.6	Added a new requirement and updated the requirement ISC-CVG-001 about content viewing group (CR#2012-0072R01)
	16 Nov 2012	All	Deleted all comments from OMA RD template, and deleted empty tables (and columns) (CR#2012-0067R01)
		Section 4.1	Added description to release version 1.0 (CR#2012-0090R01)
		Section 5	Added a figure to the Release Description (CR#2012-0074R02)
		Section 5.1	Added end-to-end service description (CR#2012-0099R01)
		Section 6.1	Added two new requirements on searching for content and user (CR#2012-0079R01) Added two new requirements on searching for notification (CR#2012-0081R02) Added a new requirement on content list (CR#2012-0093) Updated requirement HLF-004 (CR#2012-0094)
		Section 6.1.1	Added three new requirements on immersive environment (CR#2012-0088R01) Updated requirement IMM-001 (CR#2012-0096R01)

Document Identifier	Date	Sections	Description
		Section 6.1.3	Added three new requirements on publishing information (CR#2012-0080R02) Added a new requirements on information management (CR#2012-0084R02) Added a new requirement on suggestion (CR#2012-0100R01)
		Section 6.1.4	Added one requirements on synchronization and a new Editor Note (CR#2012-0078R02) Updated requirements for Content View (CR#2012-0098R01)
		Section 6.1 Section 6.1.5	Added a new requirement on communication and updated requirement HLF-002 (CR#2012-0082R01) Added two new requirement on suggestions (CR#2012-0083R03)
		Section 6.1.7	Added a new requirement on user preference management (CR#2012-0097R01)
		Section 6.1.11	Added three new requirements on Usability (CR#2012-0076R02)
		Section B	Added a new use case for immersive environment (CR#2012-0086R02) Added a new use case on synchronization (CR#2012-0095R01)
	09 Jan. 2013	All	Updated the whole document with editorial changes from the Editor's perspective (CR#2012-0108R01)
		Section 4.1 Section 5	Updated the descriptions of version and release (CR#2013-0001R01)
		Section 6.1	Updated the requirement ISC- HLF-005 (CR#2013-0002R01)
		Section 6.1 Section 6.11	Updated the requirement ISC-IMM-008 and moved the requirements ISC-IMM-009 and ISC-IMM-010 to section 6.1 (CR#2013-0003R02)
	24 Jan. 2013	Section 6.1	Updated the requirement ISC- HLF-009 (CR#2013-0007) Updated the requirement ISC- HLF-002 (CR#2013-0010R01) Updated the requirement ISC- HLF-003 (CR#2013-0011R01)
		Section 6.1.11	Updated the requirement ISC- USA-003 and ISC-USA-004 (CR#2013-0009R01)
	15 Feb. 2013	Section 6.1.3	Updated the requirement ISC-UIC-001 (CR#2013-0008R01)
		Section 6.1.7	Updated the requirement ISC-MAN-003 (CR#2013-0018R01) Updated the requirements ISC-MAN-004 and ISC-MAN-005 (CR#2013-0023)
		Section 3.2	Add eight new abbreviations (CR#2013-0020)
		Section 6.1	Updated two requirements ISC-HLF-006 and ISC-HLF-007 (CR#2013-0022R01)
	22 Feb 2013	Section 6.1	Updated the requirement ISC-HLF-001 (CR#2013-0014R02) Updated the requirement ISC-HLF-008 (CR#2013-0035R01)
		Section 6.1.6	Updated the requirement ISC-CVG-003 and added a new requirement ISC-CVG-007 (CR#2013-0015R02) Update parts of the requirements in this section (CR#2013-0026R01)
		Section 6.1.2 Section 6.1.11	Moved the requirement ISC-USA-001 to section 6.1.2 as ISC-MDS-005 and updated it (CR#2013-0016R01, CR#2013-0028R02)
		Section 3.2	Updated the definition 'Continuous Content View' (CR#2013-0017R02) Updated parts of the definitions (CR#2013-0053)
		Section 6.1.7 Section 3.2	Updated the requirements ISC-MAN-001 and ISC-MAN-002, and added one definition (CR#2013-0019R02, CR#2013-0069R01)
		Section 1	Updated the scope (CR#2013-0021R01)
		Section 6.1.8.2	Updated parts of the requirements in this section (CR#2013-0027R01)

Document Identifier	Date	Sections	Description
		Section 6.1.3 Section 3.2	Merged the requirements ISC-UIC-005 and ISC-UIC-006, and added one definition (CR#2013-0030R01) Updated the requirement ISC-UIC-009 (CR#2013-0038R01) Updated the requirement ISC-UIC-010 (CR#2013-0039R01) Updated the requirement ISC-UIC-011 (CR#2013-0040R01) Merged the requirements ISC-UIC-002 and ISC-UIC-003, and added the requirement ISC-UIC-001 (CR#2013-0059R01, CR#2013-0060R02, CR#2013-0062R01)
		Section 6.1.8	Updated the requirement ISC-SEC-004 (CR#2013-0031)
		Section 6.1.9	Updated the requirement ISC-CHG-001 (CR#2013-0033)
		Section 6.1.11 Section 6.1.12	Updated parts of the requirements in section 6.1.11 and ISC-INT-001 (CR#2013-0034R01)
		Section 6.1.1 Section B.3	Updated the requirement ISC-IMM-004 (CR#2013-0036R01) Updated parts of the requirements in this section and updated one use case (CR#2013-0068R01)
		Section 6.1.4	Updated the requirements ISC-SYN-001 and ISC-SYN-002 (CR#2013-0041R01) Updated the requirement ISC-SYN-003 (CR#2013-0042) Updated the requirement ISC-SYN-004 (CR#2013-0043) Updated the requirement ISC-SYN-005 (CR#2013-0044)
		Section 6.1.5	Updated the requirements ISC-COM-001 and ISC-COM-002 (CR#2013-0047, CR#2013-0050R01) Updated the requirement ISC-COM-004 (CR#2013-0049R01) Added a new requirement ISC-COM-005 (CR#2013-0063R02)
		Section 6	Deleted a Editor Note (CR#2013-0051R01)
		Section 2.2 Section 6.1.8.4 Section 6.1.13	Added one informative reference, and added two new requirements ISC-CON-001 and ISC-PRV-001 (CR#2013-0052R01)
		Section 6.1.2	Updated the requirement ISC-MDS-004 (CR#2013-0054R01) Updated the requirement ISC-MDS-002 (CR#2013-0055)
		Section 4	Updated the introduction (CR#2013-0057R01)
		Section 2.2 Section 3.2 Section 3.3 Section 6.1.14	Added two informative references, one definition, and two abbreviations, and added one requirement ISC-IWG-001 (CR#2013-0067R03)
		Section 4.1 Section 6.1 Section 6.1.3 Section 6.1.4 Section 6.1.5	Updated the section 4.1, and updated requirement ISC-SYN-002, and moved ISC-COM-003 and ISC-COM-004 to section 6.1.3 and reordered the labels, and moved HLF-001 and HLF-005 to section 6.1.3, moved ISC-UIC-005 to section 6.1.5 (CR#2013-0070R01)
		28 Feb 2013	all
Candidate Version OMA-RD-ISC-V1_0	02 Apr 2013	n/a	Status changed to Candidate by TP TP Ref # OMA-TP-2013-0098R01- INP_COM_ISC_1_0_RD_for_Candidate_Approval

Appendix B. Use Cases (Informative)

B.1 Multi-Device Support

This use case shows an end user accesses the service on the multi-device environment and the multi-devices of the same user can exchange their Content Viewing Information. In this use case, the end user has two terminals (a TV and a mobile) at the same time, by which the user can access the service. The two terminals can exchange their content viewing and synchronize the Content Viewing Information when content viewing and communication are distributed on different devices.

B.1.1 Actors

Network Operator:

Provides the network which carries the service and provides all the infrastructures for authentication, authorization, accounting and service / content adaptation.

Service Provider:

Provides the service with synchronization function for content viewing and communication between the devices of the same end user in multi-device environment.

Content Provider:

Owner of the content provided as part of the service provided by the service provider.

End User:

Consumes the service with his/her terminals (a TV and a mobile), e.g., viewing content or chatting with other consumers.

B.1.2 Actor Specific issues

End User:

Wants to access the service with any of his/her terminals, and hopes the two terminals can synchronize Content Viewing Information when content viewing and communication being distributed on different devices.

B.1.3 Actor Specific Benefits

End User:

Flexible to access the service with any of his/her terminals.

Service Provider:

Provides nice user experience to improve the service penetrations.

B.1.4 Pre-conditions

The two terminals of the end user can access the service, and support content viewing and communication functions.

B.1.5 Post-conditions

End user is seamlessly accessing content viewing and communication across his multiple devices.

B.1.6 Normal Flow

1. The end user opens his/her two terminals, TV and mobile.

2. The end user discovers an interesting content using the mobile, then selects the content and require the TV to render the content. The TV gets the request, and then renders the content, after that, the TV sends the Content Viewing Information to the mobile at a certain time interval pre-defined by the end user.
3. The end user discovers another interesting content using the TV, and then starts to render the new content, after that, the TV notifies the mobile the changes and sends the new Content Viewing Information to the mobile at the certain time interval.
4. The end user selects a new content using the mobile and requires the TV and the mobile to render the content at the same time. Then, the TV and the mobile synchronously render the content respectively.
5. The end user wants to stop the content viewing progress on the TV and/or on the mobile, who can send the request from the TV or the mobile, after that, the TV and the mobile stop the progress.

B.1.7 Alternative Flow

1. Mobile follows TV

Suppose that the end user now is not at home. If the end user wants to know what content is rendered on his/her TV, he/she can open his/her mobile. The mobile will check the status of the TV, if the TV is open and rendering media content, then the mobile can request to synchronize the Content Viewing Information from the TV. And more, the end user's mobile can render the same media content synchronously with the TV.

2. TV follows mobile

Suppose that the end user is on the road, and rendering a media content using the mobile. When the end user is back to home, he/she can request the TV to render the media content from the current playing time of the mobile, and then, the TV renders the media content from that time, optionally continuing to render on mobile too.

B.1.8 Operational and quality of Experience Requirement

None specified.

B.2 Content Viewing Group

B.2.1 Short Description

This use case shows an end user creates and manages his/her Content Viewing Group, and the participants in the group share their Content Viewing Information.

B.2.2 Actors

Network Operator:

Provides the network which carries the service and provides all the infrastructures for authentication, authorization, accounting and service / content adaptation.

Service Provider:

Provides the service with functionalities for Content Viewing Group.

Content Provider:

Owner of the content provided as part of the service provided by the service provider.

End User:

Four end users, Alice, Claire, Bob, and John.

B.2.3 Actor Specific issues

End User:

Accesses the service and shares the Content Viewing Information in a Content Viewing Group.

B.2.4 Actor Specific Benefits

End User:

Flexible to access the service and share the Content Viewing Information.

Service Provider:

Provides nice user experience to improve the service penetrations.

B.2.5 Pre-conditions

The four end users have subscribed the service.

B.2.6 Post-conditions

The four end users were able to watch and discuss the content together. The content viewing which is shared in the Content Viewing Group can be paused and resumed synchronously between all members in the group. And when ISC User leaves the Content Viewing Group, the content viewing which has been paused before joining the group can be resumed.

B.2.7 Normal Flow

1. Alice opens her terminal, and selects a media content to view. She finds it interesting and wants to watch the content along with her friends. So, she creates a Content Viewing Group including her friends (Bob, Claire, John) she wants to invite.
2. Alice finds her friends Bob and Claire are online, and then she sends an invitation including the Content Viewing Information to Bob and Claire for joining the group.
3. When Bob and Claire receive the invitation, they accept the invitation and joins into the group using their terminals individually. After Bob and Claire join into the group, their terminals synchronize Alice's Content Viewing Information respectively. Alice, Bob and Claire discuss the content online.
4. John, who was offline before, finds the group (e.g., by searching) and knows his friends Bob, Claire and Alice are in the Content Viewing Group. John sends a message to the group to request joining into the group using his terminal.
5. The request is forwarded to Alice's terminal, and then Alice welcomes John's participation.
6. When John joins into the group, his terminal synchronizes Alice's Content Viewing Information, and also John joins the discussion with Alice, Claire and Bob.
7. After some time, Bob needs to leave the group. Bob sends a message to the group and leaves the group. The message is forwarded to the Content Viewing Group participants Alice, Claire and John.
8. Alice has to leave the group for some reasons, so she sends a message informing the group.
9. The service sends Claire and John, a message to notify that the group will be closed.
10. Claire and John receive the notification, and they continue to watch the content individually.

B.2.8 Alternative Flow I

Alice identifies who she would like to be in the Content Viewing Group when she is creating the group and sends the invitation to all of them (Bob, Claire, and John). Bob and Claire will respond and accept the invitation and be sync with Alice's viewing content but John will join later when he is aware of the invitation.

B.2.9 Alternative Flow II

1. Alice opens her terminal, and selects a media content to view. She finds it interesting and wants to watch the content along with her friends. So, she creates a Content Viewing Group including her friends (Bob and Claire) she wants to invite.
2. Alice finds her friends Bob and Claire are online, and then she sends an invitation including the Content Viewing Information to Bob and Claire for joining the group.
3. When Bob receives the invitation, he accepts the invitation and joins into the group using his terminal individually. After Bob joins into the group, his terminal synchronizes Alice's Content Viewing Information respectively.
4. When Claire receives the invitation, she is watching another content viewing, when she accepts the invitation, the current content viewing which is watched is paused and Claire joins into the group using her terminal individually. After Claire joins into the group, her terminal synchronizes Alice's Content Viewing Information respectively.
5. After some time, Alice has a phone call come in, so she pauses the content viewing, Bob and Claire's content viewings are also paused synchronously.
6. After the phone call, Alice resumes the content viewing, Bob and Claire's content viewings are also resumed synchronously.
7. After some time Claire needs to leave the group, Claire sends a message to the group and leaves the group, after that the previous content viewing which has been paused is popped up and Claire resumes watching it.

B.2.10 Operational and quality of Experience Requirement

None specified.

B.3 Immersive Environment

This use case shows how end users access the service in an immersive environment, which distributes Content Views and/or Continuous Content Views based on user context awareness. In this use case, the end user Alice is watching live television programs at home, and she can request to watch the live event from the scene according to the specific field of view and viewing distance she like. Also in this use case, the end user Bob is participating in a multilateral meeting in the office, and he can request to observe other participants' screen and speak according to the spatial configuration of their participating terminals.

B.3.1 Actors

Service Provider:

Provides the service with functionalities for the immersive content viewing environment.

Content Provider:

Owner of the content provided as part of the service provided by the service provider.

End User:

Alice and Bob who are the service's subscribers.

B.3.2 Actor Specific issues

End User:

Accesses the service and needs for more realistic (immersive) content viewing experience.

B.3.3 Actor Specific Benefits

End User:

Flexible to access the service with immersive content viewing experience ("being-there" and "being-with").

Service Provider:

Provides nice user experience to improve the service penetrations.

B.3.4 Pre-conditions

The two end users can access the service and their terminals support content viewing in immersive environment.

B.3.5 Post-conditions

The two end users access the service with immersive content viewing experience (“being-there” and “being-with”).

B.3.6 Normal Flow

1. Alice turns on the TV to watch a live program at home.
2. The live program is produced with multiple video sources by the Content Provider and one or some of them will be delivered by the Service Provider according to ISC Users’ needs. At first, Alice watches the live program in the default Content View, e.g. with preset field of view and viewing distance.
3. After a while, Alice wants to change her viewing perspective (e.g. look the left side) to see more details, so she requests the TV to change the Content View to the left direction. Now Alice can watch more live event from the scene as if she came to the show physically (“being-there”).
4. Alice wants to change her viewing position (e.g. step closer) to observe one specific region, so she requests the TV to change the Content View to the region of interest. Now Alice can watch more clearly from the scene as if she came to the show physically (“being-there”).

B.3.7 Alternative Flow

1. Bob turns on the terminal to participate in a Content Viewing Group.
2. The Content Viewing Group is attended by users from different places. Bob wants to distinguish different participants in a natural way, so Bob requires his terminal to distribute and render other participants’ screen and speech according to the Spatial Configuration (e.g. left participants’ view and speech distributed to the left-positioned device) in a spatially appropriate manner even though each participant has a different number of devices (e.g. microphone, camera, speaker). Now it can be more natural for Bob to communicate with all these participants (“being-with”).
3. After a while, the other participants join the Content Viewing Group, whose participation changes the relative spatial relationship between Content Viewing Group participants. Bob’s terminal can automatically distribute and render all other participants’ screen and speech according to the change of its Spatial Configuration.

B.3.8 Operational and quality of Experience Requirement

None specified.

B.4 Synchronization

B.4.1 Short Description

This use case shows that two users can watch the same content at the same time and they can synchronize even the same views when available.

B.4.2 Actors

Network Operator:

Provides the network which carries the service and provides all the infrastructures for authentication, authorization, accounting and service / content adaptation.

Service Provider:

Provides the contents and the contents with multiple views.

Content Provider:

Owner of the content provided as part of the service provided by the service provider.

End User:

Two end users - Alice and Bob.

B.4.3 Actor Specific issues

End User:

Accesses the service and synchronizes the contents with views.

B.4.4 Actor Specific Benefits

End User:

Flexible to access the service and synchronizes the content viewing with another user.

Service Provider:

Provides nice user experience to improve the service penetrations.

B.4.5 Pre-conditions

Alice and Bob have subscribed the service.

B.4.6 Post-conditions

The two end users are in same context while watching content and discuss the content together. The two end users can start and stop synchronizing the content views.

B.4.7 Normal Flow

1. Alice opens her terminal, and selects a program to watch.
2. Bob is also available and watching another program.
3. Alice and Bob establish communication session between each other.
4. Alice knows that Bob is watching different programs and wants to watch the same program and view as Bob is watching.
5. Alice requests to start synchronize with the Content View of Bob.
6. Bob has allowed Alice to synchronize his Content View.
7. Alice gets to watch the same Content View as Bob is watching at the same elapsed time.
8. Bob changes to another Content View of the same program.
9. Alice gets notified that Bob has changed to another Content View.
10. Alice's Content View also changes to the same Content View as what Bob has switched to.
11. Alice wants to watch another program and requests to stop synchronizing with Bob's Content View.
12. Both Alice and Bob can continue to remain in communication session while watching different programs.

B.4.8 Operational and quality of Experience Requirement

None specified.