



LAWMO Architecture

Candidate Version 1.0 – 27 Jan 2009

Open Mobile Alliance
OMA-AD-LAWMO-V1_0-20090127-C

Use of this document is subject to all of the terms and conditions of the Use Agreement located at <http://www.openmobilealliance.org/UseAgreement.html>.

Unless this document is clearly designated as an approved specification, this document is a work in process, is not an approved Open Mobile Alliance™ specification, and is subject to revision or removal without notice.

You may use this document or any part of the document for internal or educational purposes only, provided you do not modify, edit or take out of context the information in this document in any manner. Information contained in this document may be used, at your sole risk, for any purposes. You may not use this document in any other manner without the prior written permission of the Open Mobile Alliance. The Open Mobile Alliance authorizes you to copy this document, provided that you retain all copyright and other proprietary notices contained in the original materials on any copies of the materials and that you comply strictly with these terms. This copyright permission does not constitute an endorsement of the products or services. The Open Mobile Alliance assumes no responsibility for errors or omissions in this document.

Each Open Mobile Alliance member has agreed to use reasonable endeavors to inform the Open Mobile Alliance in a timely manner of Essential IPR as it becomes aware that the Essential IPR is related to the prepared or published specification. However, the members do not have an obligation to conduct IPR searches. The declared Essential IPR is publicly available to members and non-members of the Open Mobile Alliance and may be found on the “OMA IPR Declarations” list at <http://www.openmobilealliance.org/ipr.html>. The Open Mobile Alliance has not conducted an independent IPR review of this document and the information contained herein, and makes no representations or warranties regarding third party IPR, including without limitation patents, copyrights or trade secret rights. This document may contain inventions for which you must obtain licenses from third parties before making, using or selling the inventions. Defined terms above are set forth in the schedule to the Open Mobile Alliance Application Form.

NO REPRESENTATIONS OR WARRANTIES (WHETHER EXPRESS OR IMPLIED) ARE MADE BY THE OPEN MOBILE ALLIANCE OR ANY OPEN MOBILE ALLIANCE MEMBER OR ITS AFFILIATES REGARDING ANY OF THE IPR'S REPRESENTED ON THE “OMA IPR DECLARATIONS” LIST, INCLUDING, BUT NOT LIMITED TO THE ACCURACY, COMPLETENESS, VALIDITY OR RELEVANCE OF THE INFORMATION OR WHETHER OR NOT SUCH RIGHTS ARE ESSENTIAL OR NON-ESSENTIAL.

THE OPEN MOBILE ALLIANCE IS NOT LIABLE FOR AND HEREBY DISCLAIMS ANY DIRECT, INDIRECT, PUNITIVE, SPECIAL, INCIDENTAL, CONSEQUENTIAL, OR EXEMPLARY DAMAGES ARISING OUT OF OR IN CONNECTION WITH THE USE OF DOCUMENTS AND THE INFORMATION CONTAINED IN THE DOCUMENTS.

© 2009 Open Mobile Alliance Ltd. All Rights Reserved.

Used with the permission of the Open Mobile Alliance Ltd. under the terms set forth above.

Contents

- 1. SCOPE (INFORMATIVE)4
- 2. REFERENCES5
 - 2.1 NORMATIVE REFERENCES.....5
 - 2.2 INFORMATIVE REFERENCES.....5
- 3. TERMINOLOGY AND CONVENTIONS6
 - 3.1 CONVENTIONS.....6
 - 3.2 DEFINITIONS.....6
 - 3.3 ABBREVIATIONS.....6
- 4. INTRODUCTION (INFORMATIVE).....7
 - 4.1 PLANNED PHASES.....7
 - 4.2 SECURITY CONSIDERATIONS.....7
- 5. ARCHITECTURAL MODEL.....8
 - 5.1 DEPENDENCIES.....8
 - 5.2 ARCHITECTURAL DIAGRAM8
 - 5.3 FUNCTIONAL COMPONENTS SPECIFIED BY THIS ENABLER.....8
 - 5.3.1 LAWMO Server.....8
 - 5.3.2 LAWMO Client9
 - 5.4 OTHER ENABLERS AND COMPONENTS.....9
 - 5.4.1 DM Server.....9
 - 5.4.2 DM Client9
 - 5.4.3 External Management Infrastructure.....9
 - 5.5 INTERFACES SPECIFIED BY THIS ENABLER.....9
 - 5.5.1 LAWMO-1: LAWMO Client <- LAWMO Server9
 - 5.5.2 LAWMO-2: LAWMO Server <- LAWMO Client9
 - 5.6 OTHER INTERFACES.....10
 - 5.6.1 DM-1: DM Server <-> DM Client.....10
 - 5.7 FLOWS10
 - 5.7.1 LAWMO Server Interactions with LAWMO Client on the Device for LAWMO Operations without User Confirmation/Notification10
 - 5.7.2 LAWMO Server Interactions with LAWMO Client on the Device for LAWMO Operations with User Confirmation.....11
- APPENDIX A. CHANGE HISTORY (INFORMATIVE).....12
 - A.1 APPROVED VERSION HISTORY12
 - A.2 DRAFT/CANDIDATE VERSION 1.0 HISTORY12

Figures

- Figure 1: LAWMO Architecture Diagram.....8

1. Scope

(Informative)

The scope of this document is to define the architecture for the LAWMO Enabler. The LAWMO Enabler is based on the OMA DM Enabler [DM-ENABLER] and makes use of the functionalities provided by the OMA DM protocol [DMPRO] to define Lock and Wipe functionalities to protect user and enterprise-related data in the device.

This document fulfils the functional capabilities needed to support this enabler as described in the LAWMO Requirements document [LAWMO-RD].

2. References

2.1 Normative References

- [DM-ENABLER] “OMA Device Management Enabler Release Package”, Version 1.2.1, Open Mobile Alliance, OMA-ERP-DM-V1_2_1, URL:<http://www.openmobilealliance.org/>
- [DMPRO] “OMA Device Management Protocol”, Version 1.2, Open Mobile Alliance, OMA-TS-DM_Protocol-V1_2, URL:<http://www.openmobilealliance.org/>
- [LAWMO -RD] “LAWMO Requirements”, Version 1.0, Open Mobile Alliance™, OMA-RD- LAWMO -V1_0, URL:<http://www.openmobilealliance.org/>
- [OSE] “OMA Service Environment”, Open Mobile Alliance™, URL:<http://www.openmobilealliance.org/>
- [RFC2119] “Key words for use in RFCs to Indicate Requirement Levels”, S. Bradner, March 1997, URL:<http://www.ietf.org/rfc/rfc2119.txt>

2.2 Informative References

- [OMADICT] “Dictionary for OMA Specifications”, Version 2.6, Open Mobile Alliance™, OMA-ORG-Dictionary-V2_6, URL:<http://www.openmobilealliance.org/>

3. Terminology and Conventions

3.1 Conventions

The key words “MUST”, “MUST NOT”, “REQUIRED”, “SHALL”, “SHALL NOT”, “SHOULD”, “SHOULD NOT”, “RECOMMENDED”, “MAY”, and “OPTIONAL” in this document are to be interpreted as described in [RFC2119].

All sections and appendixes, except “Scope” and “Introduction”, are normative, unless they are explicitly indicated to be informative.

3.2 Definitions

Device	see [OMADICT]
Device Management	Management of the Device configuration and other managed objects of Devices from the point of view of the various Management Authorities. Device Management includes: <ul style="list-style-type: none">- Setting initial configuration information in Devices- Subsequent updates of persistent information in Devices- Retrieval of management information from Devices Processing events and alarms generated by Devices
LAWMO Alert	LAWMO specific alerts which convey the result of LAWMO Operations via DM Generic Alert mechanism [DMPRO].

3.3 Abbreviations

DM	Device Management
DMS	Device Management Server
LAWMO	Lock And Wipe Management Object
MO	Management Object
OMA	Open Mobile Alliance

4. Introduction (Informative)

The mobile device is becoming a pocketable private information database. If the device is lost or stolen, there is a risk of data being compromised either maliciously or by accident. This Enabler will address interoperable remote operations such as Lock/Unlock Device, Wipe Device's Data and Factory Reset. This Enabler will provide Management Authorities an effective way to protect user and enterprise-related data.

The objective of this document is to describe the architecture for Lock and Wipe Management.

4.1 Planned Phases

The LAWMO 1.0 Enabler release is expected to meet all the requirements defined in [LAWMO-RD] and no additional phases are planned at this stage.

4.2 Security Considerations

The LAWMO Enabler depends on the security mechanisms and protections provided by the OMA DM enabler. It should normally not impact the security framework already defined in the OMA DM Enabler.

5. Architectural Model

5.1 Dependencies

The LAWMO 1.0 architecture diagram indicates dependencies on the OMA DM Enabler v1.2.

5.2 Architectural Diagram

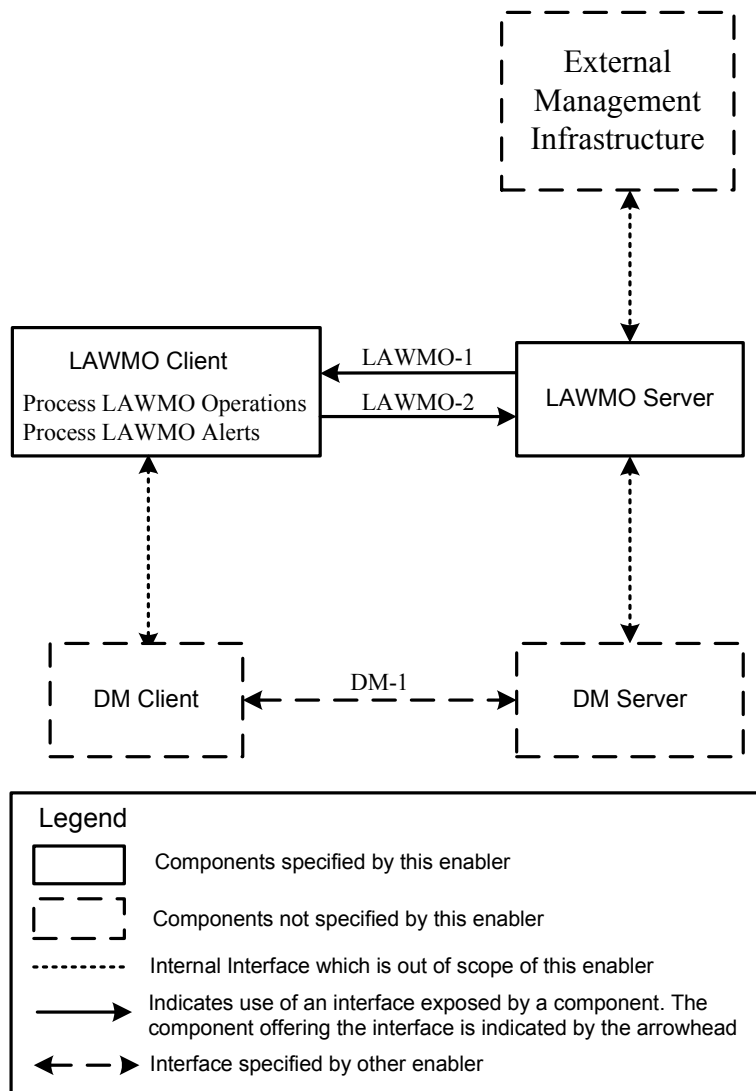

Figure 1: LAWMO Architecture Diagram

5.3 Functional Components Specified by this Enabler

5.3.1 LAWMO Server

The LAWMO Server is a logical entity which is dedicated to issue LAWMO Operations to the device and/or consume the LAWMO Alerts from the device.

5.3.2 LAWMO Client

The LAWMO Client is a logical entity which is responsible for conducting the management activities to protect device's data according to the LAWMO Operations received. LAWMO Client is also responsible for sending LAWMO Alerts to the LAWMO Server.

5.4 Other Enablers and Components

5.4.1 DM Server

The DM Server is an entity which conveys the appropriate device management operations to the device over various bearer technologies, represented by the DM-1 interface. It can also receive specific alerts from the DM Client for success or failure of management activities. LAWMO does not define or specify the DM Server.

5.4.2 DM Client

The DM Client is an entity which makes it possible for the DM Server to manage the device using the DM protocol defined in [DMPRO]. The DM Client can access LAWMO provided by the LAWMO Enabler such that the DM Server can manipulate it. The DM Client employs the DM Generic Alert mechanism [DMPRO] to send the result of the management activities to DM Server. LAWMO does not define or specify the DM Client.

5.4.3 External Management Infrastructure

The Device Management System comprises a set of external management components over and above the DM Server that participate in the overall process of managing devices. The external management infrastructure is used but not defined or specified within the scope of the LAWMO.

5.5 Interfaces Specified by this Enabler

5.5.1 LAWMO-1: LAWMO Client <- LAWMO Server

The LAWMO-1 interface is exposed by LAWMO Client which allows the LAWMO Server to perform LAWMO Operations. Through this interface the LAWMO Server can perform LAWMO Operations on the device. The LAWMO Operations will be conveyed by DM messages through the underlying DM-1 interface.

5.5.2 LAWMO-2: LAWMO Server <- LAWMO Client

The LAWMO-2 interface is exposed by LAWMO Server which allows the LAWMO Client to send LAWMO Alerts. Through this interface the LAWMO Server can receive results of LAWMO Operations on the device. The LAWMO Alerts will be conveyed by DM messages through the underlying DM-1 interface.

5.6 Other Interfaces

5.6.1 DM-1: DM Server <-> DM Client

The DM-1 interface is defined in the DM Enabler[DMPRO]. It provides an interface over which the DM Server can send device management operations to the DM Client and the DM Client can return status and alerts to DM Server. This interface is used but not defined or specified within the scope of the LAWMO Enabler.

5.7 Flows

5.7.1 LAWMO Server Interactions with LAWMO Client on the Device for LAWMO Operations without User Confirmation/Notification

This flow describes the interaction between the LAWMO Client on the device and the LAWMO Server wherein the LAWMO Server invokes LAWMO functionality on the device.

This condition would typically apply in the following use case:

- **Partial Lock/Unlock Operation:** An End User (Jack) finds he has left his mobile device in a taxi and wants to Partially Lock his device. Jack's device is now protected from fraudulent use and his personal information cannot be perused. Jack can call his device hoping the person in possession of it will return it to him. The taxi driver answers and Jack arranges to pick up his device. After picking up his device he calls Customer Care to unlock his device and return it to full functionality. These operations will be performed without user confirmation.
- **Full Lock/Wipe Operation:** An End User realizes his device has been stolen and requests his device to be fully locked to protect his device from fraudulent use and his personal information cannot be perused. In addition he may request to wipe all his personal and enterprise-related data. These operations will be performed without user confirmation and without user notification.

5.7.1.1 Normal Flow

1. The LAWMO Server sends notifications to DM Server to perform LAWMO Operation on the device without User Confirmation/Notification.
2. The DM Server notifies the DM Client to initiate the device management session.
3. The DM Server sends the DM command(s) to DM Client on the device to perform a LAWMO Operation.
4. The DM Client executes the DM command(s) sent from DM Server.
5. The LAWMO Client performs the requested LAWMO Operation.
6. The DM Client reports the results of the requested LAWMO Operation excluding the Factory Reset operation (which could only return status indicating the DM command has been received rather than results) to the DM Server.
7. The DM Server relays the results of the requested LAWMO Operation excluding the Factory Reset operation (which could only return status indicating the DM command has been received rather than results) to the LAWMO Server.

5.7.2 LAWMO Server Interactions with LAWMO Client on the Device for LAWMO Operations with User Confirmation

This flow describes the interaction between the LAWMO Client on the device and the LAWMO Server wherein the LAWMO Server invokes a LAWMO Operation which requires User confirmation prior to execution.

This condition would typically apply in the following use case:

- Wipe Operation: An End User wants to upgrade his device and sell the old one on the internet. He wishes to permanently wipe all his personal and/or enterprise-related data from device with user confirmation.
- Factory Reset Operation: Non-end users, such as mobile network operators, device manufacturers, or resellers of second-hand devices, require the capability to reset devices to the factory clean state automatically and easily and allow user to confirm this operation before execution.

5.7.2.1 Normal Flow

1. The User requests, via External Management Infrastructure, a LAWMO Operation be performed on the device
2. LAWMO Server sends notifications to DM Server to perform LAWMO Operation on the device with indication that User confirmation is required.
3. The DM Server notifies the DM Client to initiate the device management session.
4. The DM Server sends the DM command(s) to DM Client on the device to perform a LAWMO Operation, with User confirmation required.
5. The DM Client presents the User with the opportunity to confirm execution of the LAWMO Operation.
6. Upon positive confirmation, the DM Client executes the DM command(s) sent from DM Server.
7. The LAWMO Client performs the requested LAWMO Operation.
8. The DM Client reports the results of the LAWMO Operation excluding the Factory Reset operation (which could only return status indicating the command has been received rather than results) to the DM Server.
9. The DM Server relays the results of the requested LAWMO Operation excluding the Factory Reset operation (which could only return status indicating the DM command has been received rather than results) to the LAWMO Server.

Appendix A. Change History (Informative)

A.1 Approved Version History

Reference	Date	Description
n/a	n/a	No prior version

A.2 Draft/Candidate Version 1.0 History

Document Identifier	Date	Sections	Description
Draft Versions OMA-AD-LAWMO-V1_0	6 Sep 2007	All	First Draft Baseline
	20 Sep 2007	5.1,5.2,5.3,5.4,5.5,5.6	First Design
	30 Nov 2007	5.7	Incorporates agreed document: OMA-DM-LAWMO-2007-0017R03-CR_LAWMO_AD_FLOW.doc
	01 Jun 2008	5.3.1,5.6.1,5.7.1	Incorporates agreed document: OMA-DM-LAWMO-2008-0001R01-CR_AD_Bug Fixes.doc
	20 Sep 2008	2.1,1.2.2.3.1,5.2,5.7.1.1,5.7.2.1	Incorporates agreed document: OMA-DM-LAWMO-2008-0016-CR_ADRR_A001_A007 OMA-DM-LAWMO-2008-0022-CR_ADRR_A008
Draft Versions OMA-AD-LAWMO-V1_0	27 Jan 2009	n/a	Status changed to Candidate by TP TP ref# OMA-TP-2009-0010- INP_LAWMO_V1_0_ERP_for_Candidate_Approval