



Presence Access Layer Architecture

Candidate Version 1.0 – 17 Aug 2010

Open Mobile Alliance
OMA-AD-PAL-V1_0-20100817-C

Use of this document is subject to all of the terms and conditions of the Use Agreement located at <http://www.openmobilealliance.org/UseAgreement.html>.

Unless this document is clearly designated as an approved specification, this document is a work in process, is not an approved Open Mobile Alliance™ specification, and is subject to revision or removal without notice.

You may use this document or any part of the document for internal or educational purposes only, provided you do not modify, edit or take out of context the information in this document in any manner. Information contained in this document may be used, at your sole risk, for any purposes. You may not use this document in any other manner without the prior written permission of the Open Mobile Alliance. The Open Mobile Alliance authorizes you to copy this document, provided that you retain all copyright and other proprietary notices contained in the original materials on any copies of the materials and that you comply strictly with these terms. This copyright permission does not constitute an endorsement of the products or services. The Open Mobile Alliance assumes no responsibility for errors or omissions in this document.

Each Open Mobile Alliance member has agreed to use reasonable endeavors to inform the Open Mobile Alliance in a timely manner of Essential IPR as it becomes aware that the Essential IPR is related to the prepared or published specification. However, the members do not have an obligation to conduct IPR searches. The declared Essential IPR is publicly available to members and non-members of the Open Mobile Alliance and may be found on the “OMA IPR Declarations” list at <http://www.openmobilealliance.org/ipr.html>. The Open Mobile Alliance has not conducted an independent IPR review of this document and the information contained herein, and makes no representations or warranties regarding third party IPR, including without limitation patents, copyrights or trade secret rights. This document may contain inventions for which you must obtain licenses from third parties before making, using or selling the inventions. Defined terms above are set forth in the schedule to the Open Mobile Alliance Application Form.

NO REPRESENTATIONS OR WARRANTIES (WHETHER EXPRESS OR IMPLIED) ARE MADE BY THE OPEN MOBILE ALLIANCE OR ANY OPEN MOBILE ALLIANCE MEMBER OR ITS AFFILIATES REGARDING ANY OF THE IPR'S REPRESENTED ON THE “OMA IPR DECLARATIONS” LIST, INCLUDING, BUT NOT LIMITED TO THE ACCURACY, COMPLETENESS, VALIDITY OR RELEVANCE OF THE INFORMATION OR WHETHER OR NOT SUCH RIGHTS ARE ESSENTIAL OR NON-ESSENTIAL.

THE OPEN MOBILE ALLIANCE IS NOT LIABLE FOR AND HEREBY DISCLAIMS ANY DIRECT, INDIRECT, PUNITIVE, SPECIAL, INCIDENTAL, CONSEQUENTIAL, OR EXEMPLARY DAMAGES ARISING OUT OF OR IN CONNECTION WITH THE USE OF DOCUMENTS AND THE INFORMATION CONTAINED IN THE DOCUMENTS.

© 2010 Open Mobile Alliance Ltd. All Rights Reserved.

Used with the permission of the Open Mobile Alliance Ltd. under the terms set forth above.

Contents

1.	SCOPE (INFORMATIVE)	4
2.	REFERENCES	5
2.1	NORMATIVE REFERENCES	5
2.2	INFORMATIVE REFERENCES	5
3.	TERMINOLOGY AND CONVENTIONS	6
3.1	CONVENTIONS	6
3.2	DEFINITIONS	6
3.3	ABBREVIATIONS	7
4.	INTRODUCTION (INFORMATIVE)	8
4.1	VERSION 1.0	8
5.	ARCHITECTURAL MODEL	9
5.1	DEPENDENCIES	9
5.1.1	OMA Presence SIMPLE Enabler	9
5.1.2	OMA XML Document Management Enabler	9
5.1.3	OMA Push Enabler	9
5.2	ARCHITECTURAL DIAGRAM	9
5.3	PAL FUNCTIONAL COMPONENTS AND INTERFACES	10
5.3.1	PAL Client	11
5.3.2	PAL Server	11
5.3.3	PAL XDMS	11
5.3.4	PAL-1i Interface	12
5.3.5	PAL Enabler Reference Points	12
5.3.6	PAL deployment - 3GPP IMS network	12
5.4	SECURITY CONSIDERATIONS	13
APPENDIX A.	CHANGE HISTORY (INFORMATIVE)	14
A.1	APPROVED VERSION HISTORY	14
A.2	DRAFT/CANDIDATE VERSION 1.0 HISTORY	14
APPENDIX B.	FLOWS (INFORMATIVE)	16
B.1	PAL PRESENCE CONTEXT ESTABLISHMENT	16
B.2	REQUESTING SPECIFIC PRESENCE INFORMATION	17
B.3	PRESENCE TRIGGER PREDEFINED ACTION	18

Figures

Figure 1:	PAL Architecture Diagram	10
Figure 2:	PAL Deployment – 3GPP IMS Network	13
Figure 3:	Establishing Presence Context based on a Presence Aware Service	16
Figure 4:	Requesting a Presence Aspect relative to a Presence Context	17
Figure 5:	Receiving a Predefined Action corresponding with a Presence Trigger	18

1. Scope

(Informative)

This document provides the architecture for the Presence Access Layer (PAL) Enabler of OMA.

The PAL Enabler provides a series of Interfaces for accessing and making use of Presence Information on behalf of one or more interested individuals (i.e. Logical Observers). Access to Presence Information on behalf of a Logical Observer is based on a contextually aware perspective or view. The presence view/perspective is resolved by the PAL Enabler relative to a Presence Aware Service or Class of Service, and potentially other factors including a requestor identity.

The scope of the PAL architecture document is intended to facilitate the development of specifications for establishing a presence view/perspective, and Interfaces relevant to the access and use of Presence Information. Further, the architecture supports possible reuse by other enablers in order to provide simple and efficient access to Presence Information.

2. References

2.1 Normative References

3GPP

[3GPP-TS_23.002] 3GPP TS 23.002 “Network architecture”
URL: http://www.3gpp.org/ftp/Specs/archive/23_series/23.002/

IETF

[RFC2119] “Key words for use in RFCs to Indicate Requirement Levels”, S. Bradner, March 1997,
URL: <http://www.ietf.org/rfc/rfc2119.txt>

OMA

[OSE] “OMA Service Environment”, Open Mobile Alliance™,
URL: <http://www.openmobilealliance.org/>

[PAL_RD] “Presence Access Layer Requirements”, Open Mobile Alliance™, OMA-RD-PAL-V1_0,
URL: <http://www.openmobilealliance.org/>

[PRS_RD] “Presence SIMPLE Requirements”, Version 2.0, Open Mobile Alliance™, OMA-RD-Presence_SIMPLE-V2_0,
URL: <http://www.openmobilealliance.org/>

[PUSH_AD] “Push Architecture”, Version 2.2, Open Mobile Alliance™, OMA-AD-Push-V2_2,
URL: <http://www.openmobilealliance.org/>

[PUSH_CAI] “Push Client – Application Interface”, Version 1.0, Open Mobile Alliance™, OMA-TS-PushCAI-V1_0,
URL: <http://www.openmobilealliance.org/>

[PUSH_SIP] “Push using SIP”, Version 1.0, Open Mobile Alliance™, OMA-TS-SIP_Push-V1_0,
URL: <http://www.openmobilealliance.org/>

[XDM_AD] “XML Document Management Architecture”, Version 2.0, Open Mobile Alliance™, OMA-AD-XDM-V2_0,
URL: <http://www.openmobilealliance.org/>

2.2 Informative References

IETF

[RFC4825] “The Extensible Markup Language (XML) Configuration Access protocol (XCAP)”, J. Rosenberg, May 2007,
URL: <http://www.ietf.org/rfc/rfc4825.txt>

[RFC4825] “The Extensible Markup Language (XML) Configuration Access protocol (XCAP)”, J. Rosenberg, May 2007,
URL: <http://www.ietf.org/rfc/rfc4825.txt>

OMA

[OMADICT] “Dictionary for OMA Specifications”, Version 2.7, Open Mobile Alliance™, OMA-ORG-Dictionary-V2_7,
URL: <http://www.openmobilealliance.org/>

[PRS_AD] “Presence SIMPLE Architecture”, Version 2.0, Open Mobile Alliance™, OMA-AD-Presence_SIMPLE-V2_0,
URL: <http://www.openmobilealliance.org/>

[SEC_CF_AD] “Security Common Functions Architecture”, Version 1.1, Open Mobile Alliance™, OMA-AD-SEC_CF-V1_1,
URL: <http://www.openmobilealliance.org/>

[XDM_RD] “XML Document Management Requirements”, Version 2.0, Open Mobile Alliance™, OMA-RD-XDM-V2_0,
URL: <http://www.openmobilealliance.org/>

3. Terminology and Conventions

3.1 Conventions

The key words “MUST”, “MUST NOT”, “REQUIRED”, “SHALL”, “SHALL NOT”, “SHOULD”, “SHOULD NOT”, “RECOMMENDED”, “MAY”, and “OPTIONAL” in this document are to be interpreted as described in [Error! Reference source not found.].

All sections and appendixes, except “Scope” and “Introduction”, are normative, unless they are explicitly indicated to be informative.

3.2 Definitions

Class of Service	A mechanism for identifying a collection or grouping of services, priorities, and/or privileges, which is shared amongst one or more Users.
Component	Use definition from [OMADICT].
Core Network	Use definition from [3GPP-TS_23.002].
Enabler	Use definition from [OMADICT].
Functional Component	Use definition from [OMADICT].
Home Subscription Agent	An entity as described in [PRS_AD] section “ <i>Home Subscription Agent</i> ”.
Interfaces	Use definition from [OMADICT].
Logical Observer	Use definition from [OMADICT].
Notification	Use definition from [PRS_RD].
PAL Administrator	Use definition from [PAL_RD].
PAL Client	Use definition from [PAL_RD].
PAL Initialization	A PAL Service request used to establish a Presence Context.
PAL Presence Parameters	Use definition from [PAL_RD].
PAL Profile	Use definition from [PAL_RD].
PAL Rules	Use definition from [PAL_RD].
PAL Service	Use definition from [PAL_RD].
PAL Subscription	Use definition from [PAL_RD].
Presence Aspect	Use definition from [PAL_RD].
Presence Aware Service	Use definition from [PAL_RD].
Presence Context	Use definition from [PAL_RD].
Presence Information	Use definition from [PRS_RD].
Presence Information Element	Use definition from [PRS_RD].
Presence Service	Use definition from [PRS_RD].
Presence Trigger	Use definition from [PAL_RD].
Presentity	Use definition from [PRS_RD].
Push Access Protocol	Use definition from [PUSH_AD].
Push Client	Use definition of “Client” from [PUSH_AD].
Push Initiator	Use definition from [PUSH_AD].

Push OTA Protocol	Use definition from [PUSH_AD].
Push Proxy Gateway	Use definition from [PUSH_AD].
Reference Point	Use definition from [OMADICT].
Resource List Server	Use definition from [PRS_AD].
Service Provider	Use definition from [OMADICT].
Service XUI	An XUI as described in [RFC4825] which is valid as a URI, and uniquely identifies a Presence Aware Service or Class of Service.
User	Use definition from [OMADICT].
Watcher	Use definition from [PRS_RD].
Watcher Information Subscriber	Use definition from [PRS_RD].
XDM Agent	An XDM entity as described in [XDM_AD], section “ <i>XDM Functional Entities, XDM Agent</i> ”.

3.3 Abbreviations

3GPP	3rd Generation Partnership Project
AD	Architecture Document
AS	Application Server
CAI	Client Application Interface
CN	Core Network
HSA	Home Subscription Agent
HTTP	HyperText Transfer Protocol
IM	Instant Messaging
IMS	IP Multimedia Subsystem
IP	Internet Protocol
NGSI	Next Generation Service Interfaces
OMA	Open Mobile Alliance
OTA	Over The Air
OTA-SIP	(Push) OTA over SIP
PAL	Presence Access Layer
PAP	Push Access Protocol
PDE	OMA Presence SIMPLE Data Extensions
PPG	Push Proxy Gateway
PRS	Presence SIMPLE
PS	Presence Server
RD	Requirements Document
SIMPLE	SIP for Instant Messaging and Presence Leveraging Extensions
SIP	Session Initiation Protocol
URI	Uniform Resource Identifier
XDM	XML Document Management
XDMC	XML Document Management Client
XDMS	XML Document Management Server

XML eXtensible Markup Language

4. Introduction

(Informative)

Presence Aware Services provide service environments with the opportunity to expose enhanced and highly personalised services on behalf of their subscribers. The specification of the Presence Access Layer (PAL) is driven by the requirement to reduce the complexity associated with the access and use of Presence Information on behalf of Presence Aware Services or Class of Services. Further, by specifying common rules for consolidating and presenting Presence Information for Logical Observers, PAL reduces complexity, and provides efficient, consistent presence indications.

This architecture document describes the Functional Components, and Interfaces of the OMA Presence Access Layer (PAL) Enabler. The PAL architecture re-uses OMA Presence SIMPLE [PRS_AD], OMA XML Document Management [XDM_AD], and OMA Push [PUSH_AD] in order to fulfill the requirements defined in the [PAL_RD].

The purpose of the PAL architecture is to provide a common callable interface for Presence Aware Services or Class of Services, to retrieve or be notified of corresponding Presence Information (e.g. PoC Enabler, IM Enabler or NGSI Enabler can retrieve the Presence Information via the PAL Enabler). Presence information is provided by the PAL Enabler through abstractions known as Presence Aspects and/or Presence Triggers. Additionally, the PAL architecture provides a mechanism through which a PAL Service resolves and establishes Presence Context on behalf of a PAL Client. Collectively, these mechanisms provide Presence Aware Services or Class of Services, with a simpler and efficient means with which to incorporate presence awareness, as well as to make adoption by mobile clients quick and easy. Further, PAL Clients achieve minimal coupling to the underlying structure and format of Presence Information Elements, particularly as those elements evolve and change.

4.1 Version 1.0

The PAL Enabler provides the following functions:

- Accepts and authorizes PAL Service requests;
- Resolves Presence Context on behalf of PAL Clients based on a Presence Aware Service or Class of Service;
- Interacts with other Enablers to retrieve and consolidate required information (e.g. Presence SIMPLE, XML Document Management);
- Maintains and upholds the privacy and security of information requested and mediated by the PAL Service;
- Provides appropriate PAL Service responses in the form of Presence Aspects and/or Presence Triggers; and
- Manages and provisions the PAL Service on behalf of Service Providers.

5. Architectural Model

The PAL Architecture Document conforms to [OSE].

5.1 Dependencies

The PAL Enabler has the following dependencies:

- OMA Presence SIMPLE Enabler;
- OMA XML Document Management Enabler; and
- OMA Push Enabler.

5.1.1 OMA Presence SIMPLE Enabler

The PAL Enabler makes use of the following Interfaces from OMA SIMPLE Presence:

- PRS-3i Interface is exposed by the Presence Server and SHALL be used by a PAL Server as detailed in [PRS_AD] “*Description of the Interfaces, PRS-3i Interface*”; and
- PRS-4i Interface is exposed by the Resource List Server and SHALL be used by a PAL Server as detailed in [PRS_AD] “*Description of the Interfaces, PRS-4i Interface*”.

5.1.2 OMA XML Document Management Enabler

The PAL Enabler makes use of the following Interfaces from OMA XML Document Management:

- XDM-4i Interface is exposed by the PAL XDMS and SHALL be used by a PAL Server as described in [XDM_AD] “*Description of Interfaces, XDM Interfaces*”; and
- XDM-6i Interface is exposed by the PAL XDMS and SHALL be used by a PAL Server as described in [XDM_AD] “*Description of Interfaces, XDM Interfaces*”.

5.1.3 OMA Push Enabler

The PAL Enabler makes use of the following Interfaces from the OMA Push Enabler:

- Push-PAP Interface is exposed by the Push Proxy Gateway and SHALL be used by a PAL Server as described in [PUSH_AD] “*The Push Access Protocol*”; and
- Push-CAI Interface is exposed by the Push Enabler and SHALL be used by a PAL Client to register as a Push application, and to receive notification of Push events from a Push Client as described in [PUSH_CAI] “*Push Client – Application Interface (Push-CAI)*”.

NOTE: The deployment, and configuration of a Push Client operating on behalf of a PAL specific Push application is out of scope of this Enabler.

5.2 Architectural Diagram

Figure 1 illustrates the OMA PAL architecture including interfaces applicable to the PAL Enabler.

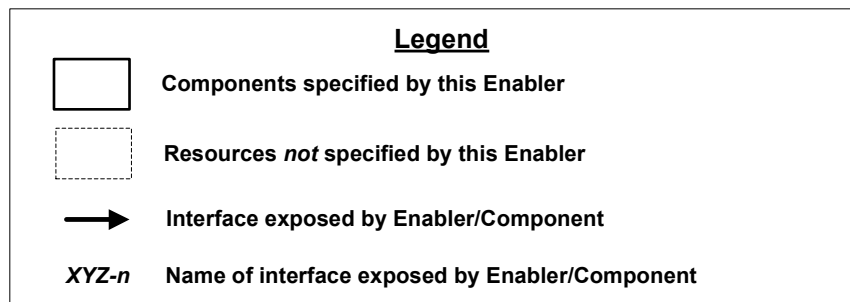
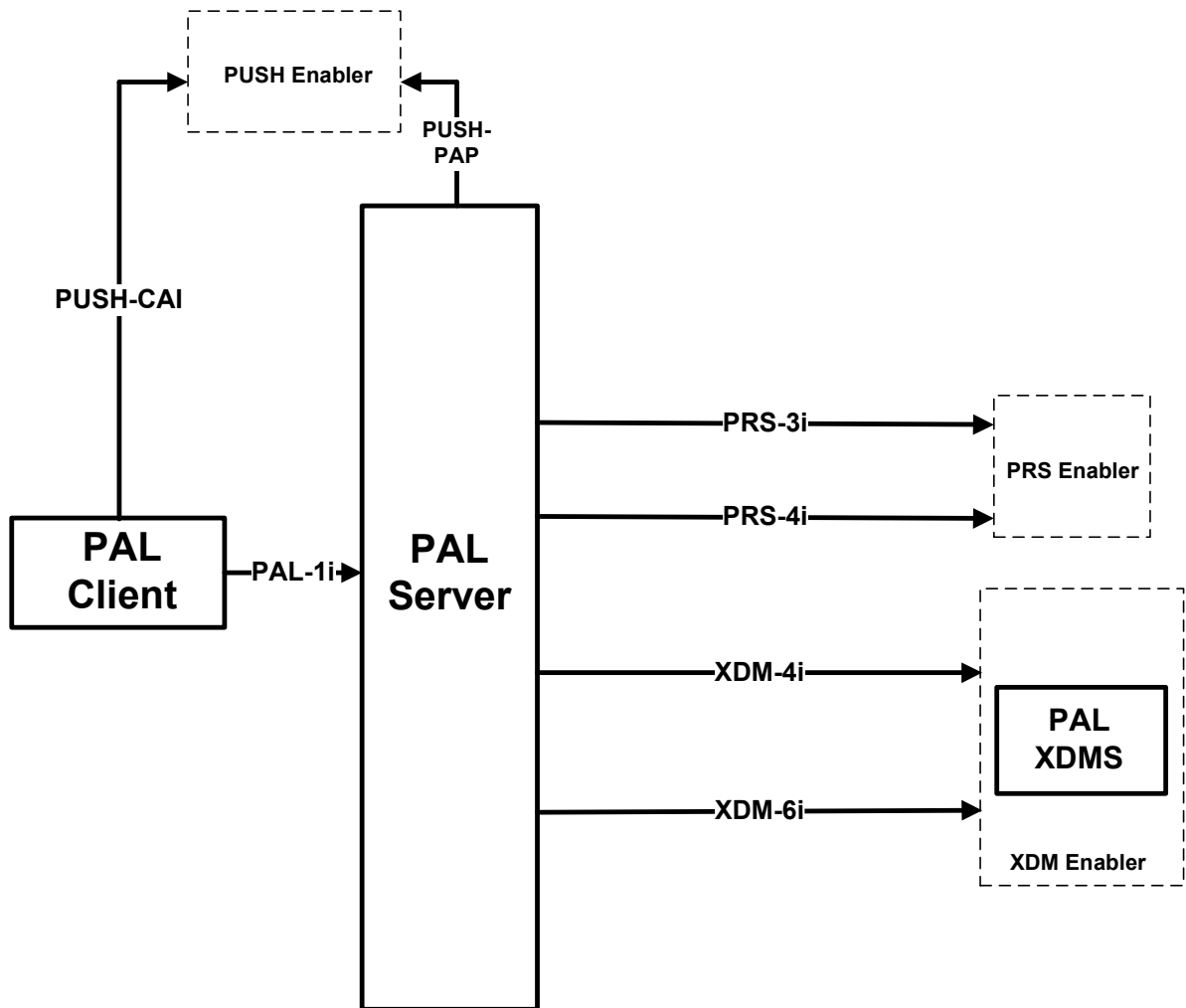

Figure 1: PAL Architecture Diagram

5.3 PAL Functional Components and Interfaces

This section describes PAL Functional Components and Interfaces identified in Figure 1.

The PAL Enabler exposes the following interface:

- PAL-Ii.

5.3.1 PAL Client

A PAL Client provides access to various features of a PAL Server, as detailed in section 5.3.2.

A PAL Client SHALL support the following functions:

- Requests to establish and receive a Presence Context (i.e. to fulfill underlying functionality of an application associated with a Presence Aware Service or Class of Service);
- Requests to receive Presence Aspects relative to a specified Presence Context;
- Requests to suspend or resume a Presence Context;
- Registers with the Push Enabler as a Push application (i.e. to receive asynchronous notifications); and
- Receives an asynchronous notification as a result of a pre-defined action corresponding to a Presence Trigger being invoked.

5.3.2 PAL Server

A PAL Server establishes Presence Context for an associated Presence Aware Service or Class of Service, in order to provide consolidated Presence Information (i.e. in the form of Presence Aspects) to authorized PAL Clients.

A PAL Server SHALL support the following functions:

- Authorizes requesting PAL Clients;
- Establishes or terminates a Presence Context associated with a Presence Aware Service or Class of Service, upon request;
- Subscribes to receive Presence Information for a Presentity, as a Watcher or Watcher Information Subscriber;
- Functions as a Home Subscription Agent (e.g. to limit the number of subscriptions to a Presence Server);
- Functions as a Push Initiator (i.e. to transmit asynchronous notifications);
- Manipulates (i.e. creates, retrieves, updates, and deletes) PAL Profiles as an XDM Agent;
- Subscribes to receive notification of changes to PAL Profiles, as an XDM Agent;
- Receives a Presence Aspect request; evaluates and applies PAL Policy to support the consolidation of Presence Information (i.e. in the form of Presence Aspects) for a Presence Aware Service and returns the result i.e. Presence Aspect values to the requesting PAL Client;
- Monitors, and detects Presence Aspect value changes associated with an applicable Presence Context, and executes predefined actions corresponding to a Presence Trigger e.g. notifies a PAL Client of such a Presence Aspect value change; and
- Suspends or resumes a Presence Context (i.e. suspend or resume asynchronous notifications of Presence Triggers applicable to a given Presence Context).

5.3.3 PAL XDMS

The PAL XDMS conforms to the specification for enabler specific XDMSs provided in [XDM_AD], section “*Enabler Specific XDMS*”. The PAL XDMS manages and supports the following XDM Documents:

- PAL Profile XDM Documents.

The PAL XDMS SHALL support the following functions:

- Manages PAL Profile XDM Documents (e.g. PAL Profiles) which are specific to the use of a PAL Server;
- Enables subscriptions to changes to PAL Profile XDM Documents stored in the PAL XDMS; and
- Notifies subscribers of changes to the PAL Profile XDM Documents stored in the PAL XDMS.

5.3.4 PAL-1i Interface

The PAL-1i Interface is exposed by a PAL Server, and supports the following functions on behalf of authorized principals, such as PAL Clients.

The PAL-1i Interface SHALL support PAL Initialization requests to enable a PAL Server to establish and resolve a Presence Context on behalf of authorized PAL Clients. The PAL Server processes a PAL Initialization request based on information provided (i.e. a Service XUI), and returns either a unique identifier associated with the resolved Presence Context, or an error response.

The PAL-1i Interface SHALL support Presence Aspect requests to retrieve consolidated views of Presence Information, in the form of Presence Aspect values from a PAL Server. A PAL Server processes a Presence Aspect request based on information provided (i.e. a Presence Context identifier, along with one or more Presence Aspects to be evaluated), and returns to the PAL Client; either Presence Aspect values corresponding to Presentities of interest, or an error response.

The PAL-1i Interface SHALL support a suspend (or resume) request in order to suspend or resume a Presence Context. For example a PAL Client suspends the receipt of Presence Aspects for a given Presence Context. A PAL Server processes a suspend/resume request based on information provided, i.e. a Presence Context identifier, and parameter information relating to the suspend/resume operation. A PAL Server then processes the requested operation, and based on the current state of the Presence Context, i.e. a request to suspend a Presence Context may be ignored if the given Presence Context is already in a suspended state. An appropriate suspend/resume response is returned to a PAL Client.

5.3.5 PAL Enabler Reference Points

The following sub-section provides details of PAL Enabler specific Reference Points. Descriptions of Reference Points reused from other Enablers are not within the scope of this architecture document, and are therefore omitted.

5.3.5.1 Reference Point PAL-1: PAL Client – PAL Server

The PAL-1 Reference Point supports communication between the PAL Client and PAL Server.

The PAL-1 Reference Point consists of the PAL-1i Interface.

5.3.6 PAL deployment - 3GPP IMS network

Figure 2, below, illustrates the PAL Enabler deployed within a 3GPP IMS network realization:

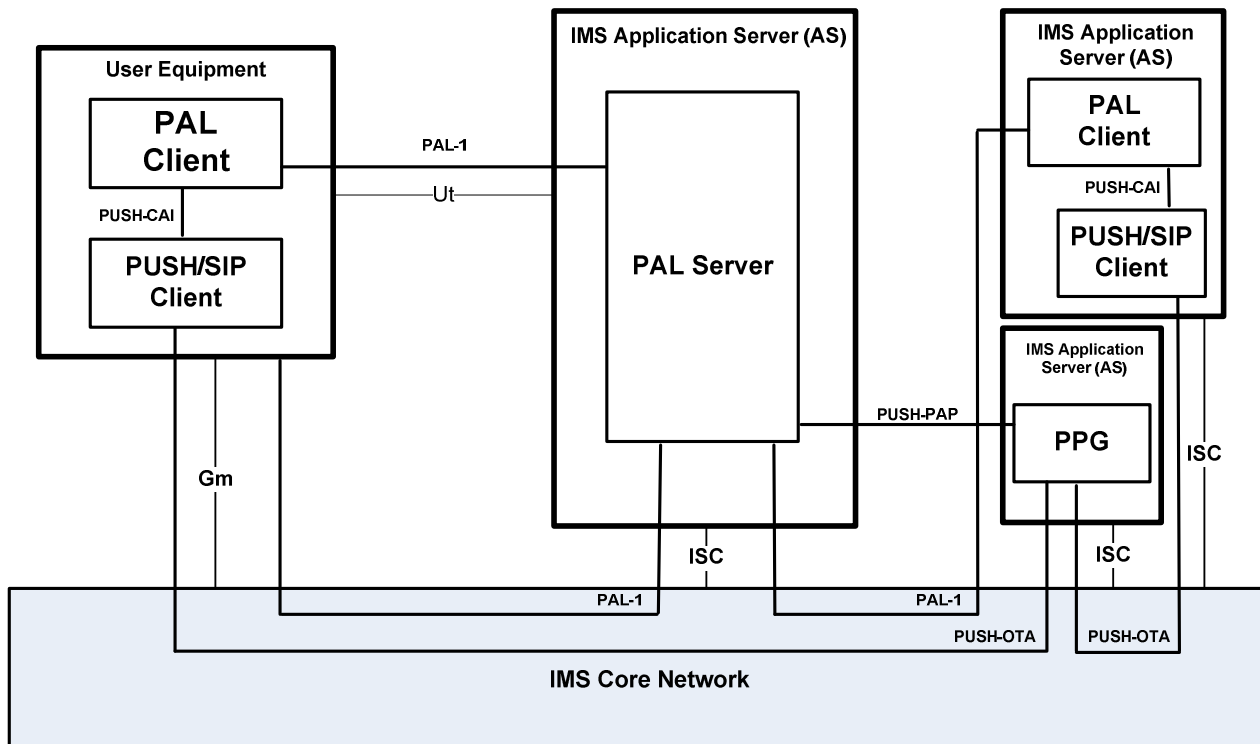

Figure 2: PAL Deployment – 3GPP IMS Network

The PAL Enabler deployed within an IMS network segment utilizes the following IMS Reference Points as defined in [3GPP-TS_23.002] section “*IM Subsystem Reference Points*” and [PUSH_SIP] section “*SIP Push Functional Components and Interfaces*”.

NOTE: Figure 2 assumes a PAL Client/Server running in an IMS Core Network utilizing SIP or HTTP protocol bindings and OMA Push Enabler (e.g. PUSH/SIP Client for PUSH-OTA over SIP protocol bindings).

The following table provides a mapping of 3GPP IMS CN Reference Points to OMA PAL Enabler Reference Points:

IMS Reference Point	OMA PAL Enabler Reference Point
Ut	PAL-1 (i.e. UE based PAL Clients supporting HTTP protocol bindings)
Gm	PAL-1 (i.e. UE based PAL Clients supporting SIP protocol bindings)
ISC	PAL-1 (i.e. PAL Functional Components supporting SIP protocol bindings)

5.4 Security Considerations

Security mechanisms may be employed by PAL Enabler deployments in order to prevent denial-of-service attacks and provide integrity of a PAL Service. These mechanisms may include:

- Mutual authentication of PAL Clients and PAL Server; and
- Authorization of PAL Clients.

Suitable authentication, authorization, message integrity, and confidentiality protection mechanisms may be used by PAL Enabler deployments, as described in [SEC_CF_AD].

Appendix A. Change History

(Informative)

A.1 Approved Version History

Reference	Date	Description
n/a	n/a	No prior version

A.2 Draft/Candidate Version 1.0 History

Document Identifier	Date	Sections	Description
Draft Versions OMA-AD-PAL-V1_0	15 Feb 2009	n/a	AD skeleton based on OMA-Template-ArchDoc-20090101-I
	29 Jun 2009	All	Incorporated CRs: OMA-PAG-PAL-2009-0033-CR_PAL_V1_0_AD_Scope OMA-PAG-PAL-2009-0045R01-CR_PAL_V1_0_AD_Introduction OMA-PAG-PAL-2009-0046R02-CR_PAL_V1_0_NormativeRefs OMA-PAG-PAL-2009-0048R02-CR_PAL_V1_0_PAL_ArchModel
	21 Jul 2009	2.1, 2.2, 5.1, 5.2	Incorporated CRs: OMA-PAG-PAL-2009-0054- CR_PAL_V1_0_AD_Addl_NormativeRefs OMA-PAG-PAL-2009-0055R01- CR_PAL_V1_0_AD_PAL_Dependencies OMA-PAG-PAL-2009-0056-CR_PAL_V1_0_AD_FixArchModel
	04 Aug 2009	3.1, 3.2, 5.3 App B.	Incorporated CRs: OMA-PAG-PAL-2009-0044R02- CR_PAL_V1_0_AD_Defs_And_Abbrevs OMA-PAG-PAL-2009-0047R04- CR_PAL_V1_0_AD_PAL_FuncComponents OMA-PAG-PAL-2009-0049R03- CR_PAL_V1_0_AD_PAL_AppB_Flow1
	10 Sep 2009	1, 2.1, 2.2, 3.2, 4, 4.1, 5.3, App B.	Incorporated CRs: OMA-PAG-PAL-2009-0058R02- CR_PAL_V1_0_AD_PAL_AppB_Flow2 OMA-PAG-PAL-2009-0060-CR_PAL_V1_0_AD_Fixes OMA-PAG-PAL-2009-0061R01- CR_PAL_V1_0_AD_ComponentFixes OMA-PAG-PAL-2009-0064R01- CR_CR_PAL_V1_0_AD_PAL_AppB_Flow3
	21 Sep 2009	2, 3, 4, App A and App B.	Incorporated CRs: Applied missing changes from OMA-PAG-PAL-2009-0060- CR_PAL_V1_0_AD_Fixes OMA-PAG-PAL-2009-0065- CR_PAL_V1_0_AD_PAL_AppB_Flow3_Fix Editorial clean-up by DSO of sections 2 and 3 and App A.
	11 Nov 2009	All	Incorporated CRs (PAL V1.0 ADRR): OMA-PAG-PAL-2009-0072R01, OMA-PAG-PAL-2009-0073, OMA-PAG-PAL-2009-0074, OMA-PAG-PAL-2009-0075R01, OMA-PAG-PAL-2009-0076R01, OMA-PAG-PAL-2009-0077R01, OMA-PAG-PAL-2009-0081
	25 Nov 2009	All	Incorporated CRs (PAL V1.0 ADRR): OMA-PAG-PAL-2009-0070R04, OMA-PAG-PAL-2009-0079R02, OMA-PAG-PAL-2009-0083R02, OMA-PAG-PAL-2009-0084R01
	10 Dec 2009	5.1.4, 5.3.2, 2.1, 2.2	Incorporated CR: OMA-PAG-PAL-2009-0097R01 Editorial formatting of references in 2.1 and 2.2

Document Identifier	Date	Sections	Description
Candidate Version OMA-AD-PAL-V1_0	26 Jan 2010	n/a	Status changed to Candidate by TP: TP ref# OMA-TP-2009-0569- INP_PAL_V1_0_AD_for_Candidate_Approval
Draft Versions OMA-AD-PAL-V1_0	04 Mar 2010	2.1, 3, 5	Incorporated CRs: OMA-PAG-PAL-2010-0017R02- CR_PAL_V1_0_AD_missing_client_actions OMA-PAG-PAL-2010-0018R02-CR_PAL_V1_0_AD_PushRevision OMA-PAG-PAL-2010-0019-CR_PAL_V1_0_AD_PushRefsDefs OMA-MWG-PRS-2010-0022- CR_PAL_V1_1_AD_FurtherPushChanges OMA-MWG-PRS-2010-0023R01- CR_PAL_V1_0_AD_UpdateRefsDefs
	07 Apr 2010	All	Incorporated CRs: OMA-COM-PRS-2010-0039R02.
	25 May 2010	All	Incorporated CRs: OMA-COM-PRS-2010-0063R02, OMA-COM-PRS-2010-0065, OMA-COM-PRS-2010-0066, OMA-COM-PRS-2010-0067R01, OMA-COM-PRS-2010-0068R02, Additional edits, including: <ul style="list-style-type: none"> Removal of editor's note in sub-section 5.3.2 (i.e. to close CONR B009/B010); Changes to defined terms (i.e. to close CONR B005); Minor edit to fix double-reference of [XDM_AD] (kept in Normative ref's sub-section); and, Consistency of references to XDM i.e. from XDM 2.1 to XDM 2.0.
	27 May 2010	All	Minor edits by PAL/AD Editor for consistency purposes.
	31 May 2010	A2	Update of 25 May history box Change of hyperlinks into crossreferences Language set to English UK.
Candidate Version OMA-AD-PAL-V1_0	17 Aug 2010	N/A	Status changed to Candidate by TP: TP ref# OMA-TP-2010-0333- INP_PAL_V1_0_ERP_and_ETR_for_Candidate_approval

Appendix B. Flows (informative)

The following subsections describe high-level logical information flows between Functional Components of the PAL architecture. These flows illustrate how Functional Components within the PAL architecture support various features and requirements of the PAL Enabler.

B.1 PAL Presence Context Establishment

The PAL Client for User Alice makes use of specific Presence Information in the form of Presence Aspects, for a Presence Aware Service (e.g. the MIMO IM Service). Presence Aspects are provided to a PAL Client relative to a given Presence Context. Presence Context includes PAL Presence Parameters. Presence Context specifies a presence environment and is required in order for a PAL Client to make use of Presence Information. A Presence Context is resolved by the PAL Server based on a Presence Aware Service or Class of Service as outlined in Figure 3 below:

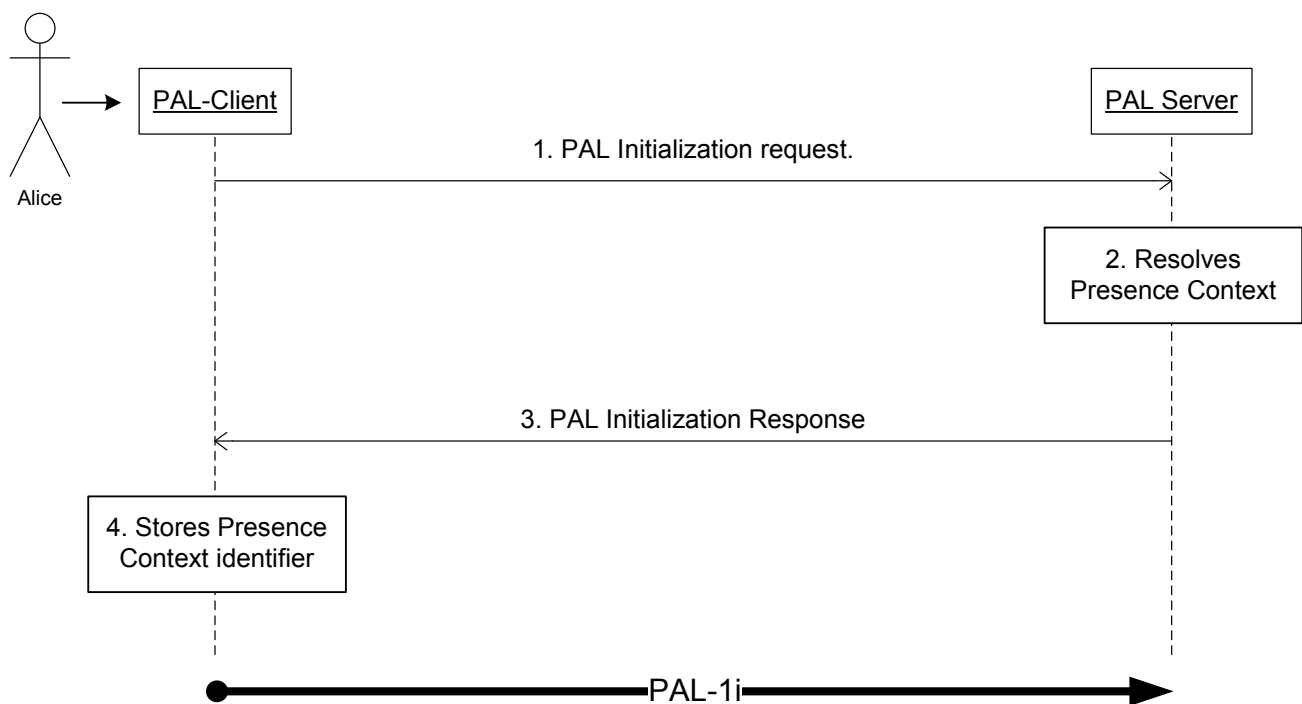

Figure 3: Establishing Presence Context based on a Presence Aware Service

1. A PAL Client that wishes to receive Presence Aspects, issues a PAL Initialization request to the PAL Server with the following information:
 - a. A Service XUI corresponding to a Presence Aware Service or Class of Service
 - b. The public user identity of the corresponding PAL Client (e.g. a SIP URI corresponding with user Alice)
 - c. An optional resource URI corresponding to the Presentity (e.g. a SIP URI)
2. Upon receipt of a PAL Initialization request, a PAL Server authorizes the request and resolves an appropriate PAL Presence Context based on a service identifier and optionally watcher-id and/or resource URI.
3. Once a Presence Context has been established, a PAL Server returns a PAL initialization response to a PAL Client, including a unique Presence Context identifier, and optional meta-data (e.g. a baseline Presence Aspect value).
4. A PAL Client stores the Presence Context identifier (and optional meta-data). Alice's IM Service is now able to request and make use of Presence Aspects relative to the established Presence Context.

B.2 Requesting specific Presence Information.

A PAL Client within Alice's mobile device, has stored and resolved a Presence Context for a Presence Aware Service 'MyFriendlyChat' from the PAL Server running within Alice's home network domain. Alice's MyFriendlyChat application may now request and make use of specific Presence Information through a PAL Client. Presence Aspects provide a PAL Client with a view of Presence Information based on an associated Presence Context, corresponding with one or more Presentities. Figure 4 below, provides an outline of a PAL Client retrieving a Presence Aspect, given an established Presence Context:

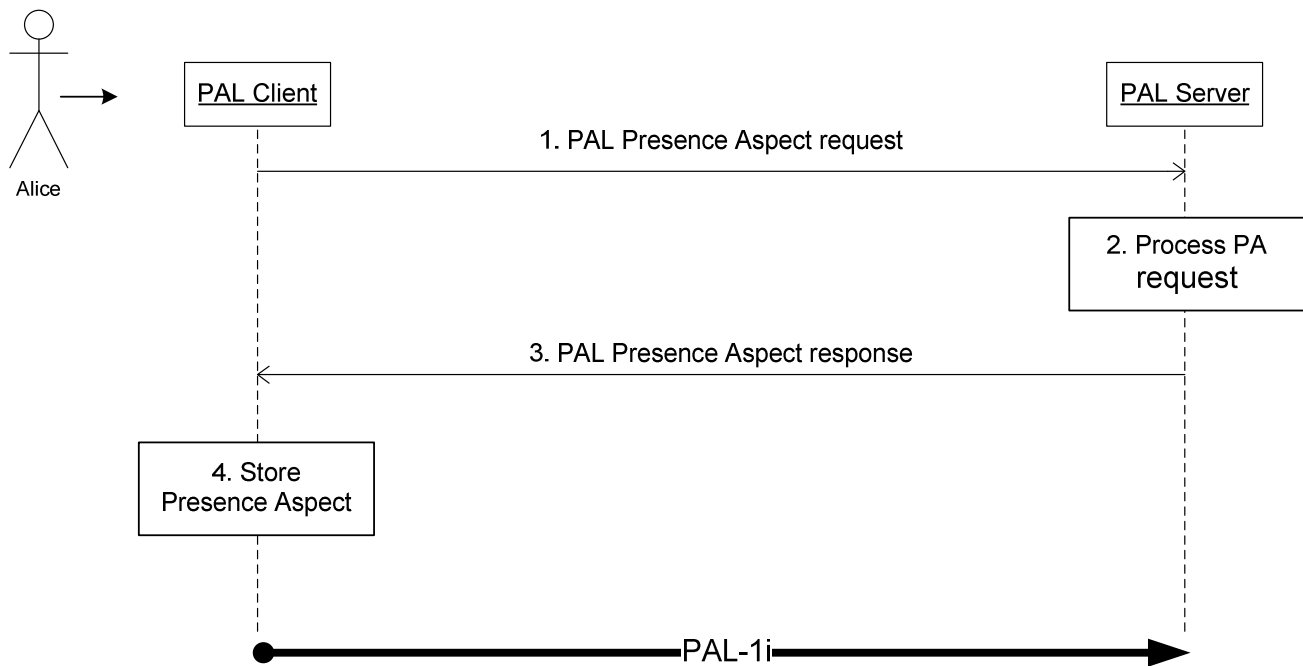

Figure 4: Requesting a Presence Aspect relative to a Presence Context

1. A PAL Client wishing to make use of Presence Aspects sends a PAL Presence Aspect request to the PAL Server with the following information:
 - a. A PAL Presence Context identifier corresponding to a particular Presence Aware Service or Class of Service;
 - b. A resource URI corresponding to the Presentity (e.g. a SIP URI); and,
 - c. The Presence Aspect being requested (e.g. 'contactable').
2. Upon receipt of a PAL Presence Aspect request, the PAL Server authorizes the request and proceeds to evaluate and/or retrieve the requested Presence Aspect associated with the Presence Context.
3. Once a Presence Context has been computed, the PAL Server issues a PAL Presence Aspect response to the PAL Client which includes the Presence Context identifier, and the Presence Aspect value.
4. The PAL Client stores the Presence Aspect corresponding to the given Presence Context which may then be provided to a Presence Aware Service such as 'MyFriendlyChat'.

B.3 Presence Trigger Predefined Action

A PAL Client within Anthony's mobile device wishes to receive alerts relating to detected status changes from his daughter Josephine, who is currently away from home attending college. Anthony's mobile device requests and stores a Presence Context for the 'Parental Alert' Presence Aware Service from a PAL Server running within his home network domain. As a result of this request, one or more Presence Triggers are established on behalf of Anthony for individuals of interest (e.g. his daughter Josephine) based on the resolved Presence Context. A Presence Trigger executes a predefined action as a result of a detected Presence Aspect change. Predefined actions may include sending an interested observer, such as Anthony, a notification providing details of the detected Presence Aspect change. Figure 5 below, provides an outline of a PAL Client establishing a Presence Context, and later receiving a detected change to a specified Presence Aspect value for an individual of interest based on the established Presence Context:

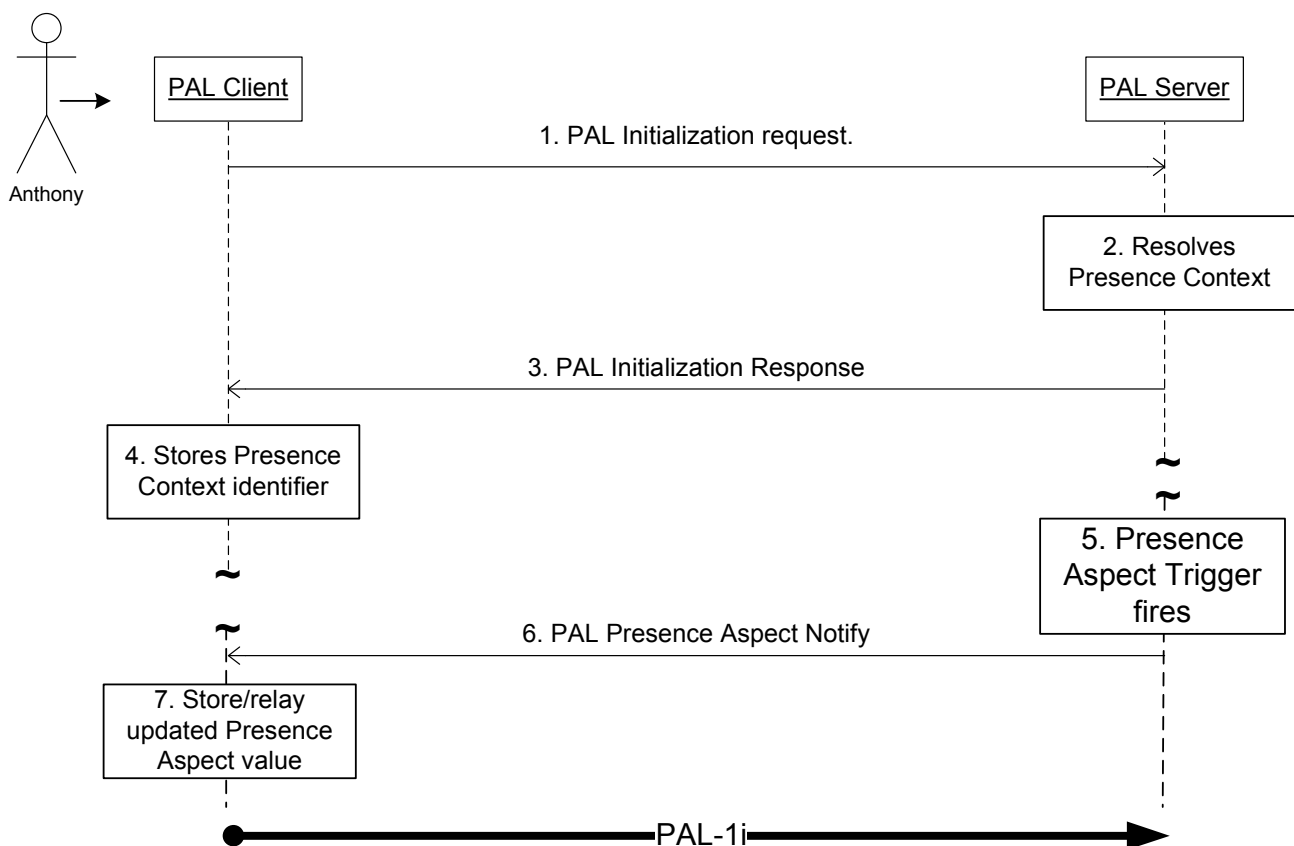

Figure 5: Receiving a Predefined Action corresponding with a Presence Trigger

For brevity, steps 1-4 are omitted. Further details on establishing a Presence Context are as described in Appendix B.1.

5. A PAL Server monitoring Presence Aspects corresponding with a given Presence Context detects a Presence Aspect change associated with a specific Presence Trigger (e.g. 'onAvailable') for Presentities of interest. As a result, the predefined Presence Trigger action fires.
6. This results in a notification being sent to the PAL Client. This notification may include the following information:
 - a. A PAL Presence Context identifier corresponding to a particular Presence Aware Service or Class of Service;
 - b. A resource URI corresponding to the Presentity (e.g. a SIP URI); and,
 - c. The detected Presence Aspect value (e.g. Josephine is now considered 'available').

7. The PAL Client stores the detected Presence Aspect value change corresponding to the given Presence Context which may then be relayed to a Presence Aware Service such as 'Parental Alert'.