



# **XML Document Management Architecture**

Approved Version 2.0 – 03 Apr 2012

---

**Open Mobile Alliance**  
OMA-AD-XDM-V2\_0-20120403-A

Use of this document is subject to all of the terms and conditions of the Use Agreement located at <http://www.openmobilealliance.org/UseAgreement.html>.

Unless this document is clearly designated as an approved specification, this document is a work in process, is not an approved Open Mobile Alliance™ specification, and is subject to revision or removal without notice.

You may use this document or any part of the document for internal or educational purposes only, provided you do not modify, edit or take out of context the information in this document in any manner. Information contained in this document may be used, at your sole risk, for any purposes. You may not use this document in any other manner without the prior written permission of the Open Mobile Alliance. The Open Mobile Alliance authorizes you to copy this document, provided that you retain all copyright and other proprietary notices contained in the original materials on any copies of the materials and that you comply strictly with these terms. This copyright permission does not constitute an endorsement of the products or services. The Open Mobile Alliance assumes no responsibility for errors or omissions in this document.

Each Open Mobile Alliance member has agreed to use reasonable endeavors to inform the Open Mobile Alliance in a timely manner of Essential IPR as it becomes aware that the Essential IPR is related to the prepared or published specification. However, the members do not have an obligation to conduct IPR searches. The declared Essential IPR is publicly available to members and non-members of the Open Mobile Alliance and may be found on the “OMA IPR Declarations” list at <http://www.openmobilealliance.org/ipr.html>. The Open Mobile Alliance has not conducted an independent IPR review of this document and the information contained herein, and makes no representations or warranties regarding third party IPR, including without limitation patents, copyrights or trade secret rights. This document may contain inventions for which you must obtain licenses from third parties before making, using or selling the inventions. Defined terms above are set forth in the schedule to the Open Mobile Alliance Application Form.

NO REPRESENTATIONS OR WARRANTIES (WHETHER EXPRESS OR IMPLIED) ARE MADE BY THE OPEN MOBILE ALLIANCE OR ANY OPEN MOBILE ALLIANCE MEMBER OR ITS AFFILIATES REGARDING ANY OF THE IPR'S REPRESENTED ON THE “OMA IPR DECLARATIONS” LIST, INCLUDING, BUT NOT LIMITED TO THE ACCURACY, COMPLETENESS, VALIDITY OR RELEVANCE OF THE INFORMATION OR WHETHER OR NOT SUCH RIGHTS ARE ESSENTIAL OR NON-ESSENTIAL.

THE OPEN MOBILE ALLIANCE IS NOT LIABLE FOR AND HEREBY DISCLAIMS ANY DIRECT, INDIRECT, PUNITIVE, SPECIAL, INCIDENTAL, CONSEQUENTIAL, OR EXEMPLARY DAMAGES ARISING OUT OF OR IN CONNECTION WITH THE USE OF DOCUMENTS AND THE INFORMATION CONTAINED IN THE DOCUMENTS.

© 2012 Open Mobile Alliance Ltd. All Rights Reserved.

Used with the permission of the Open Mobile Alliance Ltd. under the terms set forth above.

# Contents

<b>1. SCOPE (INFORMATIVE)</b> .....	<b>5</b>
<b>2. REFERENCES</b> .....	<b>6</b>
<b>2.1 NORMATIVE REFERENCES</b> .....	<b>6</b>
<b>2.2 INFORMATIVE REFERENCES</b> .....	<b>7</b>
<b>3. TERMINOLOGY AND CONVENTIONS</b> .....	<b>8</b>
<b>3.1 CONVENTIONS</b> .....	<b>8</b>
<b>3.2 DEFINITIONS</b> .....	<b>8</b>
<b>3.3 ABBREVIATIONS</b> .....	<b>8</b>
<b>4. INTRODUCTION (INFORMATIVE)</b> .....	<b>10</b>
<b>4.1 PLANNED PHASES</b> .....	<b>10</b>
<b>4.2 SECURITY CONSIDERATIONS</b> .....	<b>11</b>
<b>5. ARCHITECTURAL MODEL</b> .....	<b>12</b>
<b>5.1 ARCHITECTURAL DIAGRAM</b> .....	<b>12</b>
<b>5.2 FUNCTIONAL ENTITIES</b> .....	<b>13</b>
<b>5.2.1 XDM Functional Entities</b> .....	<b>13</b>
5.2.1.1 <i>XDMC</i> .....	13
5.2.1.2 <i>Aggregation Proxy</i> .....	13
5.2.1.3 <i>Subscription Proxy</i> .....	14
5.2.1.4 <i>Search Proxy</i> .....	14
5.2.1.5 <i>Cross-Network Proxy</i> .....	14
5.2.1.6 <i>XDMs</i> .....	14
<b>5.2.2 External Functional Entities Providing Services to XDM</b> .....	<b>16</b>
5.2.2.1 <i>SIP/IP Core</i> .....	16
5.2.2.2 <i>Device Management Enabler</i> .....	16
5.2.2.3 <i>Charging Enabler</i> .....	16
<b>5.3 DESCRIPTION OF REFERENCE POINTS</b> .....	<b>16</b>
<b>5.3.1 XDM Reference Points</b> .....	<b>16</b>
5.3.1.1 <i>Reference Point XDM-1: Untrusted XDMC – SIP/IP Core</i> .....	16
5.3.1.2 <i>Reference Point XDM-2: XDMs – SIP/IP-Core</i> .....	17
5.3.1.3 <i>Reference Point XDM-3: Untrusted XDMC – Aggregation Proxy</i> .....	17
5.3.1.4 <i>Reference Point XDM-4: Aggregation Proxy – XDMs</i> .....	17
5.3.1.5 <i>Reference Point XDM-5: Untrusted XDMC – Aggregation Proxy</i> .....	17
5.3.1.6 <i>Reference Point XDM-6: Aggregation Proxy – Search Proxy</i> .....	18
5.3.1.7 <i>Reference Point XDM-7: Search Proxy – XDMs</i> .....	18
5.3.1.8 <i>Reference Point XDM-8: Aggregation Proxy – Cross-Network Proxy</i> .....	18
5.3.1.9 <i>Reference Point XDM-9: Search Proxy – Cross-Network Proxy</i> .....	18
5.3.1.10 <i>Reference Point XDM-10: Subscription Proxy – SIP/IP Core</i> .....	18
5.3.1.11 <i>Reference Point XDM-11: Trusted XDMC - Aggregation Proxy</i> .....	19
5.3.1.12 <i>Reference Point XDM-12: Trusted XDMC – SIP/IP Core</i> .....	19
5.3.1.13 <i>Reference Point XDM-13: Trusted XDMC - Search Proxy</i> .....	19
5.3.1.14 <i>Reference Point XDM-14: Trusted XDMC – XDMs</i> .....	19
5.3.1.15 <i>Reference Point NNI-1: Cross-Network Proxy – Cross-Network Proxy of remote network</i> .....	20
<b>5.3.2 External Reference Points Providing Services to XDM</b> .....	<b>20</b>
5.3.2.1 <i>Reference Point IP-1: SIP/IP Core – SIP/IP Core of remote network</i> .....	20
<b>5.4 DESCRIPTION OF INTERFACES</b> .....	<b>20</b>
<b>5.4.1 XDM Interfaces</b> .....	<b>20</b>
5.4.1.1 <i>Interface XDM-2i: XDMs</i> .....	20
5.4.1.2 <i>Interface XDM-3i: Aggregation Proxy</i> .....	20
5.4.1.3 <i>Interface XDM-4i: XDMs</i> .....	20
5.4.1.4 <i>Interface XDM-5i: Aggregation Proxy</i> .....	21
5.4.1.5 <i>Interface XDM-6i: Search Proxy</i> .....	21
5.4.1.6 <i>Interface XDM-7i: XDMs</i> .....	21
5.4.1.7 <i>Interface XDM-8.1i: Cross-Network Proxy</i> .....	21
5.4.1.8 <i>Interface XDM-8.2i: Aggregation Proxy</i> .....	21
5.4.1.9 <i>Interface XDM-9i: Cross-Network Proxy</i> .....	22
5.4.1.10 <i>Interface XDM-10i: Subscription Proxy</i> .....	22

5.4.1.11 Interface XDM-15i: Cross-Network Proxy ..... 22

5.4.1.12 Interface XDM-16i: Cross-Network Proxy ..... 22

**5.4.2 External Interfaces used by the XDM enabler ..... 22**

5.4.2.1 Interface SIC-1: SIP/IP Core ..... 22

5.4.2.2 Interface SIC-2: SIP/IP Core ..... 23

5.4.2.3 Interface SIC-3: SIP/IP Core ..... 23

5.4.2.4 Interfaces CH-1/CH-2: Charging Enabler ..... 23

**6. BACKWARD COMPATIBILITY TOWARDS THE XDM ENABLER VERSION 1.1 AND THE POC ENABLER VERSION 1.0. .... 25**

**APPENDIX A. CHANGE HISTORY (INFORMATIVE) ..... 27**

A.1 APPROVED VERSION 2.0 HISTORY ..... 27

**APPENDIX B. HOW TO SHOW RE-USE OF THE XDM ENABLER (INFORMATIVE) ..... 28**

## Figures

Figure 1: XDM Architecture using Reference Points ..... 12

Figure 2: XDM Architecture using Interfaces ..... 13

Figure 3: XDM Enabler Use of the Charging Enabler’s CH-1 and CH-2 Interfaces ..... 24

Figure 4: Complete XDM architecture that can be reused by an Enabler ..... 29

Figure 5: How an Enabler should depict reuse of the XDM enabler. .... 29

# 1. Scope

**(Informative)**

This document presents an overview of the XML Document Management (XDM) enabler release 2.0. Specifically, it serves as an introduction to the functionality and architecture of the XDM enabler.

## 2. References

### 2.1 Normative References

- [3GPP2-X.S0013-000] 3GPP2 X.S0013-000 “All-IP Core Network Multimedia Domain: Overview”,  
URL: [http://www.3gpp2.org/Public\\_html/specs/index.cfm](http://www.3gpp2.org/Public_html/specs/index.cfm)
- [3GPP2-X.S0013-002] 3GPP2 X.S0013-002 “All-IP Core Network Multimedia Domain: IP Multimedia Subsystem - Stage 2”,  
URL: [http://www.3gpp2.org/Public\\_html/specs/index.cfm](http://www.3gpp2.org/Public_html/specs/index.cfm)
- [3GPP-TS\_23.002] 3GPP TS 23.002 “Network architecture”,  
URL: [http://www.3gpp.org/ftp/Specs/archive/23\\_series/23.002/](http://www.3gpp.org/ftp/Specs/archive/23_series/23.002/)
- [3GPP-TS\_23.228] 3GPP TS 23.228 “IP Multimedia Subsystem (IMS); Stage 2”,  
URL: [http://www.3gpp.org/ftp/Specs/archive/23\\_series/23.228/](http://www.3gpp.org/ftp/Specs/archive/23_series/23.228/)
- [Charging\_AD] “Charging Architecture”, Version 1.0, Open Mobile Alliance™, OMA-AD-Charging-V1\_0,  
URL: <http://www.openmobilealliance.org/>
- [Dict] “Dictionary for OMA Specifications”, Version 2.4, Open Mobile Alliance™, OMA-ORG-Dictionary-V2\_4,  
URL: <http://www.openmobilealliance.org/>
- [DM\_Bootstrap] “OMA Device Management Bootstrap”, Version 1.2, Open Mobile Alliance™, OMA-TS-DM\_Bootstrap-V1\_2,  
URL: <http://www.openmobilealliance.org/>
- [DM\_ERELD] “Enabler Release Definition for OMA Device Management”, Version 1.2, Open Mobile Alliance™, OMA-ERELED-DM-V1\_2,  
URL: <http://www.openmobilealliance.org/>
- [IM\_ERELD-V1\_0] “Enabler Release Definition for SIMPLE IM”, Draft Version 1.0, Open Mobile Alliance™, OMA-ERELED-SIMPLE\_IM-V1\_0,  
URL: <http://www.openmobilealliance.org/>
- [PoC\_AD-V1\_0] “Push to talk over Cellular (PoC) – Architecture”, Version 1.0, Open Mobile Alliance™, OMA-AD-PoC-V1\_0,  
URL: <http://www.openmobilealliance.org/>
- [PoC\_ERELD-V1\_0] “Enabler Release Definition for Push-to-Talk over Cellular”, Version 1.0, Open Mobile Alliance™, OMA-ERELED-POC-V1\_0,  
URL: <http://www.openmobilealliance.org/>
- [PoC\_ERELD-V2\_0] “Enabler Release Definition for Push-to-Talk over Cellular”, Draft Version 2.0, Open Mobile Alliance™, OMA-ERELED-POC-V2\_0,  
URL: <http://www.openmobilealliance.org/>
- [RFC2119] IETF RFC 2119 “Key words for use in RFCs to Indicate Requirement Levels”, S. Bradner, March 1997,  
URL: <http://www.ietf.org/rfc/rfc2119.txt>
- [RFC4662] IETF RFC 4662 “A Session Initiation Protocol (SIP) Event Notification Extension for Resource Lists”, A. B. Roach, B. Campbell, J. Rosenberg, August 2006,  
URL: <http://www.ietf.org/rfc/rfc4662.txt>
- [RFC5875] IETF RFC 5875 “An Extensible Markup Language (XML) Configuration Access Protocol (XCAP) Diff Event Package”, J. Urpalainen, D. Willis, May 2010,  
URL: <http://www.ietf.org/rfc/rfc5875.txt>
- [XDM\_ERELD-V1\_1] “Enabler Release Definition for XML Document Management”, Version 1.1, Open Mobile Alliance™, OMA-ERELED-XDM-V1\_1,  
URL: <http://www.openmobilealliance.org/>

- [XDM\_ERELD-V2\_0] “Enabler Release Definition for XML Document Management”, Version 2.0, Open Mobile Alliance™, OMA-ERELD-XDM-V2\_0,  
URL: <http://www.openmobilealliance.org/>
- [XDM\_RD] “XML Document Management Requirements”, Version 2.0, Open Mobile Alliance™, OMA-RD-XDM-V2\_0,  
URL: <http://www.openmobilealliance.org/>

## 2.2 Informative References

- [3GPP-TS\_33.222] 3GPP TS 33.222 “Generic Authentication Architecture (GAA); Access to network application functions using Hypertext Transfer Protocol over Transport Layer Security (HTTPS)”,  
URL: [http://www.3gpp.org/ftp/Specs/archive/33\\_series/33.222/](http://www.3gpp.org/ftp/Specs/archive/33_series/33.222/)
- [PRS\_ERELD-V1\_1] “Enabler Release Definition for OMA Presence SIMPLE”, Version 1.1, Open Mobile Alliance™, OMA-ERELD-Presence\_SIMPLE-V1\_1,  
URL: <http://www.openmobilealliance.org/>
- [RFC3324] IETF RFC 3324 “Short Term Requirements for Network Asserted Identity”, M. Watson, November 2002,  
URL: <http://www.ietf.org/rfc/rfc3324.txt>
- [RFC4825] IETF RFC 4825 “The Extensible Markup Language (XML) Configuration Access protocol (XCAP)”, J. Rosenberg, May 2007,  
URL: <http://www.ietf.org/rfc/rfc4825.txt>
- [W3C-XQUERY] W3C Recommendation “XQuery 1.0: An XML Query Language”, Scott Boag et al, January 23 2007, World Wide Web Consortium (W3C),  
URL: <http://www.w3.org/TR/xquery>

## 3. Terminology and Conventions

### 3.1 Conventions

The key words “MUST”, “MUST NOT”, “REQUIRED”, “SHALL”, “SHALL NOT”, “SHOULD”, “SHOULD NOT”, “RECOMMENDED”, “MAY”, and “OPTIONAL” in this document are to be interpreted as described in [RFC2119].

All sections and appendixes, except “Scope” and “Introduction”, are normative, unless they are explicitly indicated to be informative.

### 3.2 Definitions

<b>Chargeable Event</b>	A service delivery that has taken place, and can be specified and recorded. (Source: [Dict])
<b>Interface</b>	The common boundary between two associated systems. (Source: [Dict])
<b>Group Usage List</b>	Use definition from [XDM_RD]
<b>Limited XQuery over HTTP</b>	The subset of XQuery functions that are used in OMA XDM search requests.
<b>Primary Principal</b>	The Primary Principal is the user associated with the XCAP User Identity, which defines where the document resides.
<b>Principal</b>	An entity that has an identity, that is capable of providing consent and other data, and to which authenticated actions are done on its behalf. Examples of Principals include an individual user, a group of individuals, a corporation, service enablers/applications, system entities and other legal entities. (Source: [Dict])
<b>Reference Point</b>	A conceptual point at the conjunction of two non-overlapping functional groups (source: ITU-T I.112). It consists of none or any number of Interfaces of any kind. (Source: [Dict])
<b>Resource List Meta-Information</b>	A document describing the state of virtual subscriptions associated with a list subscription. (Source: [RFC4662])
<b>Resource List Server</b>	RLSes accept subscriptions to resource lists and send notifications to update subscribers of the state of the resources in a resource list. (Source: [RFC4662])
<b>Shared Group</b>	Use definition from [XDM_RD]
<b>Shared User Access Policy</b>	A User Access Policy as described in [XDM_RD] section “ <i>Shared User Access Policy Document</i> ”
<b>Shared URI List</b>	Use definition from [XDM_RD]
<b>Shared User Profile</b>	Use definition from [XDM_RD]
<b>Shared XDMSs</b>	A logical entity to group XDMSs defined by the XDM enabler.
<b>Trusted Network</b>	A network that consists of elements that are trusted (i.e. are not required to authenticate themselves). It corresponds to the definition of 'Trust Domain' as defined in [RFC3324].
<b>Trusted XDMC</b>	An XDMC that uses XDM interfaces that do not require security mechanisms, typically deployed within Trusted Networks
<b>Untrusted XDMC</b>	An XDMC that uses XDM interfaces that require security mechanisms such as authentication, typically deployed outside of Trusted Networks
<b>XCAP Resource</b>	An HTTP resource representing an XML document, an element within an XML document, or an attribute of an element within an XML document that follows the naming and validation constraints of XCAP. (Source: [RFC4825])

### 3.3 Abbreviations

**DM** Device Management



---

<b>GAA</b>	Generic Authentication Architecture
<b>HTTP</b>	Hyper Text Transfer Protocol
<b>IETF</b>	Internet Engineering Task Force
<b>IP</b>	Internet Protocol
<b>OMA</b>	Open Mobile Alliance
<b>PoC</b>	Push to talk over Cellular
<b>RLMI</b>	Resource List Meta-Information
<b>RLS</b>	Resource List Server
<b>SIC</b>	SIP/IP Core
<b>SIP</b>	Session Initiation Protocol
<b>TLS</b>	Transport Layer Security
<b>UE</b>	User Equipment
<b>XCAP</b>	XML Configuration Access Protocol
<b>XDM</b>	XML Document Management
<b>XDMC</b>	XML Document Management Client
<b>XDMS</b>	XML Document Management Server
<b>XML</b>	Extensible Markup Language
<b>XQuery</b>	XML Query

## 4. Introduction

(Informative)

This Architecture Document describes the features and architecture of the OMA XDM enabler.

The XDM enabler defines a common mechanism that makes user-specific service-related information accessible to the service enablers that need them. Such information is expected to be stored in the network where it can be located, accessed and manipulated (e.g. created, changed, deleted, etc.). XDM specifies how such information will be defined in well-structured XML documents, as well as the common protocol for access and manipulation of such XML documents.

The XDM Requirement Specification [XDM\_RD] defines the features of the XDM enabler, which include the following:

- Document management functions by which Principals can store and manipulate their service-related data, stored in a network as XML documents;
- Subscription/notification mechanism by which Principals can be notified of changes to such documents; and
- Search mechanism by which Principals can search service-related data stored in a network as XML documents using limited XQuery [W3C-XQUERY] request.

Documents accessed and manipulated via XCAP [RFC4825] are stored in logical repositories in the network, called XDMS. Each repository may be associated with a functional entity which uses its data to perform its functions.

Each XML document stored in an XDMS is described as an XCAP Application Usage, which enables applications to use the document via XCAP. The XDM enabler describes Application Usages which can be reused by multiple enablers and are stored in the Shared XDMSs, of which there are four types: Shared List XDMS, Shared Group XDMS, Shared Policy XDMS and Shared Profile XDMS. The documents supported by these XDMSs are as follows:

- Shared URI List and Group Usage List documents in the Shared List XDMS;
- Shared Group document in the Shared Group XDMS;
- Shared User Access Policy document in the Shared Policy XDMS; and
- Shared User Profile document in the Shared Profile XDMS.

In addition to above documents the XDM Enabler also defines the Extended Group Advertisement function [XDM\_RD].

Due to the reusable nature of the XDM enabler, there will be interactions with other service enablers, and therefore, the architectural design of the XDM enabler accommodates the needs of those enablers.

The Architecture Document also describes aspects on backward compatibility towards the XDM Enabler version 1.1 [XDM\_ERELD-V1\_1] and the PoC Enabler version 1.0 [PoC\_ERELD-V1\_0] concerning XML document handling.

### 4.1 Planned Phases

This release of XDM enabler is targeted to support the OMA application enablers of SIMPLE IM V1.0 [IM\_ERELD-V1\_0] and PoC V2.0 [PoC\_ERELD-V2\_0]. This release of XDM enabler is also backward compatible with earlier versions of PoC V1.0 [PoC\_ERELD-V1\_0], Presence SIMPLE V1.1 [PRS\_ERELD-V1\_1] and XDM V1.1 [XDM\_ERELD-V1\_1]

To accommodate this, this release of XDM enabler:

- Inherits Shared XDMS from [XDM\_ERELD-V1\_1] and rename it as Shared List XDMS, which SHALL be fully backward compatible with earlier versions of XDM, PoC and Presence SIMPLE Enablers;
- Inherits PoC Group document in PoC XDMS from [PoC\_ERELD-V1\_0] and extends it as reusable Group document in Shared Group XDMS, which SHALL be fully backward compatible with earlier versions of XDM and PoC Enablers;
- Inherits PoC User Access Policy document in PoC XDMS from [PoC\_ERELD-V1\_0] and extends it as reusable User Access Policy document in Shared Policy XDMS, which SHALL be fully backward compatible with earlier versions of XDM and PoC Enablers;
- Defines new Shared Profile XDMS; and

- Inherits PoC Group Advertisement [PoC\_ERELD-V1\_0] and extends it as reusable Extended Group Advertisement for other enablers, which SHALL be fully backward compatible with earlier version of PoC Enabler.

Also, while inheriting all features from [XDM\_ERELD-V1\_1], this release of XDM enabler supports the following features:

- Search for information in documents stored in an XDMS;
- Subscription for notification of changes in XML documents stored in an XDMS; and
- Network-to-network interface to enable search of information across XDMS of multiple domains and retrieval of document from remote network.

The following features are planned to be supported in the future release of XDM enabler:

- Extended search for information in documents stored in multiple XDMSs and enabler specific servers;
- Extended document management operations including copy, forward, suspend, resume;
- Document access control for all kinds of document management operations and delegation of document access control rights to other users;
- Document change history management;
- Extended network-to-network interface support for all kinds of operations; and
- Other features as identified in the future.

## 4.2 Security Considerations

The XDMC is to be authenticated when accessing the XDM service

- For an XDMC residing within a Trusted Network, authorisation in an XDMS is based on received identity information.
- For an XDMC residing outside a Trusted Network, TLS is used as specified in [RFC4825] in order to provide integrity and confidentiality protection to the exchanged messages. HTTP Digest is the default authentication mechanism as specified in [RFC4825]. For a 3GPP realisation the Generic Authentication Architecture (GAA) can be used as an underlying network mechanism as specified in [3GPP-TS\_33.222].

# 5. Architectural Model

## 5.1 Architectural Diagram

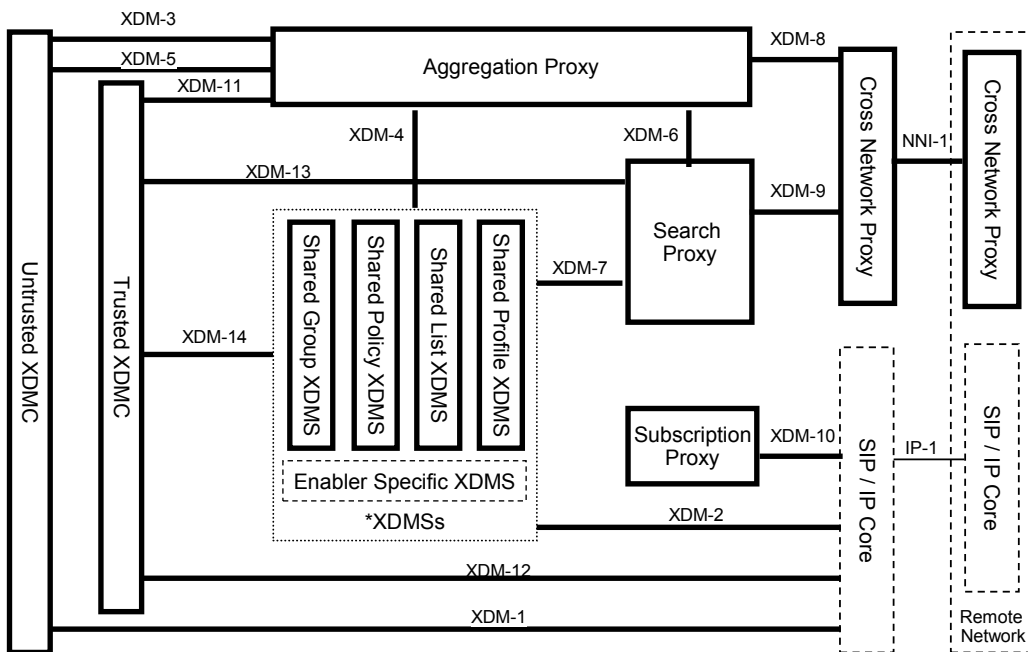

Dashed Boxes are not specified by the XDM enabler.  
 \*XDMs is a logical entity to map XDMs together for simplification

**Figure 1: XDM Architecture using Reference Points**

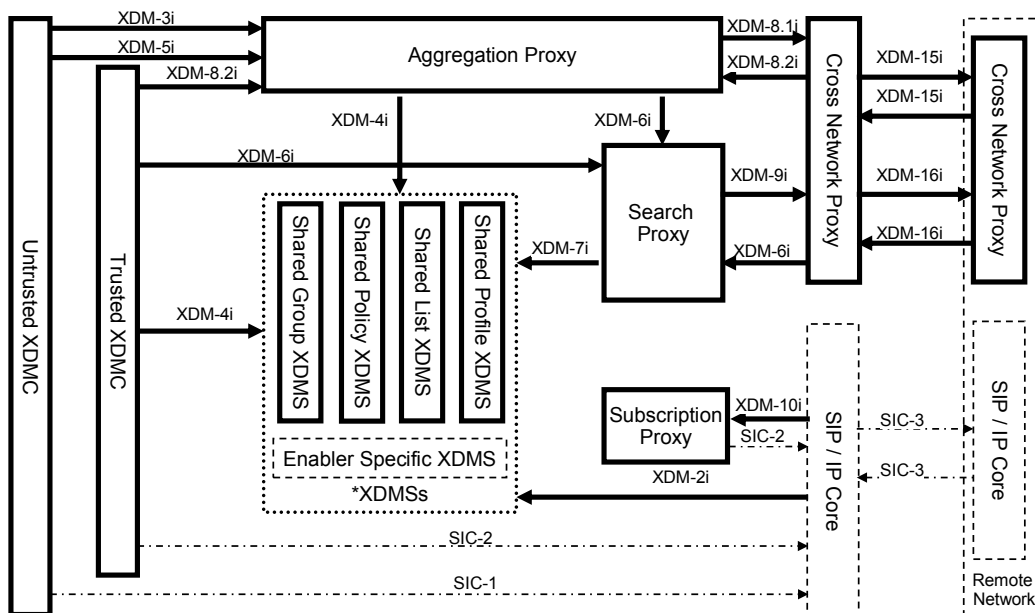

Chain dashed line are used for I2 Interfaces reused by the XDM enabler  
 Dashed Boxes are not specified by the XDM enabler  
 \*XDMs is a logical entity to map XDMs together for simplification

Figure 2: XDM Architecture using Interfaces

## 5.2 Functional Entities

### 5.2.1 XDM Functional Entities

#### 5.2.1.1 XDMC

The XDMC accesses various XDMS features as described in Section 4. An XDMC implementation may implement various subsets of those features, as required, subject to certain mandatory requirements.

The XDMC can be implemented in both terminal and server entities.

#### 5.2.1.2 Aggregation Proxy

The Aggregation Proxy is the single contact point for Untrusted XDMCs to access XML documents stored in any XDMS. The Aggregation Proxy performs the following functions:

- Performs authentication of an Untrusted XDMC;
- Routes individual XCAP requests to the correct XDMS or to the Cross-Network Proxy;

- Routes individual search requests to the Search Proxy;
- Optionally performs compression/decompression;
- Support secure data transfer between the Aggregation Proxy and the XDMS, using TLS or other means.

### 5.2.1.3 Subscription Proxy

The Subscription Proxy is a server entity that receives subscriptions for notification of changes in XML documents stored in any XDMS. The Subscription Proxy performs the following functions:

- Receives subscriptions for notification of changes in XML documents stored in any XDMS;
- Performs back-end subscriptions as an RLS as described in [RFC4662], according to procedures defined in [RFC5875] for notification of changes in XML documents from a particular XDMS;
- Maps XCAP Resources to SIP addresses of appropriate XDMSs;
- Receives notifications from XDMS, and using RLMI as defined in [RFC4662] aggregates them prior to sending them to the XDMS;
- Sends aggregated notifications to the XDMS.

### 5.2.1.4 Search Proxy

The Search Proxy is a server entity receives search requests. The Search Proxy performs the following functions:

- Forwards search requests to the XDMS, and to the Cross-Network Proxy when appropriate;
- Receives responses from the XDMS, and from the Cross-Network Proxy when appropriate;
- Combines results from the XDMS, and also from the Cross-Network Proxy before sending responses to the XDMS;
- Sends search responses to the XDMS.

### 5.2.1.5 Cross-Network Proxy

The Cross-Network Proxy is the single contact point for the XDM enablers located in different networks to communicate over trusted connection. The Cross-Network Proxy performs the following functions:

- Performs authentication and authorization of the remote network;
- Routes individual outgoing XCAP requests to the Cross-Network Proxy of the remote network;
- Routes individual outgoing search requests to the Cross-Network Proxy of the remote network;
- Routes individual incoming XCAP responses to the Aggregation Proxy;
- Routes individual incoming search responses to the Search proxy;
- Optionally performs compression/decompression;
- Support secure data transfer between Cross-Network Proxies using TLS or other means.

### 5.2.1.6 XDMSs

#### 5.2.1.6.1 Shared List XDMS

The Shared List XDMS is a server entity that supports the following functions:

- Manages and supports content of Shared URI List and Group Usage List XML documents as described in [XDM\_RD];
- Performs authorisation of incoming SIP and XCAP requests;
- Notifies subscribers of changes in XML documents;
- Provides aggregation of notifications of changes to multiple XML documents.

#### **5.2.1.6.2 Shared Group XDMS**

The Shared Group XDMS is a server entity that supports the following functions:

- Manages and supports content of Shared Group XML documents as described in [XDM\_RD];
- Performs authorisation of incoming SIP and XCAP requests;
- Notifies subscribers of changes in XML documents;
- Provides aggregation of notifications of changes to multiple XML documents;
- Provides search results.

#### **5.2.1.6.3 Shared Profile XDMS**

The Shared Profile XDMS is a server entity that supports the following functions:

- Manages and supports content of Shared User Profile XML documents as described in [XDM\_RD];
- Performs authorisation of incoming SIP and XCAP requests;
- Notifies subscribers of changes in XML documents;
- Provides aggregation of notifications of changes to multiple XML documents;
- Provides search results.

#### **5.2.1.6.4 Shared Policy XDMS**

The Shared Policy XDMS is a server entity that supports the following functions:

- Manages and supports content of Shared User Access Policy XML documents as described in [XDM\_RD];
- Performs authorisation of incoming SIP and XCAP requests;
- Notifies subscribers of changes in XML documents;
- Provides aggregation of notifications of changes to multiple XML documents.

#### **5.2.1.6.5 Enabler Specific XDMS**

The Enabler Specific XDMSs are server entities that may support the following functions:

- Performs authorisation of incoming SIP and XCAP requests;
- Manages XML documents, which are specific to the service enabler;
- Provides aggregation of notifications of changes to multiple documents stored on the enabler specific XDMS;
- Notifies subscribers of changes to the enabler specific documents stored in the network;

- Provides search results.

## 5.2.2 External Functional Entities Providing Services to XDM

### 5.2.2.1 SIP/IP Core

The SIP/IP Core is a network of servers, such as proxies and/or registrars, which perform a variety of services in support of the XDM Service, such as routing, authentication, compression, etc. The specific features offered by different types of SIP/IP Core networks will depend on the particulars of those networks.

When the SIP/IP Core is realized using IMS, the OMA XDMSs utilizes the capabilities of IMS as specified in 3GPP [3GPP-TS\_23.228] and 3GPP2 [3GPP2-X.S0013-002], respectively. In such cases the SIP/IP Core performs the following additional functions in support of the XDM Service:

- Routes the SIP messages between any XDMC, Subscription Proxy and the XDMSs;
- Provides discovery and address resolution services;
- Supports SIP compression;
- Performs a certain type of authentication and authorization of the XDMC based on user's service profile;
- Maintains the registration state;
- Provides charging information.

### 5.2.2.2 Device Management Enabler

The Device Management Enabler performs the following functions:

- Initializes and updates the configuration parameters necessary for an XDMC residing in e.g. a UE, by using mechanisms specified in [DM\_Bootstrap] and [DM\_ERELD].

### 5.2.2.3 Charging Enabler

The OMA Charging Enabler [Charging\_AD] coordinates charging data triggers and flow from OMA enablers into an underlying charging infrastructure, supporting on-line and off-line charging. XDM entities that may optionally report Chargeable Events are:

- Aggregation Proxy;
- Subscription Proxy;
- Search Proxy;
- Shared XDMSs (i.e. Shared Profile XDMS, Shared Group XDMS, Shared Policy XDMS, and Shared List XDMS);
- Enabler specific XDMSs.

## 5.3 Description of Reference Points

### 5.3.1 XDM Reference Points

#### 5.3.1.1 Reference Point XDM-1: Untrusted XDMC – SIP/IP Core

The XDM-1 Reference Point supports the communication between the Untrusted XDMC and the SIP/IP Core network. The protocol for the XDM-1 Reference Point is SIP.

The XDM-1 Reference Point provides the following functions:



- Subscription to the modification of any XDM documents;
- Notification of the modification of any XDM documents.

When SIP/IP Core corresponds with 3GPP/3GPP2 IMS, the XDM-1 Reference Point conforms to the Gm Reference Points for XDMCs implemented in a terminal entity as specified in [3GPP-TS\_23.002] [3GPP2-X.S0013-000].

The XDM-1 Reference Point consists of the SIC-1 Interface.

### 5.3.1.2 Reference Point XDM-2: XDMSs – SIP/IP-Core

The XDM-2 Reference Point supports the communication between the XDMSs (i.e. Shared Profile XDMS, Shared Group XDMS, Shared Policy XDMS, Shared List XDMS and Enabler Specific XDMSs) and the SIP/IP Core. The protocol for the XDM-2 Reference Point is SIP.

The XDM-2 Reference Point provides the following functions:

- Subscription to the modification of XML documents handled by a particular Shared XDMS;
- Notification of the modification of XML documents handled by a particular Shared XDMS.

When SIP/IP Core corresponds with 3GPP/3GPP2 IMS, the XDM-2 Reference Point conforms to the ISC Reference Point [3GPP-TS\_23.002] [3GPP2-X.S0013-000].

The XDM-2 Reference Point consists of the XDM-2i Interface.

### 5.3.1.3 Reference Point XDM-3: Untrusted XDMC – Aggregation Proxy

The XDM-3 Reference Point is between the Untrusted XDMC and the Aggregation Proxy. The protocol for the XDM-3 Reference Point is XCAP.

The XDM-3 Reference Point provides the following functions:

- XML document management of XML documents (e.g. create, modify, retrieve, delete) handled by any XDMS;
- Mutual authentication between XDMC and Aggregation Proxy;
- Optional compression.

When the SIP/IP Core network corresponds with 3GPP/3GPP2 IMS, then the XDM-3 Reference Point conforms to the Ut Reference Point [3GPP-TS\_23.002] [3GPP2-X.S0013-000].

The XDM-3 Reference Point consists of the XDM-3i Interface.

### 5.3.1.4 Reference Point XDM-4: Aggregation Proxy – XDMSs

The XDM-4 Reference Point is between the Aggregation Proxy and the XDMSs. The protocol for the XDM-4 Reference Point is XCAP.

The XDM-4 Reference Point provides the following functions:

- XML document management (e.g. create, modify, retrieve, delete) of XML documents handled by a particular Shared XDMS.

The XDM-4 Reference Point consists of the XDM-4i Interface.

### 5.3.1.5 Reference Point XDM-5: Untrusted XDMC – Aggregation Proxy

The XDM-5 Reference Point is between the XDMC and the Aggregation Proxy. The protocol for the XDM-5 Reference Point is Limited XQuery over HTTP.

The XDM-5 Reference Point provides the following functions:

- Searching information from XML documents stored in any XDMS;
- Mutual authentication of search requests between XDMC and Aggregation Proxy;
- Optional compression.

When the SIP/IP Core network corresponds with 3GPP/3GPP2 IMS, then the XDM-5 Reference Point conforms to the Ut Reference Point [3GPP-TS\_23.002] [3GPP2-X.S0013-000].

The XDM-5 Reference Point consists of the XDM-5i Interface.

### **5.3.1.6 Reference Point XDM-6: Aggregation Proxy – Search Proxy**

The XDM-6 Reference Point is between the Aggregation Proxy and the Search Proxy. The protocol for the XDM-6 Reference Point is Limited XQuery over HTTP.

The XDM-6 Reference Point provides the following functions:

- Searching information from XML documents stored in any XDMS.

The XDM-6 Reference Point consists of the XDM-6i Interface.

### **5.3.1.7 Reference Point XDM-7: Search Proxy – XDMSs**

The XDM-7 Reference Point is between the Search Proxy and the XDMSs. The protocol for the XDM-7 Reference Point is Limited XQuery over HTTP.

The XDM-7 Reference Point provides the following functions:

- Searching information from XML documents stored in XDMSs.

The XDM-7 Reference Point consists of the XDM-7i Interface.

### **5.3.1.8 Reference Point XDM-8: Aggregation Proxy – Cross-Network Proxy**

The XDM-8 Reference Point is between the Aggregation Proxy and the Cross-Network Proxy. The protocol for the XDM-8 Reference Point is XCAP.

The XDM-8 Reference Point provides the following functions:

- Forwarding of XML document management requests/responses between the Aggregation Proxy and the Cross-Network Proxy.

The XDM-8 Reference Point consists of the XDM-8.1i and the XDM-8.2i Interfaces.

### **5.3.1.9 Reference Point XDM-9: Search Proxy – Cross-Network Proxy**

The XDM-9 Reference Point is between the Search Proxy and the Cross-Network Proxy. The protocol for the XDM-9 Reference Point is Limited XQuery over HTTP.

The XDM-9 Reference Point provides the following functions:

- Forwarding of search requests/responses between the Search Proxy and the Cross-Network Proxy.

The XDM-9 Reference Point consists of the XDM-9i and the XDM-6i Interfaces.

### **5.3.1.10 Reference Point XDM-10: Subscription Proxy – SIP/IP Core**

The XDM-10 Reference Point supports the communication between the Subscription Proxy and the SIP/IP Core network. The protocol for the XDM-10 Reference Point is SIP.

The XDM-10 Reference Point provides the following functions:

- Subscription to the modification of any XML documents;
- Notification of the modification of any XML documents;
- Back-end subscription to the modification of XML documents handled by a particular XDMS;
- Notification of the modification of XML documents handled by a particular XDMS.

When SIP/IP Core network corresponds with 3GPP IMS or 3GPP2 MMD networks, the XDM-10 Reference Point conforms to the ISC Reference Point as specified in [3GPP-TS\_23.002] [3GPP2-X.S0013-000].

The XDM-10 Reference Point consists of the XDM-10i and the SIC-2 Interfaces.

#### **5.3.1.11 Reference Point XDM-11: Trusted XDMC - Aggregation Proxy**

The XDM-11 Reference Point supports the communication between the Aggregation Proxy and the Trusted XDMC. The protocol for the XDM-11 Reference Point is XCAP.

The XDM-11 Reference Point provides the following functions:

- XML document management (e.g. create, modify, retrieve, delete) of XML documents handled by any XDMS.

The XDM-11 Reference Point consists of the XDM-8.2i Interface.

#### **5.3.1.12 Reference Point XDM-12: Trusted XDMC– SIP/IP Core**

The XDM-12 Reference Point supports the communication between the Trusted XDMC and the SIP/IP Core. The protocol for the XDM-12 Reference Point is SIP.

The XDM-12 Reference Point provides the following functions:

- Subscription to the modification of XML documents handled by a particular XDMS;
- Notification of the modification of XML documents handled by a particular XDMS.

When SIP/IP Core corresponds with 3GPP/3GPP2 IMS, the XDM-11 Reference Point conforms to the ISC Reference Point [3GPP-TS\_23.002] [3GPP2-X.S0013-000].

The XDM-12 Reference Point consists of the SIC-2 Interface.

#### **5.3.1.13 Reference Point XDM-13: Trusted XDMC - Search Proxy**

The XDM-13 Reference Point is between the Trusted XDMC and the Search Proxy. The protocol for the XDM-13 Reference Point is Limited XQuery over HTTP.

The XDM-13 Reference Point provides the following functions:

- Searching information from XML documents stored in any XDMS.

The XDM-13 Reference Point consists of the XDM-6i Interface.

#### **5.3.1.14 Reference Point XDM-14: Trusted XDMC – XDMSs**

The XDM-14 Reference Point is between the Trusted XDMC and the XDMSs. The protocol for the XDM-14 Reference Point is XCAP.

The XDM-14 Reference Point provides the following functions:

- XML document management (e.g. create, modify, retrieve, delete) of XML documents handled by a particular XDMS.

The XDM-14 Reference Point consists of the XDM-4i Interface.

### 5.3.1.15 Reference Point NNI-1: Cross-Network Proxy – Cross-Network Proxy of remote network

The NNI-1 Reference Point supports the communication between XDM enablers in different domains connected via Cross-Network Proxies. The protocols for the NNI-1 Reference Point are XCAP and Limited XQuery over HTTP transported using any secure protocol or connection i.e. TLS.

The NNI-1 Reference Point consists of the XDM-15i and the XDM-16i Interfaces.

## 5.3.2 External Reference Points Providing Services to XDM

### 5.3.2.1 Reference Point IP-1: SIP/IP Core – SIP/IP Core of remote network

The IP-1 Reference Point supports the communication between the SIP/IP Core network and an XDMS in the remote network via the SIP/IP Core of the remote network. The protocol for the IP-1 Reference Point is SIP.

When the SIP/IP Core network corresponds with 3GPP IMS or 3GPP2 MMD networks, the IP-1 Reference Point conforms to the Ici Reference Point as specified in [3GPP-TS\_23.002] [3GPP2-X.S0013-000].

The IP-1 Reference Point consists of the SIC-3 Interface.

## 5.4 Description of Interfaces

### 5.4.1 XDM Interfaces

#### 5.4.1.1 Interface XDM-2i: XDMSs

The XDM-2i Interface is exposed by the XDMSs. The protocol for the XDM-2i Interface is SIP.

The XDM-2i Interface provides the following functions:

- Subscription to the modification of XML documents handled by a particular XDMS;
- Notification of the modification of XML documents handled by a particular XDMS.

#### 5.4.1.2 Interface XDM-3i: Aggregation Proxy

The XDM-3i Interface is exposed by the Aggregation Proxy. The protocol for the XDM-3i Interface is XCAP.

The XDM-3i Interface provides the following functions:

- Forwarding of requests to the Aggregation Proxy for XML document management of XML documents (e.g. create, modify, retrieve, delete) handled by any XDMS;
- Receiving responses from the Aggregation Proxy for XML document management of XML documents (e.g. create, modify, retrieve, delete) handled by any XDMS;
- Mutual authentication between XDMS and Aggregation Proxy;
- Optional compression.

#### 5.4.1.3 Interface XDM-4i: XDMSs

The XDM-4i Interface is exposed by the XDMSs. The protocol for the XDM-4i Interface is XCAP.

The XDM-4i Interface provides the following functions:

- Forwarding of request to a particular for XML document management (e.g. create, modify, retrieve, delete) of XML documents handled by a particular XDMS;

- Receiving responses from the particular XDMS for XML document management (e.g. create, modify, retrieve, delete) of XML document handled by the particular XDMS.

#### 5.4.1.4 Interface XDM-5i: Aggregation Proxy

The XDM-5i Interface is exposed by the Aggregation Proxy. The protocol for the XDM-5i Interface is Limited XQuery over HTTP.

The XDM-5 Interface provides the following functions:

- Forwarding of search requests to the Aggregation Proxy for searching information from XML documents stored in any XDMS;
- Receiving search responses from the Aggregation Proxy for the search requests;
- Mutual authentication of search requests between XDMS and Aggregation Proxy;
- Optional compression.

#### 5.4.1.5 Interface XDM-6i: Search Proxy

The XDM-6i Interface is exposed by the Search Proxy. The protocol for the XDM-6i Interface is Limited XQuery over HTTP.

The XDM-6 Interface provides the following functions:

- Forwarding of search requests to the Search Proxy for searching information from XML documents stored in any XDMS;
- Receiving search responses from the Search Proxy for the search requests.

#### 5.4.1.6 Interface XDM-7i: XDMSs

The XDM-7i Interfaces is exposed by the XDMSs. The protocol for the XDM-7i Interface is Limited XQuery over HTTP.

The XDM-7i Interface provides the following functions:

- Forwarding of search requests for searching information from XML documents stored in a particular XDMS;
- Receiving search responses from the particular XDMS for the search request.

#### 5.4.1.7 Interface XDM-8.1i: Cross-Network Proxy

The XDM-8.1i Interface is exposed by the Cross-Network Proxy. The protocol for the XDM-8.1i Interface is XCAP.

The XDM-8.1i Interface provides the following functions:

- Forwarding of requests to the Cross-Network Proxy for XML document management of XML documents (e.g. create, modify, retrieve, delete) handled by any XDMS in remote networks;
- Receiving responses from the Cross-Network Proxy for XML document management of XML documents (e.g. create, modify, retrieve, delete) handled by any XDMS in remote networks.

#### 5.4.1.8 Interface XDM-8.2i: Aggregation Proxy

The XDM-8.2i Interface is exposed by the Aggregation Proxy. The protocol for the XDM-8.2i Interface is XCAP.

The XDM-8.2i Interface provides the following functions:

- Forwarding of requests to the Aggregation Proxy for XML document management of XML documents (e.g. create, modify, retrieve, delete) handled by any XDMS;

- Receiving responses from the Aggregation Proxy for XML document management of XML documents (e.g. create, modify, retrieve, delete) handled by any XDMS.

#### 5.4.1.9 Interface XDM-9i: Cross-Network Proxy

The XDM-9i Interface is exposed by the Cross-Network Proxy. The protocol for the XDM-9i Interface is Limited XQuery over HTTP.

The XDM-9i Interface provides the following functions:

- Forwarding of search requests to the Cross-Network Proxy for searches in remote domains;
- Receiving search responses from the Cross-Network Proxy for searches in remote domains.

#### 5.4.1.10 Interface XDM-10i: Subscription Proxy

The XDM-10i Interface is exposed by the Subscription Proxy. The protocol for the XDM-10i Interface is SIP.

The XDM-10i Interface provides the following functions:

- Subscription to modifications of any XML documents;
- Notification of modifications of any XML documents.

#### 5.4.1.11 Interface XDM-15i: Cross-Network Proxy

The XDM-15i Interface is exposed by the Cross-Network Proxy. The protocols for the XDM-15i Interface is XCAP transported using any secure protocol or connection e.g. TLS between remote networks.

The XDM-15i Interface provides the following functions:

- Forwarding of requests to the Cross-Network Proxy for XML document management of XML documents (e.g. create, modify, retrieve, delete) handled by any XDMS residing in the same domain as the Cross-Network Proxy;
- Receiving responses from the Cross-Network Proxies for XML document management of XML documents (e.g. create, modify, retrieve, delete) handled by any XDMS residing in the same domain as the Cross-Network Proxy.

#### 5.4.1.12 Interface XDM-16i: Cross-Network Proxy

The XDM-16i Interface is exposed by the Cross-Network Proxy. The protocols for the XDM-16i Interface is Limited XQuery over HTTP transported using any secure protocol or connection e.g. TLS between remote networks.

The XDM-16i Interface provides the following functions:

- Forwarding of search requests to the Cross-Network Proxy for searching information from XML documents stored in any XDMS residing in the same domain as the Cross-Network Proxy;
- Receiving search responses from the Cross-Network Proxy for the search requests.

### 5.4.2 External Interfaces used by the XDM enabler

#### 5.4.2.1 Interface SIC-1: SIP/IP Core

The SIC-1 Interface is exposed by the SIP/IP Core network and reused by the XDM enabler. The protocol for the SIC-1 Interface is SIP.

The SIC-1 Interface provides the following functions:

- Authentication;

- Subscription to the modification of any XDM documents;
- Notification of the modification of any XDM documents.

When the SIP/IP Core network corresponds with 3GPP IMS or 3GPP2 MMD networks, the SIC-1 Interface conforms to the interface that the Gm Reference Point is accessed through as specified in [3GPP-TS\_23.002] [3GPP2-X.S0013-000].

#### **5.4.2.2 Interface SIC-2: SIP/IP Core**

The SIC-2 Interface is exposed by the SIP/IP Core network and reused by the XDM enabler. The protocol for the SIC-2 Interface is SIP.

The SIC-2 Interface provides the following functions:

- Subscription to the modification of any XDM documents;
- Notification of the modification of any XDM documents.

When the SIP/IP Core network corresponds with 3GPP IMS or 3GPP2 MMD networks, the SIC-2 Interface conforms to the interface that the ISC Reference Point is accessed through as specified in [3GPP-TS\_23.002] [3GPP2-X.S0013-000].

#### **5.4.2.3 Interface SIC-3: SIP/IP Core**

The SIC-3 Interface is exposed by the SIP/IP Core and reused by the XDM enabler. The protocol for the SIC-3 Interface is SIP.

- The SIC-3i Interface supports the communication between SIP/IP Core networks.

When the SIP/IP Core network corresponds with 3GPP IMS or 3GPP2 MMD networks, the SIC-3 Interface conforms to the interface that the Ici Reference Point is accessed through as specified in [3GPP-TS\_23.002] [3GPP2-X.S0013-000].

#### **5.4.2.4 Interfaces CH-1/CH-2: Charging Enabler**

The CH-1 and CH-2 Interfaces are described in [Charging\_AD].

Implementations of XDM components may act as Charging Enabler users [Charging\_AD]. Figure 3 shows the interfaces between these entities and the charging enabler. Two Interfaces are currently supported by the Charging Enabler, CH-1 for offline charging and CH-2 for on line charging. These are described in [Charging\_AD].

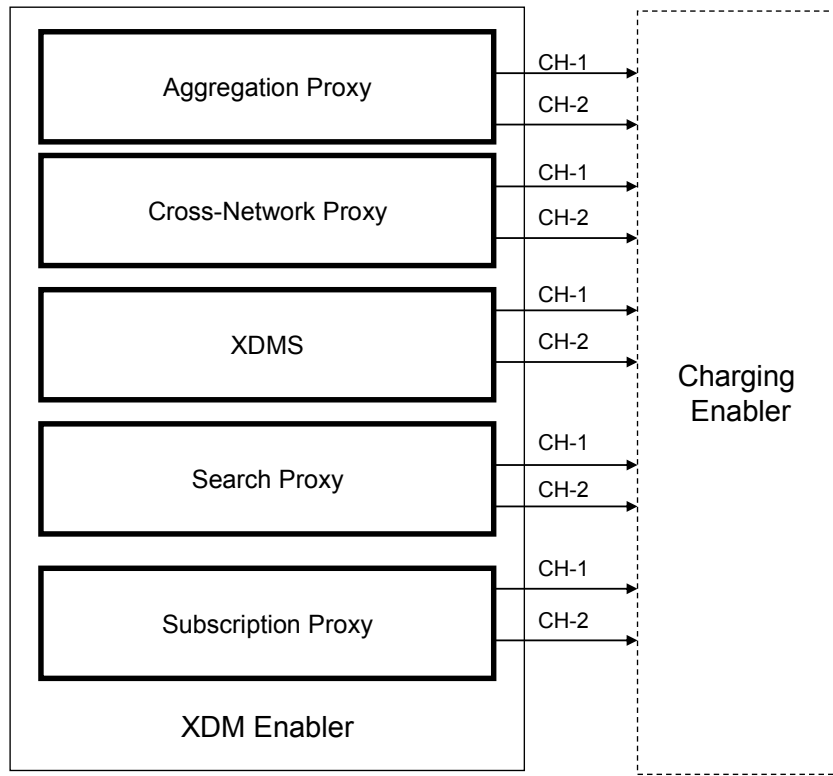

Dashed Boxes and Interfaces are not specified by XDM enabler

**Figure 3: XDM Enabler Use of the Charging Enabler’s CH-1 and CH-2 Interfaces**



## 6. Backward compatibility towards the XDM Enabler version 1.1 and the PoC Enabler version 1.0.

The following deployment scenarios are supported for the purpose of backward compatibility:

Scenario A) where:

- The XDM Enabler version 1.1 [XDM\_ERELD-V1\_1] is replaced with the XDM Enabler version 2.0 [XDM\_ERELD-V2\_0]. The PoC Enabler version 1.0 [PoC\_ERELD-V1\_0] is replaced with the PoC Enabler version 2.0 [PoC\_ERELD-V2\_0]. The PoC Enabler version 2.0 shares Group and User Access Policy documents in Shared Group XDMS and Shared Policy XDMS, with other enablers (e.g., SIMPLE IM Enabler version 1.0 [IM\_ERELD-V1\_0]);
- The XDM version 1.1 clients implemented in a PoC version 1.0 compliant UE are supported for the purpose of backward compatibility;
- The XDM version 1.1 clients implemented in a PoC version 1.0 compliant PoC Application Server are not supported, as the PoC Enabler is upgraded to version 2.0;
- The XDM version 2.0 clients implemented in a PoC version 2.0 compliant UE are supported;
- The XDM version 2.0 clients implemented in a PoC version 2.0 compliant PoC Application Server are supported.

In order to support the above Scenario A),

- The Aggregation Proxy supports also via the Reference Point XDM-4 the Reference Point PoC-7 [PoC\_AD-V1\_0] to route the PoC group or PoC user access policy document requests to Shared Group XDMS or Shared Policy XDMS respectively;
- The Shared Group XDMS supports also via the Reference Point XDM-2 the Reference Point PoC-6 [PoC\_AD-V1\_0] to process the PoC group documents SIP requests and to generate corresponding responses and to generate SIP requests and to process corresponding responses as if it is PoC XDMS [PoC\_AD-V1\_0];
- The Shared Group XDMS supports also via the Reference Point XDM-4 the Reference Point PoC-7 [PoC\_AD-V1\_0] to process the PoC group documents requests and to generate corresponding responses as if it is PoC XDMS [PoC\_AD-V1\_0];
- The Shared Policy XDMS supports also via the Reference Point XDM-2 the Reference Point PoC-6 [PoC\_AD-V1\_0] to process the PoC user access policy document SIP requests and to generate corresponding responses and to generate SIP requests and to process corresponding responses as if it is PoC XDMS [PoC\_AD-V1\_0];
- The Shared Policy XDMS supports also via the Reference Point XDM-4 the Reference Point PoC-7 [PoC\_AD-V1\_0] to process the PoC user access policy document requests and to generate corresponding responses as if it is PoC XDMS [PoC\_AD-V1\_0];
- The XDM version 1.0 clients implemented in a PoC version 1.0 compliant UE are able to make requests through the Reference Point XDM-3 to access the PoC group or PoC user access policy documents in Shared Group XDMS or Shared Policy XDMS, as if they reside in PoC XDMS.

Scenario B) are where:

- The XDM Enabler version 1.1 [XDM\_ERELD-V1\_1] is replaced with the XDM Enabler version 2.0 [XDM\_ERELD-V2\_0] due to other enablers (e.g., SIMPLE IM version 1.0 [IM\_ERELD-V1\_0]) than PoC Enabler version 1.0 [PoC\_ERELD-V1\_0]. However, the PoC Enabler version 1.0 remains as it is. The PoC Enabler version 1.0 does not share PoC group or PoC user access policy documents with other enablers, but keep those in PoC XDMS [PoC\_AD-V1\_0];
- The XDM version 1.1 clients implemented in a PoC version 1.0 compliant UE are supported for the purpose of backward compatibility;

- XDM version 1.1 clients implemented in a PoC version 1.0 compliant PoC Application Server are supported for the purpose of backward compatibility;
- The XDM version 2.0 clients implemented in a PoC version 2.0 compliant UE are supported.;
- XDM version 2.0 clients implemented in a PoC version 2.0 compliant PoC Application Server are not supported as the PoC Enabler remain as version 1.0.

In order to support the above Scenario B),

- The Aggregation Proxy supports also via the Reference Point XDM-4 the Reference Point PoC-7 [PoC\_AD-V1\_0] to route the PoC group or PoC user access policy documents requests to PoC XDMS;
- The XDM version 2.0 clients implemented in a PoC version 2.0 compliant UE are able to use their embedded PoC version 1.0 functions to make requests through the Reference Point XDM-3 to access the PoC group or PoC user access policy documents in PoC XDMS.

## Appendix A. Change History

(Informative)

### A.1 Approved Version 2.0 History

Reference	Date	Description
OMA-AD-XDM-V2_0-20120403-A	03 Apr 2012	Status changed to Approved by TP: OMA-TP-2012-0135-INP_XDM_V2_0_ERP_for_Final_Approval

## Appendix B. How to show re-use of the XDM Enabler (Informative)

This section describes how OMA Enabler can re-use the XDM Enabler and shows how this should be reflected in the Enabler's architecture diagrams.

To make the architecture diagrams of Enablers re-using XDM Enabler simpler, the architecture diagrams should show only how the Enabler is using the different XDMSs, XDM interfaces (or reference points) and not the entire XDM architecture model. The architecture document is recommended to include the following information:

- A figure as shown below as part of the “Architectural Diagram” section. It is recommended
  - to show which Enabler specific entities that are using the XDM Enabler;
  - to show which XDMSs and application usages that the enabler is using;
  - to show which of XDM/SIC Interfaces the Enabler specific entities are using;
  - to show an Enabler Specific Entity with an embedded Untrusted XDMC or Trusted XDMC, when the functions of an Untrusted XDMC, respectively Trusted XDMC defined in the XDM Enabler cover the needs of the reusing Enabler.
    - If the Enabler simply uses the Untrusted XDMC, or respectively the Trusted XDMC, for operations on various application usages (Enabler specific or generic XDM defined application usages) the XDM/SIC interfaces (or reference points) should be shown in the AD diagram.
    - If the Enabler needs go beyond XDM support, then the Enabler should define and label its own Enabler specific interfaces;
  - not to show in the “main” Enabler architectural diagram how the XDM Enabler is used.
- In the section “Functional Entities” it is recommended that per Entity using the XDM enabler it is listed which particular XDMSs this entity is using;
- In the section “Functional Entities” it is recommended that per Enabler Specific XDMS it is listed which XDM functions in the list in section 5.2.1.6.5 it supports;
- The XDM Interfaces in the diagram are recommended to be described under a Sub section “External Interfaces” under the “Interfaces” Section in the architecture document. The description is recommended only to contain a text that contains a reference to the XDM-AD e.g. “The XDM-8.2i Interface is described in [XDM\_AD]”.

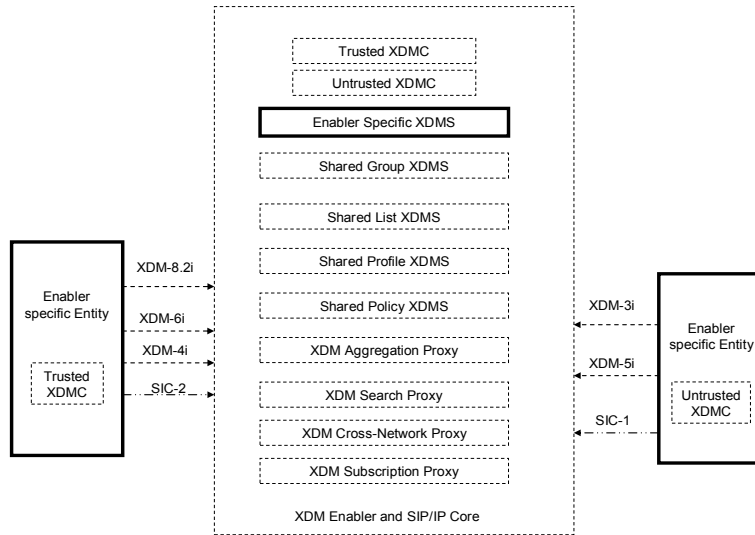

Dashed Boxes and Interfaces are described in [XDM\_AD]

**Figure 4: Complete XDM architecture that can be reused by an Enabler**

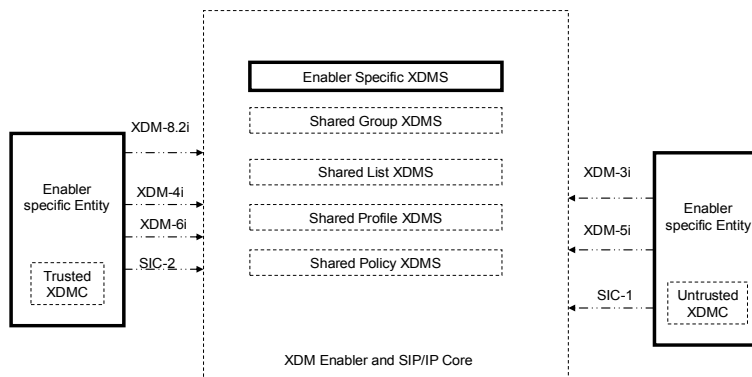

- Dashed Boxes and Interfaces are described in [XDM\_AD]
- Solid boxes are defined by the Enabler

**Figure 5: How an Enabler should depict reuse of the XDM enabler.**

Solid lines show the Enabler specific entities and dotted line is used for XDM entities and interfaces. The Enabler reusing XDM should show only the XDMSs used and the XDMC entities.

For reuse of XDM with reference points, the same recommendation and representation convention applies.