



XML Document Management Architecture

Candidate Version 2.1 – 23 Oct 2009

Open Mobile Alliance
OMA-AD-XDM-V2_1-20091023-C

Use of this document is subject to all of the terms and conditions of the Use Agreement located at <http://www.openmobilealliance.org/UseAgreement.html>.

Unless this document is clearly designated as an approved specification, this document is a work in process, is not an approved Open Mobile Alliance™ specification, and is subject to revision or removal without notice.

You may use this document or any part of the document for internal or educational purposes only, provided you do not modify, edit or take out of context the information in this document in any manner. Information contained in this document may be used, at your sole risk, for any purposes. You may not use this document in any other manner without the prior written permission of the Open Mobile Alliance. The Open Mobile Alliance authorizes you to copy this document, provided that you retain all copyright and other proprietary notices contained in the original materials on any copies of the materials and that you comply strictly with these terms. This copyright permission does not constitute an endorsement of the products or services. The Open Mobile Alliance assumes no responsibility for errors or omissions in this document.

Each Open Mobile Alliance member has agreed to use reasonable endeavors to inform the Open Mobile Alliance in a timely manner of Essential IPR as it becomes aware that the Essential IPR is related to the prepared or published specification. However, the members do not have an obligation to conduct IPR searches. The declared Essential IPR is publicly available to members and non-members of the Open Mobile Alliance and may be found on the “OMA IPR Declarations” list at <http://www.openmobilealliance.org/ipr.html>. The Open Mobile Alliance has not conducted an independent IPR review of this document and the information contained herein, and makes no representations or warranties regarding third party IPR, including without limitation patents, copyrights or trade secret rights. This document may contain inventions for which you must obtain licenses from third parties before making, using or selling the inventions. Defined terms above are set forth in the schedule to the Open Mobile Alliance Application Form.

NO REPRESENTATIONS OR WARRANTIES (WHETHER EXPRESS OR IMPLIED) ARE MADE BY THE OPEN MOBILE ALLIANCE OR ANY OPEN MOBILE ALLIANCE MEMBER OR ITS AFFILIATES REGARDING ANY OF THE IPR'S REPRESENTED ON THE “OMA IPR DECLARATIONS” LIST, INCLUDING, BUT NOT LIMITED TO THE ACCURACY, COMPLETENESS, VALIDITY OR RELEVANCE OF THE INFORMATION OR WHETHER OR NOT SUCH RIGHTS ARE ESSENTIAL OR NON-ESSENTIAL.

THE OPEN MOBILE ALLIANCE IS NOT LIABLE FOR AND HEREBY DISCLAIMS ANY DIRECT, INDIRECT, PUNITIVE, SPECIAL, INCIDENTAL, CONSEQUENTIAL, OR EXEMPLARY DAMAGES ARISING OUT OF OR IN CONNECTION WITH THE USE OF DOCUMENTS AND THE INFORMATION CONTAINED IN THE DOCUMENTS.

© 2009 Open Mobile Alliance Ltd. All Rights Reserved.

Used with the permission of the Open Mobile Alliance Ltd. under the terms set forth above.

Contents

- 1. SCOPE (INFORMATIVE)4
- 2. REFERENCES5
 - 2.1 NORMATIVE REFERENCES5
 - 2.2 INFORMATIVE REFERENCES6
- 3. TERMINOLOGY AND CONVENTIONS7
 - 3.1 CONVENTIONS7
 - 3.2 DEFINITIONS7
 - 3.3 ABBREVIATIONS8
- 4. INTRODUCTION (INFORMATIVE).....10
 - 4.1 VERSION 1.110
 - 4.2 VERSION 2.010
 - 4.2.1 Version 2.110
- 5. ARCHITECTURAL MODEL12
 - 5.1 DEPENDENCIES12
 - 5.2 ARCHITECTURAL DIAGRAM12
 - 5.3 FUNCTIONAL COMPONENTS AND INTERFACES/REFERENCE POINTS DEFINITION.....13
 - 5.3.1 XDM Functional Entities13
 - 5.3.2 External Functional Entities Providing Services to XDM19
 - 5.3.3 Description of XDM Reference Points19
 - 5.3.4 External Reference Points Providing Services to XDM24
 - 5.4 DESCRIPTION OF INTERFACES24
 - 5.4.1 XDM Interfaces24
 - 5.4.2 External Interfaces used by the XDM Enabler.....27
 - 5.5 SECURITY CONSIDERATIONS28
- 6. BACKWARD COMPATIBILITY29
 - 6.1 BACKWARD COMPATIBILITY TOWARDS THE XDM 2.0 VERSION.....29
 - 6.2 BACKWARD COMPATIBILITY TOWARDS THE XDM ENABLER VERSION 1.1 AND THE PoC ENABLER VERSION 1.0.
29
- APPENDIX A. CHANGE HISTORY (INFORMATIVE).....32
 - A.1 APPROVED VERSION HISTORY32
 - A.2 DRAFT/CANDIDATE VERSION 2.1 HISTORY32
- APPENDIX B. HOW TO SHOW RE-USE OF THE XDM ENABLER (INFORMATIVE)34
- APPENDIX C. XDM SERVICE PROVISIONING35
- APPENDIX D. USE OF CHARGING ENABLER FOR XDM CHARGING (INFORMATIVE).....36

Figures

- Figure 1: XDM Architecture using Reference Points12
- Figure 2: XDM Architecture using Interfaces13
- Figure 3: How to show reuse of the XDM Enabler.....34
- Figure 4: XDM Enabler Use of the Charging Enabler’s CH-1 and CH-2 Interfaces36

1. Scope

(Informative)

This document presents an overview of the XML Document Management (XDM) enabler release 2.1. Specifically, it serves as an introduction to the functionality and architecture of the XDM enabler.

2. References

2.1 Normative References

OMA

- [Charging_AD] “Charging Architecture”, Version 1.0, Open Mobile Alliance™, OMA-AD-Charging-V1_0, URL: <http://www.openmobilealliance.org/>
- [Dict] “Dictionary for OMA Specifications”, Version 2.7, Open Mobile Alliance™, OMA-ORG-Dictionary-V2_7, URL: <http://www.openmobilealliance.org/>
- [DM_ERELD] “Enabler Release Definition for OMA Device Management”, Version 1.2, Open Mobile Alliance™, OMA-ERELED-DM-V1_2, URL: <http://www.openmobilealliance.org/>
- [DM_SO] “OMA Device Management Standardized Objects”, Version 1.2, Open Mobile Alliance™, OMA-TS-DM-StdObj-V1_2, URL: <http://www.openmobilealliance.org/>
- [IM_ERELD-V1_0] “Enabler Release Definition for SIMPLE IM”, Draft Version 1.0, Open Mobile Alliance™, OMA-ERELED-SIMPLE_IM-V1_0, URL: <http://www.openmobilealliance.org/>
- [OSE_AD_V1_0] “OMA Service Environment”, Version 1.0, Open Mobile Alliance™, OMA-AD-Service-Environment-V1_0, URL: <http://www.openmobilealliance.org/>
- [PoC_AD-V1_0] “Push to talk over Cellular (PoC) – Architecture”, Version 1.0, Open Mobile Alliance™, OMA-AD-PoC-V1_0, URL: <http://www.openmobilealliance.org/>
- [PoC_ERELD-V1_0] “Enabler Release Definition for Push-to-Talk over Cellular”, Version 1.0, Open Mobile Alliance™, OMA-ERELED-POC-V2_0, URL: <http://www.openmobilealliance.org/>
- [PoC_ERELD-V2_0] “Enabler Release Definition for Push-to-Talk over Cellular”, Draft Version 2.0, Open Mobile Alliance™, OMA-ERELED-POC-V2_0, URL: <http://www.openmobilealliance.org/>
- [Push_AD-V2_2] “Push Architecture” Version 2.2, Open Mobile Alliance™, OMA-AD-Push-V2_2, URL: <http://www.openmobilealliance.org/>
- [SEC_CF-V1_0] “Security Common Functions Architecture”, Version 1.0, Open Mobile Alliance™, OMA-ERELED-SEC_CF-V1_0, URL: <http://www.openmobilealliance.org/>
- [XDM_ERELD-V1_1] “Enabler Release Definition for XML Document Management”, Version 1.1, Open Mobile Alliance™, OMA-ERELED-XDM-V1_1, URL: <http://www.openmobilealliance.org/>
- [XDM_ERELD-V2_0] “Enabler Release Definition for XML Document Management”, Version 2.0, Open Mobile Alliance™, OMA-ERELED-XDM-V2_0, URL: <http://www.openmobilealliance.org/>
- [XDM_RD] “XML Document Management Requirements”, Version 2.1, Open Mobile Alliance™, OMA-RD-XDM-V2_1, URL: <http://www.openmobilealliance.org/>

IETF

- [IETF-XCAP_Diff_Event] IETF draft-ietf-sip-xcapevent-03 “An Extensible Markup Language (XML) Configuration Access Protocol (XCAP) Diff Event Package”, J. Urpalainen, May 2008, URL: <http://www.ietf.org/internet-drafts/draft-ietf-sip-xcapevent-03.txt>

Note: Work in progress

- [RFC2119] IETF RFC 2119 “Key words for use in RFCs to Indicate Requirement Levels”, S. Bradner, March 1997,
URL: <http://www.ietf.org/rfc/rfc2119.txt>
- [RFC4662] IETF RFC 4662 “A Session Initiation Protocol (SIP) Event Notification Extension for Resource Lists”, A.
B. Roach, B. Campbell, J. Rosenberg, August 2006,
URL: <http://www.ietf.org/rfc/rfc4662.txt>
- 3GPP**
- [3GPP2-X.S0013-000] 3GPP2 X.S0013-000 “All-IP Core Network Multimedia Domain: Overview”,
URL: http://www.3gpp2.org/Public_html/specs/index.cfm
- [3GPP2-X.S0013-002] 3GPP2 X.S0013-002 “All-IP Core Network Multimedia Domain: IP Multimedia Subsystem - Stage 2”,
URL: http://www.3gpp2.org/Public_html/specs/index.cfm
- [3GPP-TS_23.002] 3GPP TS 23.002 “Network architecture”,
URL: http://www.3gpp.org/ftp/Specs/archive/23_series/23.002/
- [3GPP-TS_23.228] 3GPP TS 23.228 “IP Multimedia Subsystem (IMS); Stage 2”,
URL: http://www.3gpp.org/ftp/Specs/archive/23_series/23.228/

2.2 Informative References

OMA

- [PoC_XDM] "OMA PoC Document Management", Version 1.0, Open Mobile Alliance™,
OMA-TS-PoC_Document_Management-V1_0,
URL: <http://www.openmobilealliance.org/>

IETF

- [RFC3324] IETF RFC 3324 “Short Term Requirements for Network Asserted Identity”, M. Watson, November 2002,
URL: <http://www.ietf.org/rfc/rfc3324.txt>
- [RFC4825] IETF RFC 4825 “The Extensible Markup Language (XML) Configuration Access protocol (XCAP)”, J.
Rosenberg, May 2007,
URL: <http://www.ietf.org/rfc/rfc4825.txt>

3GPP

- [3GPP-TS_33.222] 3GPP TS 33.222 “Generic Authentication Architecture (GAA); Access to network application functions
using Hypertext Transfer Protocol over Transport Layer Security (HTTPS)”,
URL: http://www.3gpp.org/ftp/Specs/archive/33_series/33.222/

Others

- [W3C-XQUERY] W3C Recommendation “XQuery 1.0: An XML Query Language”, Scott Boag et al., Jan 2007, World
Wide Web Consortium (W3C),
URL: <http://www.w3.org/TR/xquery>

3. Terminology and Conventions

3.1 Conventions

The key words “MUST”, “MUST NOT”, “REQUIRED”, “SHALL”, “SHALL NOT”, “SHOULD”, “SHOULD NOT”, “RECOMMENDED”, “MAY”, and “OPTIONAL” in this document are to be interpreted as described in [RFC2119].

All sections and appendixes, except “Scope” and “Introduction”, are normative, unless they are explicitly indicated to be informative.

3.2 Definitions

Access Permissions	Use definition from [XDM_RD].
Access Permissions List	A list of XDM resources that the Primary Principal has permission to access.
Alias Principal	Use definition from [XDM_RD].
Chargeable Event	Use definition from [Dict].
Document Share by Reference	A function to share all content in two documents by using one document as the master document and in the other document only having a reference to that master document.
Client	Use definition from [Dict].
Enabler	Use definition from [Dict].
Enabler Release	Use definition from [Dict].
Extended Group Advertisements	A function to inform group members about e.g. membership in a Group as described in [XDM_RD] section “ <i>Extended Group Advertisements</i> ”.
Forward List	A document used to store the information related to the XDM Resources received through XDCCP requests from other users which is meant for forwarding XDM Resources.
Group	Use definition from [XDM_RD].
Group Usage List	Use definition from [XDM_RD].
History Information	The information containing the details of XDM Operations performed on a particular XDM Document.
I2 Interface	Use definition from [[OSE_AD_V1_0] section “ <i>Interfaces of the OSE</i> ”.
Interface	The common boundary between two associated systems. (Source: [Dict])
Limited XQuery over HTTP	The subset of XQuery functions that are used in OMA XDM Search requests.
Management Object	Use definition from [DM_SO] section “ <i>Standardized Objects</i> ”.
Primary Principal	Use definition from [XDM_RD].
Principal	Use definition from [Dict].
Push Enabled Application	Use definition from [Push_AD-V2_2]
Push Initiator	Use definition from [Push_AD-V2_2]
Push Messages	Use definition from [Push_AD-V2_2]
Reference Point	Use definition from [Dict].
Remote Network	A network where a requesting Principal is not a Subscriber.
Resource List Meta-Information	A document describing the state of virtual subscriptions associated with a list subscription. (Source: [RFC4662])
Resource List Server	RLSes accept subscriptions to resource lists and send notifications to update subscribers of the state of the resources in a resource list. (Source: [RFC4662])
Subscriber	Use definition from [Dict].

UPP Directory	A UPP Directory as described in [XDM_RD] section “ <i>UPP Directory</i> ”.
URI List	Use definition from [XDM_RD].
User Access Policy	A User Access Policy as described in [XDM_RD] section “ <i>User Access Policy</i> ”.
User Profile	Use definition from [XDM_RD].
XDM Differential	A format that conveys changes to an XDM Document.
XDMSs	A logical entity to group XDMSs defined by the XDM Enabler.
XDM Document	Use definition from [XDM_RD].
XDM Document Part	Use definition from [XDM_RD].
XDM Resource	Use definition from [XDM_RD].
XDM Search	A Limited XQuery over HTTP protocol used to search the XML Resource located in any XDMS.
XML Document Command Protocol	An HTTP based protocol used to issue commands related to XDM Resource processing, which does not include XCAP and XDM Search.

3.3 Abbreviations

CPM	Converged IP Messaging
DM	Device Management
GAA	Generic Authentication Architecture
HTTP	Hyper Text Transfer Protocol
IETF	Internet Engineering Task Force
IM	Instant Messaging
IP	Internet Protocol
OMA	Open Mobile Alliance
PoC	Push to talk over Cellular
RLMI	Resource List Meta-Information
RLS	Resource List Server
SIC	SIP/IP Core
SIMPLE	SIP for Instant Messaging and Presence Leveraging Extension
SIP	Session Initiation Protocol
TLS	Transport Layer Security
UE	User Equipment
UPP	User Preferences Profile
XCAP	XML Configuration Access Protocol
XDCP	XML Document Command Protocol
XDM	XML Document Management
XDMC	XML Document Management Client
XDMS	XML Document Management Server

XML Extensible Markup Language

XQuery XML Query

4. Introduction

(Informative)

Architecture Document describes the features and architecture of the OMA XDM enabler.

4.1 Version 1.1

The XDM Enabler defines a common mechanism that makes user-specific service-related information accessible to the Enablers that need it. XDM specifies how such information is represented in well-structured XML documents, as well as the common protocol for access and manipulation (e.g. create, modify, delete, etc.) of such XML documents.

The XDM Specification [XDM_Core] defines the features of the XDM Enabler, which include the following:

- The common protocol, XCAP [RFC4825], by which Principals can store and manipulate their service-related data, stored in a network as XML documents.

Documents accessed and manipulated via XCAP are stored in logical repositories in the network, called XDMSs. Each repository may be associated with a functional entity which uses its data to perform its functions.

Each XML document stored in an XDMS is described as an Application Usage, which enables applications to use the document via XCAP. The XDM Enabler describes Application Usages which can be reused by multiple Enablers and are stored in logical entities called Shared XDMSs. The documents defined by the XDM V1.1 Enabler are as follows:

- URI List and Group Usage List documents stored in the Shared XDMS.

4.2 Version 2.0

The XDM V2.0 Enabler defines new functionalities that extend XDM to support the OMA SIMPLE IM V1.0 and PoC V2.0 Enablers.

To accommodate the needs of these Enablers, the following functionalities are added in XDM V2.0:

- Search for information in XDM Documents stored in an XDMS;
- Network to Network Interface to enable search and retrieval of information across multiple domains; and
- The SIP subscription/notification mechanism by which Principals can be notified of changes to XDM Documents or XDM Document Parts.

XDM V2.0 inherits the Shared XDMS from XDM V1.0, but renames it as the Shared List XDMS to accommodate several new documents that are stored in separate Shared XDMS logical entities:

- Group XDM Document stored in the Shared Group XDMS;
- User Access Policy XDM Document stored in the Shared Policy XDMS; and
- User Profile XDM Document stored in the Shared Profile XDMS.

The Group and User Access Policy XDM Document structures are based on those of the PoC Group and PoC User Access Policy XDM Documents [PoC_XDM], respectively. The XDM V2.0 Enabler defines how to handle backwards compatibility with the PoC V1.0 Enabler when the Shared Group XDMS and Shared Policy XDMS are introduced in the network.

4.2.1 Version 2.1

The XDM V2.1 Enabler defines new functionalities that extend XDM. Among those functionalities some are related to the requirements derived from other OMA Enablers (i.e. OMA CPM 1.0, OMA CAB 1.0 and OMA POC 2.1).

The following functionalities are added in XDM V2.1:

- Access Permissions to define which Principals have rights to perform XDM functions to an XDM Resource;

- Notifying Principals when their Access Permissions to a specific XDM Resource are changed;
- Document history management in order to capture some (or all) changes applied to an XDM Document;
- Restore operation which enables the authorized Principals to restore the XDM Documents to one of its previous versions;
- Forwarding of an XDM Document or XDM Document Parts by a Principal with appropriate permissions to other Principals;
- User Preferences Profiles which controls aspects of how a user perceives and receives services;
- Support for searching for active sessions;
- Document Share by Reference which enables authorized Principals to share the contents of an XDM document with other Principals;
- An alternative mechanism to SIP to perform subscription to XDM Resource changes and receive notifications indicating XDM Resource creations, modifications and removals;
- Extensions to User Access Policy and Group XDM Documents; and
- XDM Differential write request to modify XDM Document Parts with a single modify request, and XDM Differential read request to retrieve XDM Document Parts by obtaining the changes to the XDM Document, as opposed to obtaining the entire XDM Document

All “Shared xyz XDMS”s defined by the XDM Enabler are renamed to “xyz XDMS”.

NOTE: XDM V2.1 inherits the Shared List XDMS, Shared Group XDMS, Shared Profile XDMS and Shared Policy XDMS from XDM V2.0, but renames them as the List XDMS, Group XDMS, Profile XDMS and Policy XDMS.

5. Architectural Model

The XDM Enabler defines a common mechanism that makes user-specific service-related information accessible to Enablers that need it.

The architecture model is based on the requirements defined in [XDM_RD].

5.1 Dependencies

The XDM Enabler depends on the following external functional entities:

- SIP/IP Core and;
- Device Management Enabler [DM_ERELD].

5.2 Architectural Diagram

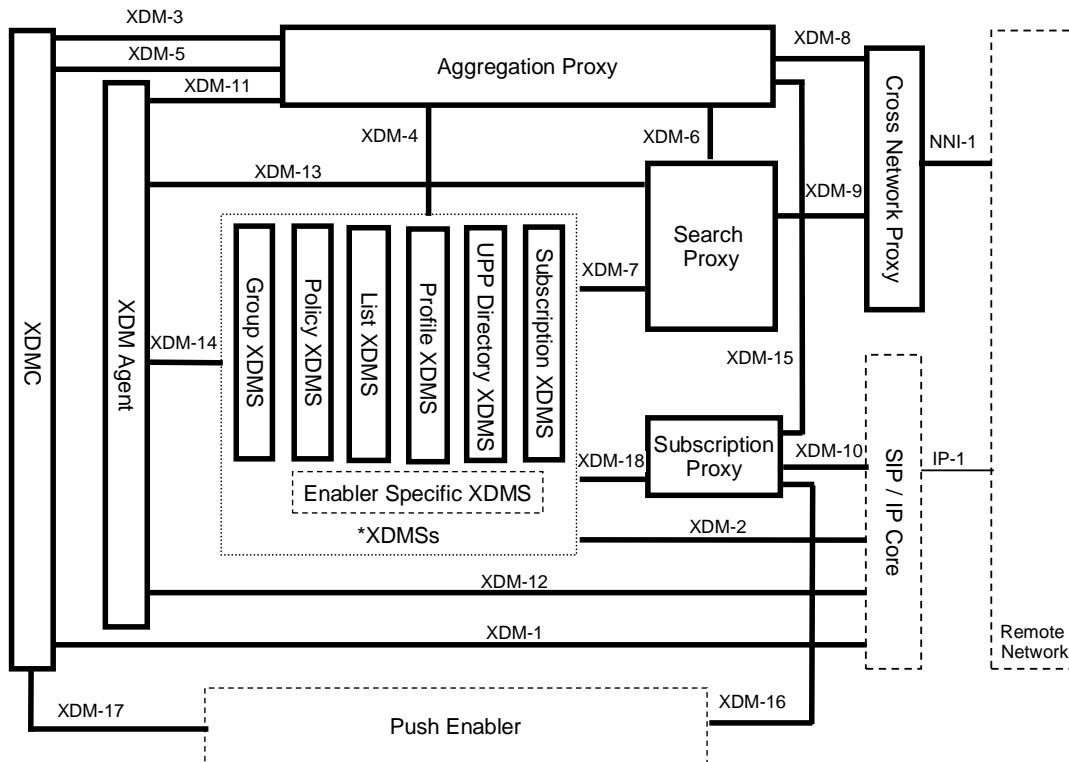

Dashed Boxes are not specified by the XDM enabler.
 *XDMSs is a logical entity to map XDMSs together for simplification

Figure 1: XDM Architecture using Reference Points

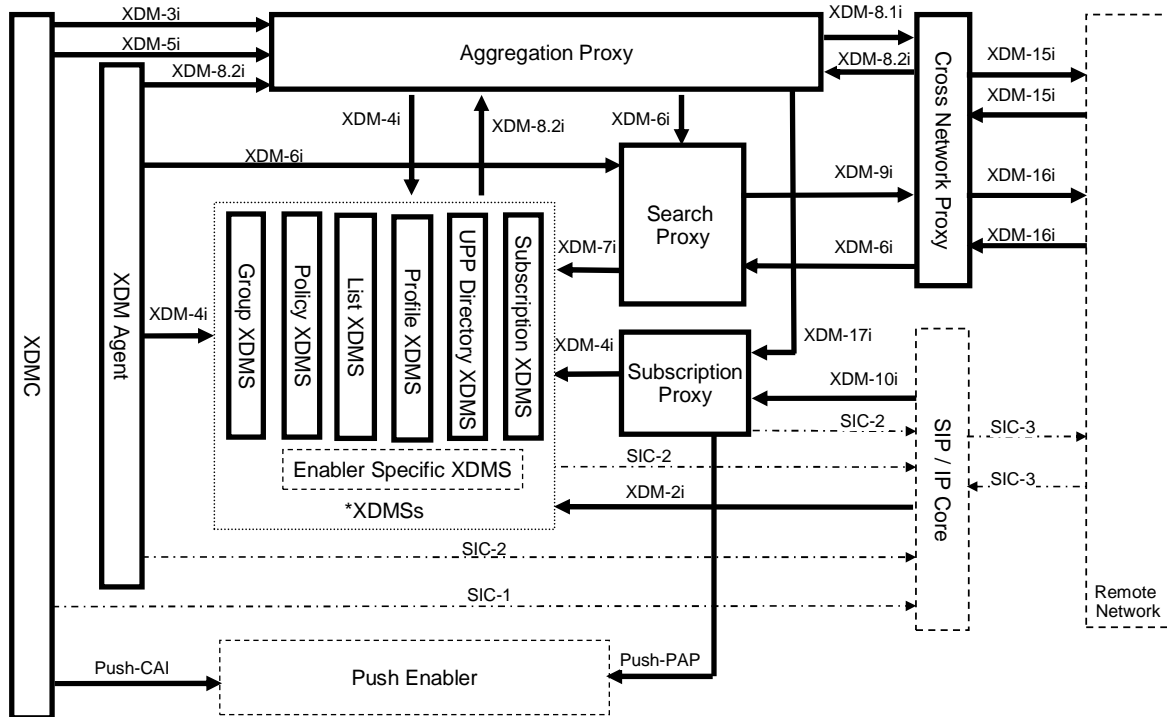

Chain dashed line are used for I2 Interfaces reused by the XDM Enabler
 Dashed Boxes are not specified by the XDM Enabler
 *XDMs is a logical entity to map XDMs together for simplification

Figure 2: XDM Architecture using Interfaces

5.3 Functional Components and Interfaces/Reference Points definition

5.3.1 XDM Functional Entities

5.3.1.1 XDMC

The XDMC is a Client used by a Principal to access various XDMS functions described in Section 5.3.1.6 "XDMSs". An XDMC implementation may provide access to various subsets of those XDMS functions, as required, subject to mandatory requirements. An XDMC may also act as a Push-Enabled Application as specified in [Push_AD-V2_2]. The XDMC may be implemented in both terminal and server entities. The XDMC uses XDM Interfaces that require authentication. The XDMC is typically deployed outside of Trusted Networks

5.3.1.2 Aggregation Proxy

The Aggregation Proxy is the single contact point for XDMCs to access XDM Resources stored in any XDMS. The Aggregation Proxy performs the following functions:

- Performs authentication of the XDMC. Alternatively, authentication can be enforced by other entities (e.g. according to [SEC_CF-V1_0]);

- Receives and routes individual XCAP requests to the correct XDMS or to the Cross-Network Proxy;
- Receives and routes individual search requests to the Search Proxy;
- Receives and routes individual XDCP requests to appropriate XDM entity;
- Optionally performs compression/decompression according to the Service Provider's local policy;
- Optionally supports secure data transfer between the Aggregation Proxy and the XDMS, (e.g. TLS) according to the Service Provider's local policy.

5.3.1.3 Subscription Proxy

The Subscription Proxy is the contact point for the XDMS to subscribe for notification of changes in XDM Resources stored in any XDMS. The Subscription Proxy supports the following functions:

- Receives subscriptions for notification of changes in XDM Resources stored in any XDMS;
- Performs back-end subscriptions for notification of changes in XDM Resources in a particular XDMS;
- Maps XDM Resources to SIP addresses of appropriate XDMSs;
- Receives notifications from XDMS, and aggregates them prior to sending them to the XDMS;
- Sends aggregated notifications to the XDMS.

5.3.1.4 Search Proxy

The Search Proxy is a server entity that performs the following functions:

- Receives search requests;
- Forwards search requests to a single or multiple instances of the XDMS and/or to the Cross-Network Proxy when appropriate;
- Receives search responses from a single or multiple instances of the XDMS and/or from the Cross-Network Proxy when appropriate;
- Combines search results from a single or multiple instances of the XDMS and/or also from the Cross-Network Proxy before sending responses to the XDMS;
- Sends search responses to the XDMS.

5.3.1.5 Cross-Network Proxy

The Cross-Network Proxy is the single contact point for XDM entities located in different networks to communicate over trusted connection. The Cross-Network Proxy performs the following functions:

- Performs authentication of the remote network. Alternatively the authentication can be enforced by the underlying transport network;
- Performs authorization of the remote network;
- Receives and routes individual outgoing XCAP requests to the Cross-Network Proxy of the remote network;
- Receives and routes individual outgoing search requests to the Cross-Network Proxy of the remote network;
- Receives and routes individual outgoing XDCP requests to the Cross-Network Proxy of the remote network;
- Receives and routes individual incoming XCAP requests to the Aggregation Proxy;

- Receives and routes individual incoming search requests to the Search proxy;
- Receives and routes individual incoming XDCP requests to the Aggregation Proxy;
- Optionally performs compression/decompression according to the Service Provider's local policy;
- Optionally support secure data transfer between Cross-Network Proxies using (e.g. TLS) according to the Service Provider's local policy.

5.3.1.6 XDMSSs

XDMS is a server entity which manages XDM Documents. The XDM Enabler defines five kinds of predefined XDMSs: List XDMS, Group XDMS, Profile XDMS, Policy XDMS and UPP Directory XDMS. Other OMA enablers may define Enabler Specific XDMSs.

Different kinds of XDMSs manage different kinds of XDM Documents. Application Usages supported by the specific XDMS define what kinds of XDM Documents it manages.

XDMSs may support all or some of the following common functionality:

5.3.1.6.1 Document Management

In order to support document management an XDMS provides the following functionality:

- Provides storage for the content of XDM Documents and other data structures used for document management (e.g. directory structure required by Application Usages, Access Permissions Documents, etc.);
- Performs authorisation of XDCP and XCAP requests.

5.3.1.6.2 Subscription and Notification of XDM Resource Changes

In order to support subscriptions and notifications of changes an XDMS provides the following functionality:

- Performs authorisation of incoming subscriptions to XDM Resource changes;
- Notifies subscribers of changes in XDM Resources;
- Provides aggregation of notifications of changes to multiple XDM Resources.

5.3.1.6.3 Access Permissions

In order to support Access Permissions an XDMS provides the following functionality:

- Manages and supports content of Access Permissions XDM Resources associated with managed XDM Resources;
- Enforces Access Permissions for the managed XDM Resources and ensures the validity of the resulting subsets of XDM Documents and consistency of XML node addressing between those subsets and original XDM Documents;
- Updates authorised Principals' Access Permissions List documents in case of a change in Access Permissions for Primary Principal's XDM Documents.

5.3.1.6.4 Search

In order to support searching of XDM Documents an XDMS provides the following functionality:

- Receives search requests;
- Provides search results.

5.3.1.6.5 History and Restore

In order to support history and restore features an XDMS provides the following functionality:

- Records operations and the information about the operations performed on managed XDM Documents based on the preferences set by the user;
- Restores managed XDM Documents back to one of their previous versions.

5.3.1.6.6 Share by Reference

In order to support sharing of XDM Resources by reference an XDMS provides the following functionality:

- Receives share by reference requests;
- Shares by reference the requested XDM Resources it manages.

5.3.1.6.7 Forwarding

In order to support forwarding of XDM Resources an XDMS provides the following functionality:

- Receives forwarding requests;
- Forwards the requested XDM Resources to specified recipients.

5.3.1.7 List XDMS

The List XDMS manages and supports the following kinds of XDM Documents:

- URI List;
- Group Usage List;
- Access Permission List;
- Forward List;
- Alias Principal List.

The List XDMS supports the following functions:

- Document Management as described in 5.3.1.6.1;
- Subscription and Notification of XDM Resource Changes as described in 5.3.1.6.2;
- Access Permissions as described in 5.3.1.6.3;
- History and Restore as described in 5.3.1.6.5;
- Share by Reference as described in 5.3.1.6.6;
- Forwarding as described in 5.3.1.6.7.

5.3.1.8 Group XDMS

The Group XDMS manages and supports the following kinds of XDM Documents:

- Group XDM Documents.

The Group XDMS supports the following functions:

- Document Management as described in 5.3.1.6.1;
- Subscription and Notification of XDM Resource Changes as described in 5.3.1.6.2;
- Access Permissions as described in 5.3.1.6.3;
- Search as described in 5.3.1.6.4;
- History and Restore as described in 5.3.1.6.5;
- Share by Reference as described in 5.3.1.6.6;
- Forwarding as described in 5.3.1.6.7;
- Supports Extended Group Advertisements.

5.3.1.9 Profile XDMS

The Profile XDMS manages and supports the following kinds of XDM Documents:

- User Profile XDM Documents.

The Profile XDMS supports the following functions:

- Document Management as described in 5.3.1.6.1;
- Subscription and Notification of XDM Resource Changes as described in 5.3.1.6.2;
- Access Permissions as described in 5.3.1.6.3;
- Search as described in 5.3.1.6.4;
- History and Restore as described in 5.3.1.6.5;
- Share by Reference as described in 5.3.1.6.6;
- Forwarding as described in 5.3.1.6.7.

5.3.1.10 Policy XDMS

The Policy XDMS manages and supports the following XDM Documents:

- User Access Policy XDM Documents.

The Policy XDMS supports the following functions:

- Document Management as described in 5.3.1.6.1
- Subscription and Notification of XDM Resource Changes as described in 5.3.1.6.2;

- Access Permissions as described in 5.3.1.6.3;
- History and Restore as described in 5.3.1.6.5;
- Share by Reference as described in 5.3.1.6.6;
- Forwarding as described in 5.3.1.6.7.

5.3.1.11 UPP Directory XDMS

The UPP Directory XDMS manages and supports the following XDM Documents:

- UPP Directory XDM Documents.

The UPP XDMS supports the following functions:

- Document Management as described in 5.3.1.6.1;
- Subscription and Notification of XDM Resource Changes as described in 5.3.1.6.2;
- Access Permissions as described in 5.3.1.6.3;
- History and Restore as described in 5.3.1.6.5;
- Share by Reference as described in 5.3.1.6.6.

5.3.1.12 Enabler Specific XDMS

The Enabler specific XDMSs manages and support XDM Resources specific to the service enabler. The enabler specific XDMS may support parts or all of the following functions:

- Document Management as described in 5.3.1.6.1;
- Subscription and Notification of XDM Resource Changes as described in 5.3.1.6.2;
- Access Permissions as described in 5.3.1.6.3;
- Search as described in 5.3.1.6.4;
- History and Restore as described in 5.3.1.6.5;
- Share by Reference as described in 5.3.1.6.6;
- Forwarding as described in 5.3.1.6.7;
- Enabler specific XDMS functions.

5.3.1.13 Subscription XDMS

The Subscription XDMS manages and supports the following XDM Documents:

- XDM Resource Subscription List.

The Subscription XDMS supports the following functions:

- Document Management as described in 5.3.1.6.1;
- Subscription and Notification of XDM Resource Changes as described in 5.3.1.6.2.

5.3.1.14 XDM Agent

The XDM Agent is an XDM entity acting on behalf of Application Server Users as a Client within the Trusted Networks. The XDM Agent uses XDM Interfaces that do not require authentication. An XDM Agent implementation may provide access to various XDMS functions described in Section 5.3.1.6 "XDMSs".

5.3.2 External Functional Entities Providing Services to XDM

5.3.2.1 SIP/IP Core

The SIP/IP Core is a network of servers, such as proxies and/or registrars, which perform a variety of services in support of the XDM Service, such as routing, authentication, compression, etc. The specific features offered by different types of SIP/IP Core networks will depend on the particulars of those networks.

When the SIP/IP Core is realized using IMS, the OMA XDMSs utilizes the capabilities of IMS as specified in 3GPP [3GPP-TS_23.228] and 3GPP2 [3GPP2-X.S0013-002], respectively. In such cases the SIP/IP Core performs the following additional functions in support of the XDM Service:

- Routes the SIP signalling between the XDMC, Subscription Proxy and the XDMSs;
- Provides discovery and address resolution services;
- Supports SIP compression;
- Performs a certain type of authorization of the XDMC based on user's service profile;
- Maintains the registration state;
- Provides charging information.

5.3.2.2 Void

The section is replaced by Appendix "*XDM Service Provisioning*".

5.3.2.3 Push Enabler

The Push Enabler Performs the following functions:

- Sends Push Messages from a Push Initiator to a Push Enabled Application as specified in [Push_AD-V2_2].

5.3.3 Description of XDM Reference Points

5.3.3.1 Reference Point XDM-1: XDMC – SIP/IP Core

The XDM-1 Reference Point supports the communication between the XDMC and the SIP/IP Core network. The protocol for the XDM-1 Reference Point is SIP.

The XDM-1 Reference Point provides the following functions:

- Subscription to the modification of any XDM Resources;
- Notification of the modification of any XDM Resources.

When SIP/IP Core corresponds with 3GPP/3GPP2 IMS, then the XDM-1 Reference Point conforms to the Gm Reference Point for XDMCs implemented in a terminal entity as specified in [3GPP-TS_23.002] [3GPP2-X.S0013-000].

The XDM-1 Reference Point consists of the SIC-1 Interface.

5.3.3.2 Reference Point XDM-2: XDMSs – SIP/IP-Core

The XDM-2 Reference Point supports the communication between the XDMSs (i.e. Profile XDMS, Group XDMS, Policy XDMS, List XDMS, UPP directory XDMS and Enabler Specific XDMSs) and the SIP/IP Core. The protocol for the XDM-2 Reference Point is SIP.

The XDM-2 Reference Point provides the following functions:

- Subscription to the modification of XDM Resources handled by a particular XDMS;
 - Notification of the modification of XDM Resources handled by a particular XDMS;
- Note: An XDMS can also subscribe to changes of XDM Resources.
- Sending of Extended Group Advertisements messages in case the XDMS is a Group XDMS.

When SIP/IP Core corresponds with 3GPP/3GPP2 IMS, then the XDM-2 Reference Point conforms to the ISC Reference Point [3GPP-TS_23.002] [3GPP2-X.S0013-000].

The XDM-2 Reference Point consists of the XDM-2i and the SIC-2 Interfaces.

5.3.3.3 Reference Point XDM-3: XDMC – Aggregation Proxy

The XDM-3 Reference Point is between the XDMC and the Aggregation Proxy. The protocols for the XDM-3 Reference Point are XCAP and XDCP.

The XDM-3 Reference Point provides the following functions:

- Management of XDM Resources (e.g. create, modify, retrieve, delete, restore) handled by any XDMS;
- History Information management for XDM documents (e.g. retrieve the History Information related to an XDM Document);
- Forwarding of XDM Resources handled by any XDMS;
- Access Permissions management for XDM Documents handled by any XDMS;
- History function related preferences management (e.g. enable/disable History function) for XDM Documents handled by any XDMS;
- Mutual authentication between XDMC and Aggregation Proxy;
- Optional compression according to the Service Provider's local policy.

When the SIP/IP Core network corresponds with 3GPP/3GPP2 IMS, then the XDM-3 Reference Point conforms to the Ut Reference Point [3GPP-TS_23.002] [3GPP2-X.S0013-000].

The XDM-3 Reference Point consists of the XDM-3i Interface.

5.3.3.4 Reference Point XDM-4: Aggregation Proxy – XDMSs

The XDM-4 Reference Point is between the Aggregation Proxy and the XDMSs. The protocols for the XDM-4 Reference Point are XCAP and XDCP.

The XDM-4 Reference Point provides the following functions:

- Management of XDM Resources (e.g. create, modify, retrieve, delete, restore) handled by a particular XDMS;
- History Information management for XDM Documents (e.g. retrieve the History information related to an XDM Document);
- Forwarding of XDM Resources handled by a particular XDMS;
- Access Permissions management for XDM Documents handled by a particular XDMS;
- History function related preferences management (e.g. enable/disable History function) for XDM Documents handled by particular XDMS;
- Management (e.g. create, modify, retrieve, delete, restore) of XDM Resources requested by an XDMS but handled by any other XDMS.

The XDM-4 Reference Point consists of the XDM-4i and the XDM-8.2i Interfaces.

5.3.3.5 Reference Point XDM-5: XDMC – Aggregation Proxy

The XDM-5 Reference Point is between the XDMC and the Aggregation Proxy. The protocol for the XDM-5 Reference Point is Limited XQuery over HTTP [XDM_Core].

The XDM-5 Reference Point provides the following functions:

- Searching information from XDM Documents stored in any XDMS;
- Searching information from History Information XDM Documents stored in any XDMS;
- Optional mutual authentication of search requests between XDMC and Aggregation Proxy;
- Optional compression according to the Service Provider's local policy.

When the SIP/IP Core network corresponds with 3GPP/3GPP2 IMS, then the XDM-5 Reference Point conforms to the Ut Reference Point [3GPP-TS_23.002] [3GPP2-X.S0013-000].

The XDM-5 Reference Point consists of the XDM-5i Interface.

5.3.3.6 Reference Point XDM-6: Aggregation Proxy – Search Proxy

The XDM-6 Reference Point is between the Aggregation Proxy and the Search Proxy. The protocol for the XDM-6 Reference Point is Limited XQuery over HTTP.

The XDM-6 Reference Point provides the following functions:

- Searching information from XDM Documents stored in any XDMS;
- Searching information from History Information XDM Documents stored in any XDMS.

The XDM-6 Reference Point consists of the XDM-6i Interface.

5.3.3.7 Reference Point XDM-7: Search Proxy – XDMSs

The XDM-7 Reference Point is between the Search Proxy and the XDMSs. The protocol for the XDM-7 Reference Point is Limited XQuery over HTTP.

The XDM-7 Reference Point provides the following functions:

- Searching information from XDM Documents stored in an XDMS supporting search;
- Searching data from History Information stored in an XDMS supporting search of History Information.

The XDM-7 Reference Point consists of the XDM-7i Interface.

5.3.3.8 Reference Point XDM-8: Aggregation Proxy – Cross-Network Proxy

The XDM-8 Reference Point is between the Aggregation Proxy and the Cross-Network Proxy. The protocols for the XDM-8 Reference Point are XCAP and XDCP.

The XDM-8 Reference Point provides the following functions:

- Forwarding of XDM Resource management requests/responses between the Aggregation Proxy and the Cross-Network Proxy.

The XDM-8 Reference Point consists of the XDM-8.1i and the XDM-8.2i Interfaces.

5.3.3.9 Reference Point XDM-9: Search Proxy – Cross-Network Proxy

The XDM-9 Reference Point is between the Search Proxy and the Cross-Network Proxy. The protocol for the XDM-9 Reference Point is Limited XQuery over HTTP.

The XDM-9 Reference Point provides the following functions:

- Forwarding of search requests/responses between the Search Proxy and the Cross-Network Proxy.

The XDM-9 Reference Point consists of the XDM-9i and the XDM-6i Interfaces.

5.3.3.10 Reference Point XDM-10: Subscription Proxy – SIP/IP Core

The XDM-10 Reference Point supports the communication between the Subscription Proxy and the SIP/IP Core network. The protocol for the XDM-10 Reference Point is SIP.

The XDM-10 Reference Point provides the following functions:

- Subscription to the modification of any XDM Resources;
- Notification of the modification of any XDM Resources;
- Back-end subscription to the modification of XDM Resources handled by a particular XDMS;
- Notification of the modification of XDM Resources handled by a particular XDMS.

When SIP/IP Core network corresponds with 3GPP IMS or 3GPP2 MMD networks, then the XDM-10 Reference Point conforms to the ISC Reference Point as specified in [3GPP-TS_23.002] [3GPP2-X.S0013-000].

The XDM-10 Reference Point consists of the XDM-10i and the SIC-2 Interfaces.

5.3.3.11 Reference Point XDM-11: XDM Agent - Aggregation Proxy

The XDM-11 Reference Point supports the communication between the XDM Agent and the Aggregation Proxy. The protocol for the XDM-11 Reference Point is XCAP and XDCP.

The XDM-11 Reference Point provides the following functions:

- Management of XDM Resources (e.g. create, modify, retrieve, delete) handled by any XDMS in any network.

The XDM-11 Reference Point consists of the XDM-8.2i Interface.

5.3.3.12 Reference Point XDM-12: XDM Agent– SIP/IP Core

The XDM-12 Reference Point supports the communication between the XDM Agent and the SIP/IP Core. The protocol for the XDM-12 Reference Point is SIP.

The XDM-12 Reference Point provides the following functions:

- Subscription to the modification of XDM Resources handled by a particular XDMS;
- Notification of the modification of XDM Resources handled by a particular XDMS.

When SIP/IP Core corresponds with 3GPP/3GPP2 IMS, then the XDM-11 Reference Point conforms to the ISC Reference Point [3GPP-TS_23.002] [3GPP2-X.S0013-000].

The XDM-12 Reference Point consists of the SIC-2 Interface.

5.3.3.13 Reference Point XDM-13: XDM Agent - Search Proxy

The XDM-13 Reference Point is between the XDM Agent and the Search Proxy. The protocol for the XDM-13 Reference Point is Limited XQuery over HTTP.

The XDM-13 Reference Point provides the following functions:

- Searching information from XDM Documents stored in any XDMS.

The XDM-13 Reference Point consists of the XDM-6i Interface.

5.3.3.14 Reference Point XDM-14: XDM Agent – XDMSs

The XDM-14 Reference Point is between the XDM Agent and the XDMSs. The protocol for the XDM-14 Reference Point is XCAP and XDCP.

The XDM-14 Reference Point provides the following functions:

- Management of XDM Resources (e.g. create, modify, retrieve, delete) handled by a particular XDMS residing in the same network as the XDM Agent;
- Forwarding of XDM Resources handled by a particular XDMS residing in the same network as the XDM Agent.

The XDM-14 Reference Point consists of the XDM-4i Interface.

5.3.3.15 Reference Point XDM-15: Aggregation Proxy – Subscription Proxy

The XDM-15 Reference Point is between the Aggregation Proxy and the Subscription Proxy. The protocol for the XDM-15 Reference Point is XDCP.

The XDM-15 Reference Point provides the following functions:

- Subscription for Push Messages of XDM Resource changes.

The XDM-15 Reference Point consists of the XDM-17i Interface.

5.3.3.16 Reference Point XDM-16: Subscription Proxy – Push Enabler

The XDM-16 Reference Point is between the Subscription Proxy and the Push Enabler.

The XDM-16 Reference Point provides the following functions:

- Sending Push Messages to XDMCs.

The XDM-16 Reference Point consists of the Push-PAP Interface [Push_AD-V2_2]

5.3.3.17 Reference Point XDM-17: XDMC – Push Enabler

The XDM-17 Reference Point is between the XDMC and the Push Enabler.

The XDM-17 Reference Point provides the following functions:

- Reception of XDM Resource related push messages.

The XDM-17 Reference Point consists of the Push-CAI Interface [Push_AD-V2_2]

5.3.3.18 Reference Point XDM-18: Subscription Proxy – XDMSs

The XDM-18 Reference Point is between the Subscription Proxy and the XDMSs. The protocol for the XDM-18 Reference Point is XCAP.

The XDM-18 Reference Point provides the following functions:

- Manipulation of XDM Resource Subscription List from the Subscription XDMS.

The XDM-18 Reference Point consists of the XDM-4i Interface.

5.3.3.19 Reference Point NNI-1: Cross-Network Proxy – Cross-Network Proxy of remote network

The NNI-1 Reference Point supports the communication between XDM entities in different domains connected via Cross-Network Proxies. The protocols for the NNI-1 Reference Point are XCAP, XDCP and Limited XQuery over HTTP transported optionally using any secure protocol or connection (e.g. TLS) according to the Service Provider's local policy.

5.3.4 External Reference Points Providing Services to XDM

5.3.4.1 Reference Point IP-1: SIP/IP Core – SIP/IP Core of remote network

The IP-1 Reference Point supports the communication between the SIP/IP Core network and an XDMS in the remote network via the SIP/IP Core of the remote network. The protocol for the IP-1 Reference Point is SIP.

When the SIP/IP Core network corresponds with 3GPP IMS or 3GPP2 MMD networks, then the IP-1 Reference Point conforms to the Ici Reference Point as specified in [3GPP-TS_23.002] [3GPP2-X.S0013-000].

The IP-1 Reference Point consists of the SIC-3 Interface.

5.4 Description of Interfaces

5.4.1 XDM Interfaces

5.4.1.1 Interface XDM-2i: XDMSs

The XDM-2i Interface is exposed by the XDMSs. The protocol for the XDM-2i Interface is SIP.

The XDM-2i Interface provides the following functions:

- Subscription to the modification of XDM Resources handled by a particular XDMS;
- Notification of the modification of XDM Resources handled by a particular XDMS.

5.4.1.2 Interface XDM-3i: Aggregation Proxy

The XDM-3i Interface is exposed by the Aggregation Proxy. The protocols for the XDM-3i Interface are XCAP and XDCP.

The XDM-3i Interface provides the following functions:

- Management of XDM Resources (e.g. create, modify, retrieve, delete, restore) handled by any XDMS;
- History Information management for XDM Documents (e.g. retrieve the History Information related to an XDMDocument);
- Forwarding of XDM Resources handled by any XDMS;

- Access Permissions management for XDM Documents handled by any XDMS;
- History function related preferences management (e.g. enable/disable History function) for XDM Documents handled by any XDMS;
- Optional mutual authentication between XDMS and Aggregation Proxy;
- Optional compression according to the Service Provider's local policy.

5.4.1.3 Interface XDM-4i: XDMSs

The XDM-4i Interface is exposed by the XDMSs. The protocols for the XDM-4i Interface are XCAP and XDCCP.

The XDM-4i Interface provides the following functions:

- Management of XDM Resources (e.g. create, modify, retrieve, delete, restore) handled by a particular XDMS;
- History Information management for XDM Documents (e.g. retrieve the History information related to an XDM Document);
- Forwarding of XDM Resources handled by a particular XDMS;
- Access Permissions management for XDM Documents handled by a particular XDMS;
- History function related preferences management (e.g. enable/disable History function) for XDM Documents handled by a particular XDMS.

5.4.1.4 Interface XDM-5i: Aggregation Proxy

The XDM-5i Interface is exposed by the Aggregation Proxy. The protocol for the XDM-5i Interface is Limited XQuery over HTTP.

The XDM-5 Interface provides the following functions:

- Searching information from XDM Documents stored in any XDMS;
- Searching information from History Information XDM Documents stored in any XDMS;
- Optional mutual authentication of search requests between XDMS and Aggregation Proxy;
- Optional compression according to the Service Provider's local policy.

5.4.1.5 Interface XDM-6i: Search Proxy

The XDM-6i Interface is exposed by the Search Proxy. The protocol for the XDM-6i Interface is Limited XQuery over HTTP.

The XDM-6 Interface provides the following functions:

- Searching information from XDM Documents stored in any XDMS;
- Searching information from History Information XDM Documents stored in any XDMS.

5.4.1.6 Interface XDM-7i: XDMSs

The XDM-7i Interfaces is exposed by the XDMSs. The protocol for the XDM-7i Interface is Limited XQuery over HTTP.

The XDM-7i Interface provides the following functions:

- Searching information from XDM Documents stored in an XDMS supporting search;

- Searching data from History Information stored in an XDMS supporting search of History Information.

5.4.1.7 Interface XDM-8.1i: Cross-Network Proxy

The XDM-8.1i Interface is exposed by the Cross-Network Proxy. The protocols for the XDM-8.1i Interface are XCAP and XDCP.

The XDM-8.1i Interface provides the following functions:

- Routing and forwarding of requests to the Cross-Network Proxy for management of XDM Resources (e.g. create, modify, retrieve, delete, forward) handled by any XDMS in remote networks;
- Receiving responses from the Cross-Network Proxy for management of XDM Resources (e.g. create, modify, retrieve, delete, forward) handled by any XDMS in remote networks.

5.4.1.8 Interface XDM-8.2i: Aggregation Proxy

The XDM-8.2i Interface is exposed by the Aggregation Proxy. The protocol for the XDM-8.2i Interface is XCAP and XDCP.

The XDM-8.2i Interface provides the following functions:

- Forwarding of requests to the Aggregation Proxy for management of XDM Resources (e.g. create, modify, retrieve, delete, forward) handled by any XDMS;
- Receiving responses from the Aggregation Proxy for management of XDM Resources (e.g. create, modify, retrieve, delete, forward) handled by any XDMS.

5.4.1.9 Interface XDM-9i: Cross-Network Proxy

The XDM-9i Interface is exposed by the Cross-Network Proxy. The protocol for the XDM-9i Interface is Limited XQuery over HTTP.

The XDM-9i Interface provides the following functions:

- Routing and forwarding of search requests to the Cross-Network Proxy for searches in remote domains;
- Receiving search responses from the Cross-Network Proxy for searches in remote domains.

5.4.1.10 Interface XDM-10i: Subscription Proxy

The XDM-10i Interface is exposed by the Subscription Proxy. The protocol for the XDM-10i Interface is SIP.

The XDM-10i Interface provides the following functions:

- Subscription to modifications of any XDM Resources;
- Notification of modifications of any XDM Resources.

5.4.1.11 Interface XDM-15i: Cross-Network Proxy

The XDM-15i Interface is exposed by the Cross-Network Proxy. The protocols for the XDM-15i Interface is XCAP and XDCP transported using any secure protocol or connection e.g. TLS between remote networks.

The XDM-15i Interface provides the following functions:

- Forwarding of requests to the Cross-Network Proxy for management of XDM Resources (e.g. create, modify, retrieve, delete) handled by any XDMS residing in the same domain as the Cross-Network Proxy;

- Receiving responses from the Cross-Network Proxies for management of XDM Resources (e.g. create, modify, retrieve, delete) handled by any XDMS residing in the same domain as the Cross-Network Proxy.

5.4.1.12 Interface XDM-16i: Cross-Network Proxy

The XDM-16i Interface is exposed by the Cross-Network Proxy. The protocol for the XDM-16i Interface is Limited XQuery over HTTP transported using any secure protocol or connection e.g. TLS between remote networks.

The XDM-16i Interface provides the following functions:

- Forwarding of search requests to the Cross-Network Proxy for searching information from XDM Documents stored in any XDMS residing in the same domain as the Cross-Network Proxy;
- Receiving search responses from the Cross-Network Proxy for the search requests.

5.4.1.13 Interface XDM-17i: Subscription Proxy

The XDM-17i Interface is exposed by the Subscription Proxy. The protocol for the XDM-17i Interface is XDCP.

The XDM-17i Interface provides the following function:

- Subscription for Push Messages of XDM Resource changes.

5.4.2 External Interfaces used by the XDM Enabler

5.4.2.1 Interface SIC-1: SIP/IP Core

The SIC-1 Interface is exposed by the SIP/IP Core network and reused by the XDM Enabler. The protocol for the SIC-1 Interface is SIP.

The SIC-1 Interface provides the following functions:

- Authentication;
- Subscription to the modification of any XDM Resources;
- Notification of the modification of any XDM Resources.

When the SIP/IP Core network corresponds with 3GPP IMS or 3GPP2 MMD networks, then the SIC-1 Interface conforms to the interface that the Gm Reference Point is accessed through as specified in [3GPP-TS_23.002] [3GPP2-X.S0013-000].

5.4.2.2 Interface SIC-2: SIP/IP Core

The SIC-2 Interface is exposed by the SIP/IP Core network and reused by the XDM Enabler. The protocol for the SIC-2 Interface is SIP.

The SIC-2 Interface provides the following functions:

- Subscription to the modification of any XDM Resources;
- Notification of the modification of any XDM Resources;
- Sending of Extended Group Advertisements messages in case the XDMS is a Group XDMS.

When the SIP/IP Core network corresponds with 3GPP IMS or 3GPP2 MMD networks, then the SIC-2 Interface conforms to the interface that the ISC Reference Point is accessed through as specified in [3GPP-TS_23.002] [3GPP2-X.S0013-000].

5.4.2.3 Interface SIC-3: SIP/IP Core

The SIC-3 Interface is exposed by the SIP/IP Core and reused by the XDM Enabler. The protocol for the SIC-3 Interface is SIP.

- The SIC-3i Interface supports the communication between SIP/IP Core networks.

When the SIP/IP Core network corresponds with 3GPP IMS or 3GPP2 MMD networks, then the SIC-3 Interface conforms to the interface that the Ici Reference Point is accessed through as specified in [3GPP-TS_23.002] [3GPP2-X.S0013-000].

5.4.2.4 Interface Push-PAP: Push Enabler

This interface is described in [Push_AD-V2_2]

5.4.2.5 Interface Push-CAI: Push Enabler

This interface is described in [Push_AD-V2_2]

5.5 Security Considerations

The XDM Agent is authorized in the XDMS based on the received identity information;

For an XDMS, the necessary integrity and confidentiality protection (e.g. TLS) and authentication (e.g. HTTP Digest [RFC4825], GAA [3GPP-TS_33.222]) are enforced according to Service Provider's local policy.

6. Backward Compatibility

6.1 Backward Compatibility towards the XDM 2.0 version

The following deployment scenarios are supported for the purpose of backward compatibility for the XDM Enabler version 2.1 described in this document:

Scenario A) whereby:

- XDM Enabler version 2.0 [XDM_ERELD-V2_0] server entity implementations are replaced with XDM Enabler version 2.1 server entity implementations; and
- XDM Enabler version 2.0 [XDM_ERELD-V2_0] XDMC implementations exist e.g. embedded in other Enablers entities.

In order to support Scenario A) it is required that:

- All XDM Enabler version 2.1 XDM entities supports all XDM Enabler version 2.0 functions including the backward compatibility scenarios described in section 6.2:

Scenario B) whereby:

- XDM Enabler version 2.0 [XDM_ERELD-V2_0] server entity implementations are not replaced with XDM Enabler version 2.1 [XDM_ERELD-V2_1] server entity implementations; and
- XDM Enabler version 2.1 [XDM_ERELD-V2_1] XDMC implementations are introduced e.g. via other Enablers.

In order to support Scenario B) it is required that:

- XDM Enabler version 2.1 XDMC implementations use the XDM Enabler defined capability requests to find out with type of XDM Documents that are supported in order to use only XDM Enabler version 2.0 specified XDM Documents.

NOTE: The XDM Enabler version 2.0 entities “Shared Group XDMS”, “Shared List XDMS”, “Shared Policy XDMS” and “Shared Profile XDMS” have in the XDM Enabler version 2.1 been renamed to “Group XDMS”, “List XDMS”, “Policy XDMS” and “Profile XDMS” but this does not affect the implementation of any other entity implemented according to the XDM Enabler versions 2.0 or 2.1 specifications.

6.2 Backward compatibility towards the XDM Enabler version 1.1 and the PoC Enabler version 1.0.

The following deployment scenarios are supported for the purpose of backward compatibility for the XDM Enabler version 2.0 [XDM_ERELD-V2_0]:

Scenario A) whereby:

- The XDM Enabler version 1.1 [XDM_ERELD-V1_1] is replaced with the XDM Enabler version 2.0 [XDM_ERELD-V2_0]. The PoC Enabler version 1.0 [PoC_ERELD-V1_0] is replaced with the PoC Enabler version 2.0 [PoC_ERELD-V2_0]. The PoC Enabler version 2.0 and later shares Group and User Access Policy XDM Documents in Shared Group XDMS and Shared Policy XDMS, with other Enablers (e.g., SIMPLE IM Enabler version 1.0 [IM_ERELD-V1_0]);
- The XDM version 1.1 clients implemented in a PoC version 1.0 compliant UE are supported for the purpose of backward compatibility;

- The XDM version 1.1 clients implemented in a PoC version 1.0 compliant PoC Application Server are not supported, as the PoC Enabler is upgraded to version 2.0;
- The XDM version 2.0 clients implemented in a PoC version 2.0 compliant UE are supported;
- The XDM version 2.0 clients implemented in a PoC version 2.0 compliant PoC Application Server are supported.

In order to support Scenario A) it is required that:

- The Aggregation Proxy supports also via the Reference Point XDM-4 the Reference Point PoC-7 [PoC_AD-V1_0] to route the PoC group or PoC User Access Policy XDM Document requests to Shared Group XDMS or Shared Policy XDMS respectively;
- The Shared Group XDMS supports also via the Reference Point XDM-2 the Reference Point PoC-6 [PoC_AD-V1_0] to process the PoC group XDM Documents SIP requests and to generate corresponding responses and to generate SIP requests and to process corresponding responses as if it is PoC XDMS [PoC_AD-V1_0];
- The Shared Group XDMS supports also via the Reference Point XDM-4 the Reference Point PoC-7 [PoC_AD-V1_0] to process the PoC group XDM Documents requests and to generate corresponding responses as if it is PoC XDMS [PoC_AD-V1_0];
- The Shared Policy XDMS supports also via the Reference Point XDM-2 the Reference Point PoC-6 [PoC_AD-V1_0] to process the PoC User Access Policy XDM Document SIP requests and to generate corresponding responses and to generate SIP requests and to process corresponding responses as if it is PoC XDMS [PoC_AD-V1_0];
- The Shared Policy XDMS supports also via the Reference Point XDM-4 the Reference Point PoC-7 [PoC_AD-V1_0] to process the PoC User Access Policy XDM Document requests and to generate corresponding responses as if it is PoC XDMS [PoC_AD-V1_0]; and
- The XDM version 1.0 clients implemented in a PoC version 1.0 compliant UE are able to make requests through the Reference Point XDM-3 to access the PoC group or PoC User Access Policy XDM Documents in Shared Group XDMS or Shared Policy XDMS, as if they reside in PoC XDMS.

Scenario B) whereby:

- The XDM Enabler version 1.1 [XDM_ERELD-V1_1] is replaced with the XDM Enabler version 2.0 [XDM_ERELD-V2_0] due to other Enablers (e.g., SIMPLE IM version 1.0 [IM_ERELD-V1_0]) than PoC Enabler version 1.0 [PoC_ERELD-V1_0]. However, the PoC Enabler version 1.0 remains as it is. The PoC Enabler version 1.0 does not share PoC group or PoC User Access Policy XDM Documents with other Enablers, but keep those in PoC XDMS [PoC_AD-V1_0];
- The XDM version 1.1 clients implemented in a PoC version 1.0 compliant UE are supported for the purpose of backward compatibility;
- XDM version 1.1 clients implemented in a PoC version 1.0 compliant PoC Application Server are supported for the purpose of backward compatibility;
- The XDM version 2.0 clients implemented in a PoC version 2.0 compliant UE are supported;
- XDM version 2.0 clients implemented in a PoC version 2.0 compliant PoC Application Server are not supported as the PoC Enabler remain as version 1.0.

In order to support Scenario B) it is required that:

- The Aggregation Proxy supports also via the Reference Point XDM-4 the Reference Point PoC-7 [PoC_AD-V1_0] to route the PoC group or PoC User Access Policy XDM Documents requests to PoC XDMS; and

- The XDM version 2.0 clients implemented in a PoC version 2.0 compliant UE are able to use their embedded PoC version 1.0 functions to make requests through the Reference Point XDM-3 to access the PoC group or PoC User Access Policy XDM Documents in PoC XDMS.

Appendix A. Change History

(Informative)

A.1 Approved Version History

Reference	Date	Description
n/a	n/a	No prior version

A.2 Draft/Candidate Version 2.1 History

Document Identifier	Date	Sections	Description
Draft Versions: OMA-AD-XDM-V2_1	22 Oct 2008	N/A	First version for XDM 2.1 made using OMA-AD-XDM-V2_0-20080916-C as a basis (OMA-PAG-2008-0697)
	27 Mar 2009	4.2, 4.3 5, 5.1 3.2, 5.3 3.2, 5.2	OMA-PAG-2009-079R02 OMA-PAG-2009-081R01 OMA-PAG-2009-085R02 OMA-PAG-2009-0086 OMA-PAG-2009-099R01
	28 Apr	5.3, 3.1, 3.2, 4.3, 5.2, 3.3	OMA-PAG-2009-088R01 OMA-PAG-2009-116R01 OMA-PAG-2009-117R03 OMA-PAG-2009-0120R01 OMA-PAG-2009-135R01
	25 May 2009	All	Incorporated CR applying 2009 template: OMA-PAG-2009-0149R02
	27 May 2009	All	OMA-PAG-2009-0157 Minor editorials
	3 Jun 2009	3.2, 3.3, 4.1, 4.2, 5.3.1.1, 5.3.1.6, 5.4.1.3,	OMA-PAG-2009-0151 OMA-PAG-2009-0164 OMA-PAG-2009-0166 OMA-PAG-2009-0167
	12 Jun 2009	All	OMA-PAG-2009-0165 Editorial correction to footers and fixing of defective numbering in the whole document
	16 Jun 2009	3.2, 5.3.1, 5.3.3, 5.4.1	OMA-PAG-2009-0176R02
	6 Aug 2009	All	OMA-PAG-2009-0218R02 (editorial ADRR comments)
	26 Aug 2009	All	OMA-PAG-2009-0239 OMA-PAG.2009-0240R01 OMA-PAG-2009-0243 OMA-PAG-2009-0244 OMA-PAG.2009-0248 OMA-PAG-2009-0250R01 OMA-PAG-2009-0251R01 OMA-PAG-2009-0254R01 OMA-PAG-2009-0257 OMA-PAG-2009-0258R01 OMA-PAG-2009-0259R01 OMA-PAG_2009-0260R01 OMA-PAG-2009-262R02 OMA-PAG-2009-0263R01 OMA-PAG-2009-0268 OMA-PAG-2009-275R01 OMA-PAG-2009-277R01 OMA-PAG-2009-281R02

Document Identifier	Date	Sections	Description
	1 Sep 2009	2.1, 2.2, 3.2, 5.1, 5.3.1.1, 5.3.1.6, 5.3.2.2, 5.3.3.7, 5.4.1.6, App C	OMA-PAG-0195R01 OMA-PAG-0255R02 OMA-PAG-0276R03 OMA-PAG-0282R01
	2 Sept	5.3.3.7, 5.4.1.6	Added missed text from OMA-PAG-2009-0255R02
	17 Sept	5.3.1.6-5.3.1.12	OMA-PAG-2009-0283R02
	21 Sept	2.1, 2.2, 5.1, 5.3.2.3, 5.4.2.4, App D	OMA-PAG-2009-0284 OMA-PAG-2009-0308R01
	22 Sept	3.2, 5.2, 5.3, 5.5, 5.3.1.7, App B, App D	OMA-PAG-2009-0119R02 OMA-PAG-2009-318R01, Applied missing part of OMA-PAG-2009-0308R01
	23 Sept	2.1, 3.2, 5.2, 5.3, 5.4, 5.5, App C	OMA-PAG-2009-0313R02 OMA-PAG-2009-0314R01 OMA-PAG-2009-0320R01 OMA-PAG-2009-0322R01 OMA-PAG-2009-0326R01
	25 Sept	5.3.3.2	OMA-PAG-2009-0314R02 (delta from R01)
Draft Version OMA-AD-XDM-V2_1	29 Sept	ToC, 5.2, 5.3, 5.4, 6.1	Fixed incorrect numbering, spelling errors
Candidate Version OMA-AD-XDM-V2_1	23 Oct 2009	N/A	Status changed to Candidate by TP TP ref # OMA-TP-2009-0454- INP_XDM_V2_1_AD_for_Candidate_approval

Appendix B. How to show re-use of the XDM Enabler (Informative)

This section describes how OMA Enabler can re-use the XDM Enabler and shows how this should be reflected in the Enabler’s architecture diagrams.

To make the architecture diagrams of Enablers re-using XDM Enabler simpler, the architecture diagrams should show only how the Enabler is using the different XDMSs and not the entire XDM architecture model. The architecture document is recommended to include the following information:

- A figure as shown below as part of the “Architectural Diagram” section. It is recommended
 - to shows which Enabler specific entities that are using the XDM Enabler;
 - to show which XDMSs that the Enabler is using;
 - to show which of XDM/SIC Interfaces Enabler specific entities are using;
 - to show an Enabler Specific Entity with an embedded XDMC when the functions of an XDMC defined in the XDM Enabler does not cover needs of the reusing Enabler;
 - not to show in the “main” Enabler architectural diagram how the XDM Enabler is used.
- In the section “Functional Entities” it is recommended that per Entity using the XDM Enabler it is listed which particular XDMSs this entity is using;
- In the section “Functional Entities” it is recommended that per Enabler Specific XDMS it is listed which XDM functions in the list in section 5.3.1.12 it supports;
- The XDM Interfaces in the diagram are recommended to be described under a Sub section “External Interfaces” under the “Interfaces” Section in the architecture document. The description is recommended only to contain a text that contains a reference to the XDM-AD e.g. “The XDM-8.2i Interface is described in [XDM_AD]”.

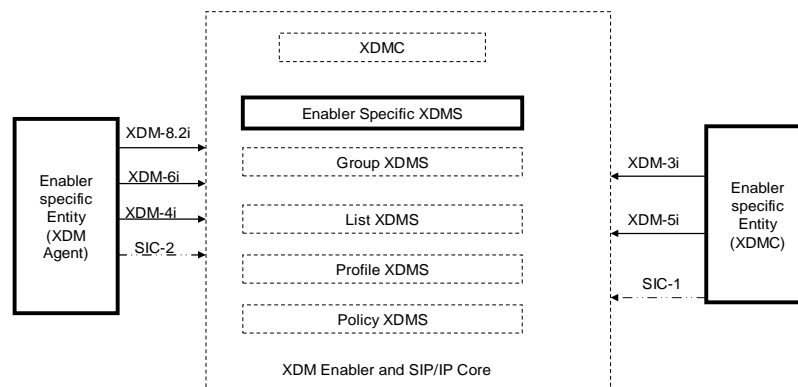

Dashed Boxes and Interfaces are described in [XDM_AD]

Figure 3: How to show reuse of the XDM Enabler.

Appendix C. XDM Service Provisioning

An XDM Service provider can set up the XDM Service configurations remotely in an XDMC in a terminal device. When DM Enabler [DM_ERELD] is deployed, Device management as specified in [DM_SO] provides the support for remote provisioning and management of an XDM Enabler specified Management Object containing necessary configuration parameters for the XDMC in the terminal device.

Appendix D. Use of Charging Enabler for XDM Charging (Informative)

The OMA Charging Enabler [Charging_AD] coordinates charging data triggers and flow from OMA Enablers into an underlying charging infrastructure, supporting on-line and off-line charging. XDM entities that may optionally report Chargeable Events are:

- Aggregation Proxy;
- Subscription Proxy;
- Search Proxy;
- XDM Enabler defined XDMSs (i.e. Profile XDMS, Group XDMS, Policy XDMS, List XDMS and UPP Directory XDMS);
- Enabler specific XDMSs.

The CH-1 and CH-2 Interfaces are described in [Charging_AD].

Implementations of XDM components may act as Charging Enabler users [Charging_AD]. Figure 4 shows the Interfaces between these entities and the charging Enabler. Two Interfaces are currently supported by the Charging Enabler, CH-1 for offline charging and CH-2 for on line charging. These are described in [Charging_AD].

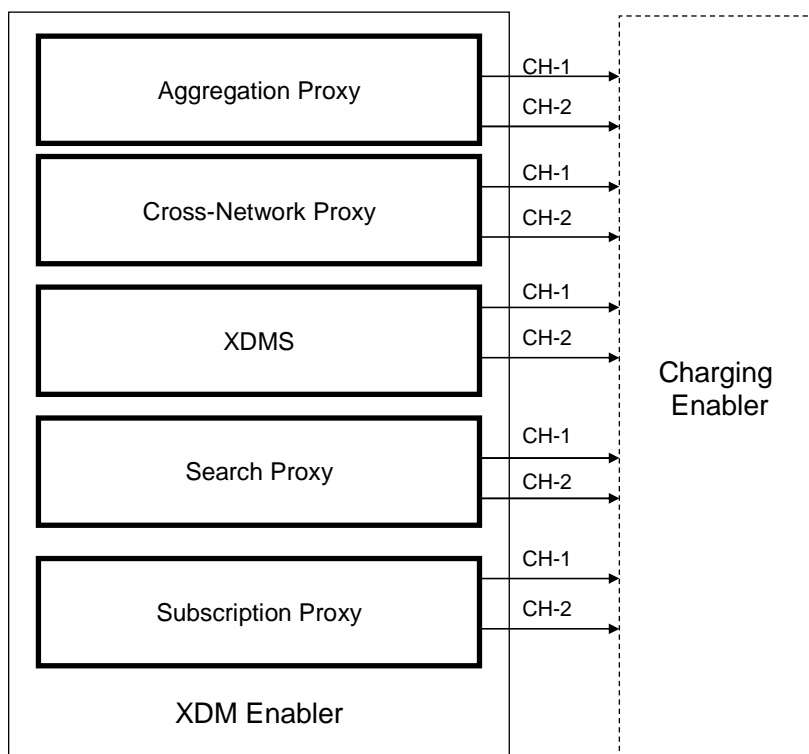

Dashed Boxes and Interfaces are not specified by XDM Enabler

Figure 4: XDM Enabler Use of the Charging Enabler’s CH-1 and CH-2 Interfaces